

BEFCO[®]

Operator's Manual

DESTROYER

Heavy Duty Flail Shredder

D90-060, D90-072, D90-088

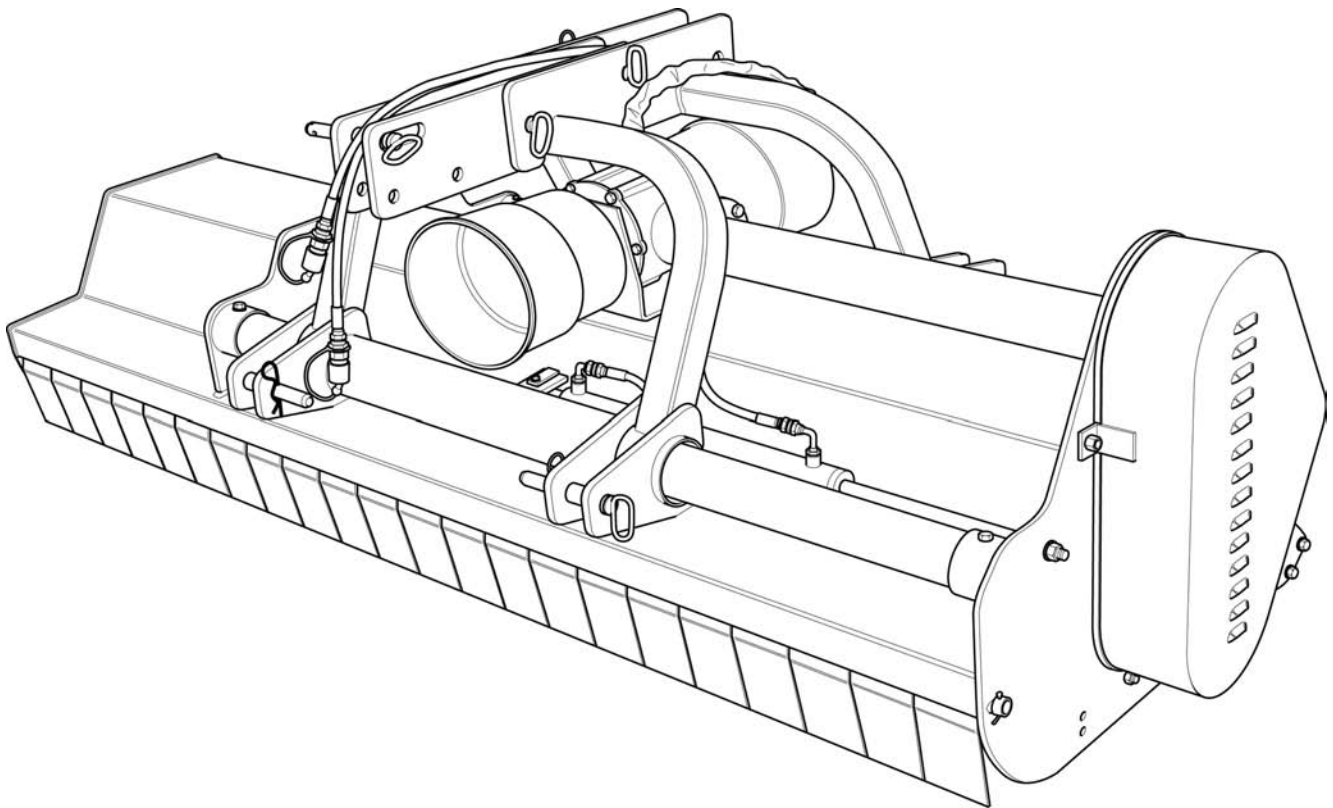

The operator's manual is a technical service guide and must always accompany the machine.

Manual 971-401B

May 2010

SAFETY

Take note! This safety alert symbol found throughout this manual is used to call your attention to instructions involving your personal safety and the safety of others. Failure to follow these instructions can result in injury or death.



*This symbol means:
ATTENTION!
BECOME ALERT!
YOUR SAFETY IS INVOLVED!*

Signal Words

Note the use of the signal words DANGER, WARNING and CAUTION with the safety messages. The appropriate signal words for each have been selected using the following guidelines:



DANGER: Indicates an imminently hazardous situation that, if not avoided, will result in death or serious injury.



WARNING: Indicates a potentially hazardous situation that, if not avoided, could result in death or serious injury, and includes hazards that are exposed when guards are removed. It may also be used to alert against unsafe practices.



CAUTION: Indicates a potentially hazardous situation that, if not avoided, may result in minor or moderate injury.

INDEX

1 - GENERAL INFORMATION	4
1.01 - General	4
1.02 - Model and Serial Number ID	5
2 - SAFETY PRECAUTIONS	6
2.01 - Preparation	6
2.02 - Starting and Stopping	7
2.03 - Messages and Signs	7
3 - OPERATION	10
3.01 - Operational Safety	10
3.02 - Set Up	12
3.03 - Cutting Height Adjustment	13
3.04 - Pre-Operational Check	14
3.05 - Attaching to the Tractor	14
3.06 - Start Up	15
3.07 - Working Speed	16
3.08 - Operating Techniques	17
3.09 - Hydraulic Side Shift	18
3.10 - Uneven Terrain	19
3.11 - Removing Shredder from the Tractor	19
3.12 - Transport	19
4 - MAINTENANCE	21
4.01 - Maintenance Safety	21
4.02 - Service	22
4.03 - Blade Maintenance	23
4.04 - Belt Tension	25
4.05 - Belt Replacement	26
4.06 - Pulley Alignment	26
4.07 - Reverse Gearbox Direction	27
4.08 - Driveline	27
4.09 - Overrunning Clutch	29
5 - REPAIR PROCEDURES	31
5.01 - Gearbox	31
5.02 - Pulleys	31
5.03 - Rotor Shaft	32
5.04 - Suggested Spare Parts	32
5.05 - Storage	32
6 - TROUBLESHOOTING	34
7 - PRE-DELIVERY CHECKLIST	35
8 - WARRANTY	36
PARTS MANUAL	41

1 - GENERAL INFORMATION

Thank you and congratulations for having chosen our implement. Your new flail shredder is a technologically advanced machine constructed of high quality, sturdy components that will fulfill your working expectations. Read this manual carefully. It will instruct you on how to operate and service your shredder safely and correctly. Failure to do so could result in personal injury and/or in equipment damage.

1.01 - General

The implement described in this manual is to be used with tractors with PTO at 540 rpm and clockwise rotation.



CAUTION: Always ensure that the coupling of the implement with the tractor is done at the same PTO speed and direction of rotation. Do not operate this implement at a PTO speed or direction of rotation other than that shown on the implement. Serious damage can occur to the machine and/or the operator.



CAUTION: Unless otherwise specified, all hardware is metric. Use only metric tools on metric hardware. Other tools that do not fit properly can slip and cause injury.



CAUTION: Right hand and left hand sides of the implement are determined by facing in the direction the implement will travel when going forward (see fig. 2).

Carefully read the Warranty section¹, detailing coverage and limitations of this warranty. **Warranty** is provided for customers who operate and maintain their equipment as described in this manual. Warranty registration is accomplished by the dealer by completing and forwarding the **Warranty Registration** form to the Company, along with a copy of the dealer's invoice. It is in your best interest to ensure that this has been done.

Warranty does not cover the following:

1. Cleaning, transporting, mailing and service call charges.
2. Normal wear items such as belts, blades, bearings, drivelines, shear pins, slip clutches, etc.
3. Depreciation or damage caused by normal wear, accidents, improper maintenance, improper protection or improper use.

¹ See Chapter 8 - Warranty.

4. The use of non-original spare parts and accessories.

Your Authorized Company Dealer has genuine parts in stock. Only these approved replacement parts should be used.

This limited warranty covers defective material and workmanship. The cost of normal maintenance or repairs for accidents or improper use and related labor will be borne by the owner.

1.02 - Model and Serial Number ID

Attached to the frame is an ID plate showing the model and the serial number. Record your implement model and serial number in the space provided below. Your dealer needs this information to give you prompt, efficient service when you order parts.

BEFCO	1781 S. Wesleyan Blvd. — P.O. Box 6036 Rocky Mount, N.C. 27802 — U.S.A. Tel: 1.252.977.9920 Fax: 1.252.977.9718
MODEL:	<input type="text"/>
SERIAL:	<input type="text"/>
VERSION:	<input type="text"/>

2 - SAFETY PRECAUTIONS

Safety is the primary concern in the design and manufacture of our products. Unfortunately our efforts to provide safe equipment can be wiped out by a single careless act of an operator.

In addition to the design and configuration of equipment, hazard control and accident prevention are dependent upon the awareness, concern, prudence and proper training of personnel involved in the operation, transport, maintenance and storage of equipment. It is the operator's responsibility to read and understand all safety and operating instructions in the manual and to follow these.

Allow only properly trained personnel to operate the shredder. Working with unfamiliar equipment can lead to careless injuries. Read this manual, and the manual for your tractor, before assembly or operation, to acquaint yourself with the machines. It is the shredder owner's responsibility, if this machine is used by any person other than yourself, is loaned or rented, to make certain that the operator, prior to operating, reads and understands the operator's manuals and is instructed in safe and proper use.

2.01 - Preparation



1. Before operating equipment read and understand the operator's manual and the safety signs (**see fig. 2**).
2. Thoroughly inspect the implement before initial operation to assure that all packaging materials, i.e. wires, bands, and tape have been removed.
3. Personal protection equipment including hard hat, safety glasses, safety shoes, and gloves are recommended during assembly, installation, operation, adjustment, maintaining and/or repairing the implement.
4. Operate the shredder only with a tractor equipped with an approved Roll-Over-Protective-System (ROPS). Always wear your seat belt. Serious injury or even death could result from falling off the tractor.
5. Clear area to be cut of stones, branches or other debris that might be thrown, causing injury or damage.
6. Operate only in daylight or good artificial light.
7. Ensure shredder is properly mounted, adjusted and in good operating condition.
8. Ensure that all safety shielding and safety signs are properly installed and in good condition.

2.02 - Starting and Stopping



1. Be sure that no one is near the machine prior to engaging or while the machine is working.
2. Be sure the tractor is in "Neutral" before starting engine.
3. Shredder operating power is supplied from tractor PTO. Refer to your tractor manual for PTO engagement and disengagement instructions. Always operate PTO at 540 rpm. Know how to stop the tractor and shredder quickly in case of an emergency.
4. When engaging PTO, the engine rpm should always be low. Once engaged and ready to start cutting, raise PTO speed to 540 rpm and maintain throughout cutting operation.
5. Check the tractor master shield over the PTO stub shaft. Make sure it is in good condition and fastened securely to the tractor. Purchase a new shield if old shield is damaged or missing.
6. After striking an obstacle, disengage the PTO, shut the tractor down, wait for all moving parts to come to a complete stop and thoroughly inspect for damage before restarting.
7. Never engage the PTO until the shredder is in the down position and resting on the ground. Never raise the shredder until all blades have come to a complete stop.
8. To park the vehicle safely, stop vehicle on a level surface (not on a slope), disengage PTO, engage the parking brake, stop the engine, remove the key, and wait for engine and all moving parts to stop before leaving the operator's seat.
9. Stay clear of rotating drivelines. Entanglement in rotating driveline can cause serious injury or death. Wear close fitting clothing. Stop the engine and be sure PTO driveline is stopped before getting near it.

2.03 - Messages and Signs



1. Read and adhere to all safety and operating decals on this machine (**see fig. 2**).
2. Before dismounting tractor: Allow moving parts to stop, stop engine, set brake and remove the key of unattended equipment.
3. Keep away from rotating blades and driveline.
4. Keep guards and shields in place and in good condition.
5. Do not use with bystanders in area.
6. Allow no riders on tractor or shredder.
7. Allow moving parts to stop before repair.
8. Securely support shredder before working underneath.

Additional warning and operating decals are available at no extra charge. Please specify model and serial number when ordering.

Fig. 2 - Safety decals - implement; replace immediately if damaged.

CAUTION

To avoid serious injury:

- Read Operator's Manual before operating, servicing or repairing equipment. Follow all safety rules and instructions. (Manuals are available from your selling dealer).
- Know location and function of controls.
- Keep all shields in place and in good condition.
- Stay clear of power driven parts.
- Never allow riders.
- Never allow children or untrained persons to operate equipment.
- Keep bystanders at a safe distance away from mower during operation.
- Before mowing, clear area of objects that may be thrown by blades.
- Use extra caution on uneven terrain. Decrease speed when turning.
- Tractor must be equipped with a Roll-Over-Protection-System (ROPS) and seatbelt.
- Keep foldable ROPS systems in the "locked up" position at all times.
- Keep seatbelt securely fastened.

Before dismounting or servicing

- Shut off engine and remove key.
- Lock parking brake.
- Wait for all movement to stop
- Lower or block up mower.

900-1118

WARNING

High-pressure hydraulic oil leaks can penetrate skin resulting in serious injury, gangrene or death.

- Check for leaks with cardboard; never use hand.
- Before loosening fittings: lower load, release pressure, and be sure oil is cool.
- Consult physician immediately if skin penetration occurs.

900-088

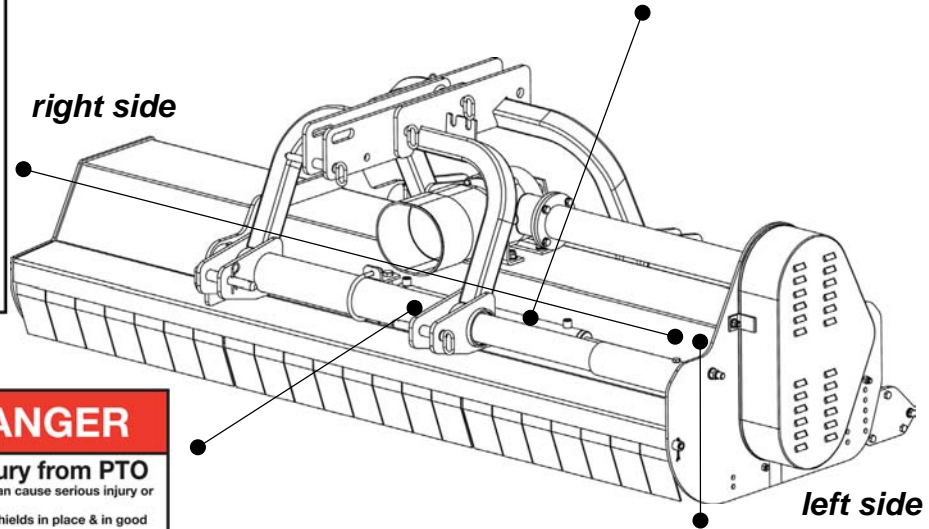

DANGER

Avoid injury from PTO

- Entanglement can cause serious injury or death.
- Keep driveline shields in place & in good condition.
- Keep hands, feet and clothing away.
- Operate only with 540 RPM.

900-1098



Yellow reflective decal (D90-088 only)

DANGER

Moving parts hazard

To prevent serious injury or death from moving parts:

- Keep away! Moving parts can crush and dismember.
- Do not operate without guards and shields in place.
- Disconnect and lockout power source before adjusting and servicing.

900-089



Red reflective decal

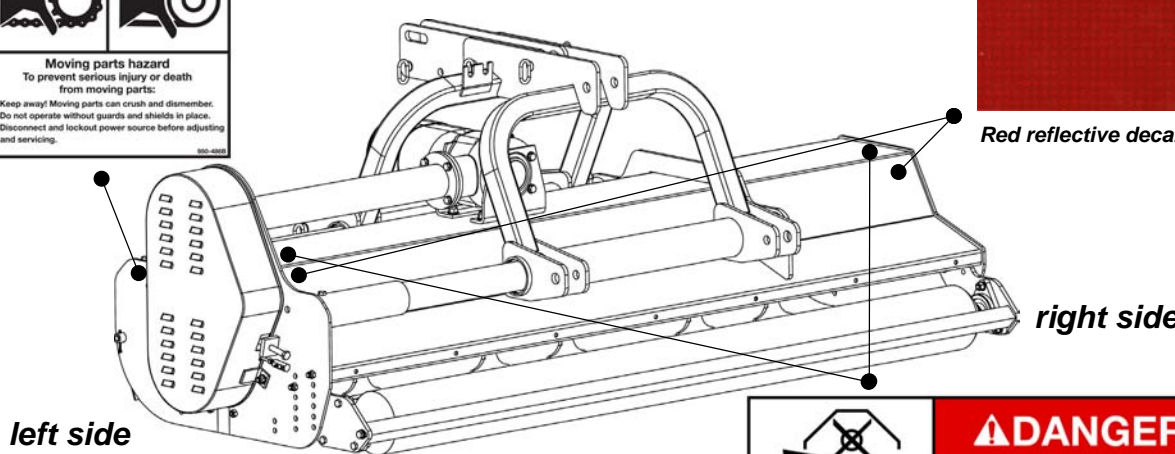

DANGER

Rotating blades hazard

To prevent serious injury or death:

- Keep hands, feet, hair and clothing away from moving parts.
- Do not go under frame when blades are turning or engine is running. Keep others away.
- Disconnect and lockout power source before adjusting or servicing.

Blade contact can cause serious injury or death

900-2098

Safety decals - driveline; replace immediately if damaged.

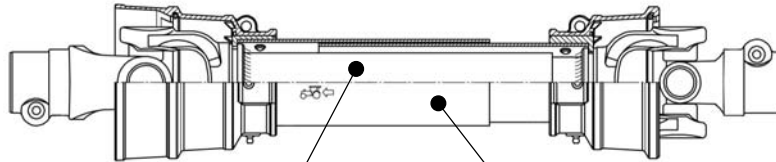

placed on outer tube



placed on outer shield

3 - OPERATION

The Destroyer D90 is a sturdy and easy to use flail shredder. It is especially designed to offer the best performance in cutting and pulverizing corn stalks and other row crops, heavy grass from set a side fields, tree prunings in orchards, municipal mowing and wherever professional, accurate and safe shredding are required. Engineered for tractors from 40 to 90 HP with category 1 or 2 three point hitches (quick hitch compatible), the D90 is available in 60", 72" and 88" cutting widths. All models are equipped with a category 6 driveline with overrunning clutch for 540 rpm PTO's. Flail shredders are also equipped with an hydraulic side shift that allows for easy and hassle free shredding in hard to reach areas such as under tree limbs or near fences.

The hammer type blades turn against the direction of travel and are capable of cutting material up to 2" in diameter. This cutting motion from bottom to top allows for a cleaner finish and ensures safety at all times since all the debris from the mower is blown up and around the rotor of the shredder then straight down to the ground.

Destroyer D90 flail shredders can be either front or rear tractor mounted.

3.01 - Operational Safety



CAUTION: Our shredders are designed considering safety as the most important aspect and are the safest available in today's market. Unfortunately, human carelessness can override the safety features built into our machines. Injury prevention and work safety, aside from the features on our shredders, are very much due to the responsible use of the equipment. It must always be operated prudently following with great care, the safety instructions laid out in this manual.



1. The use of this equipment is subject to certain hazards which cannot be prevented by mechanical means or product design. All operators of this equipment must read and understand this entire manual, paying particular attention to safety and operating instructions, prior to using.
2. Do not operate the tractor and shredder when you are tired, sick or when using medication.
3. Keep all helpers and bystanders at least 100 yards from a flail shredder. Only properly trained people should operate this machine.
4. When this machine is operated in populated areas where thrown objects could injure persons or property, the standard deflector shielding (which is designed to reduce the possibility of thrown objects) must be installed.
5. The majority of accidents involve entanglements on the driveline, injury of bystanders by objects thrown by the rotating blades, and operators being knocked

off the tractor by low hanging limbs and then being run over by the shredder. Accidents are most likely to occur with machines that are loaned or rented to someone who has not read the operator's manual and is not familiar with a flail shredder.

6. Always stop the tractor, set brake, shut off the tractor engine, remove the ignition key, lower implement to the ground and allow shredder blades to come to a complete stop before dismounting tractor. Never leave equipment unattended with the tractor running.
7. Never place hands or feet under shredder with tractor engine running or before you are sure all motion has stopped. Stay clear of all moving parts.
8. Do not allow riders on the shredder or tractor at any time. There is no safe place for riders.
9. Do not operate unless all personnel, livestock and pets are at least 100 yards away to prevent injury by thrown objects.
10. Before backing up, disengage the shredder and look behind carefully.
11. Install and secure all guards and shields before starting or operating.
12. Keep hands, feet, hair and clothing away from moving parts.
13. This flail shredder is designed for use only on tractors with 540 rpm power take off.
14. Never operate tractor and shredder under trees with low hanging limbs. Operators can be knocked off the tractor and then run over by the rotating blades.
15. The rotating parts of this machine have been designed and tested for rugged use. However, they could fail upon impact with heavy, solid objects such as steel guard rails and concrete abutments. Such impact could cause the broken objects to be thrown outward at very high velocities. To reduce the possibility of property damage, serious injury, or even death, never allow the cutting blades to contact such obstacles.
16. Frequently check shredder blades. They should be sharp, free of nicks and cracks and securely fastened.
17. Stop shredder immediately upon striking an obstruction. Turn engine off, remove key, inspect and repair any damage before resuming operation.
18. Stay alert for holes, rocks and roots in the terrain and other hidden hazards. Keep away from drop-offs.
19. Use extreme care and maintain minimum ground speed when transporting on hillside, over rough ground and when operating close to ditches or fences. Be careful when turning sharp corners.
20. Reduce speed on slopes and sharp turns to minimize tipping or loss of control. Be careful when changing directions on slopes. Do not start or stop suddenly on slopes. Avoid operation on steep slopes.
21. When using a unit, a minimum 20% of tractor and equipment weight must be on tractor front wheels. Without this weight, tractor could tip over, causing personal injury or death. The weight may be attained with a front end loader, front wheel weights, ballast in tires or front tractor weights. When attaining a minimum 20% of tractor and equipment weight on the front wheels, you must not exceed the ROPS weight certification. Weigh the tractor and equipment. Do not guess or estimate!

22. Inspect the entire machine periodically². Look for loose fasteners, worn or broken parts, and leaky or loose fittings.
23. Use only the driveline supplied with the shredder. Do not use it if it is missing any shield or safety protection.
24. Pass diagonally through sharp dips and avoid sharp drops to prevent "hanging up" tractor and shredder.
25. Avoid sudden starts and stops while traveling up or downhill.
26. Always cut down slopes; never across the face. Avoid operation on steep slopes. Slow down on sharp turns and slopes to prevent tipping and/or loss of control.

3.02 - Set Up

Notice to dealer: Pre-delivery setup and service including lubrication is the responsibility of the authorized dealer. It is up to him to assure that the machine is in perfect condition and ready to be used. It is his responsibility to ensure that the customer is aware of all safety aspects and operational procedures for the shredder. He must also fill out the Pre-Delivery Checklist³ prior to delivering the shredder.



CAUTION: Stand clear of bands when cutting as they could be under sufficient tension to cause them to fly loose. Take care in removing bands and wire, they often have extremely sharp edges and cut very easily.

Flail shredders may be either front or rear mounted to the tractor. Front mounting application requires a tractor that is equipped with a forward PTO and three point hitch. Setting up the shredder for a front mount application can easily be done at an Authorized Company Dealership and is accomplished by turning the three point hitch and the gearbox 180° (see fig. 3).

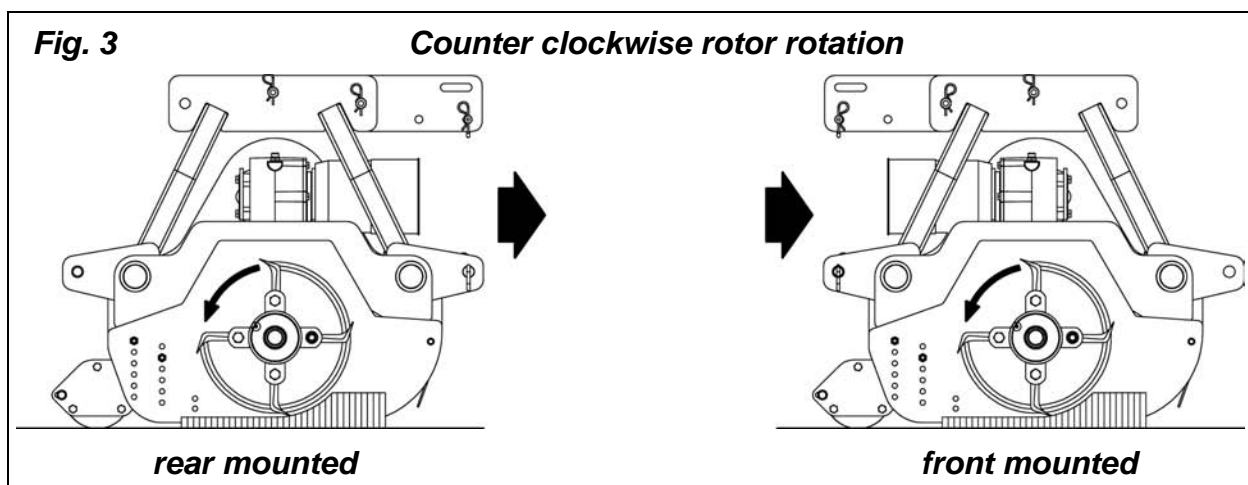

² See Chapter 4 - Maintenance.

³ See Chapter 7 - Pre-Delivery Checklist.

3.03 - Cutting Height Adjustment



WARNING: Keep hands and feet away from moving blades.

Be sure tractor engine is off, parking brake is locked, and key is removed before making any adjustments.

Never rely on the tractor lift system. Install blocks or stands under the shredder deck to prevent it from falling.

The cutting height is the distance from the blades to the ground. It is changed by adjusting the position of the rear roller (see fig. 4). All shredders are equipped with a roller scraper that helps keep the roller clean and the cutting height consistent.

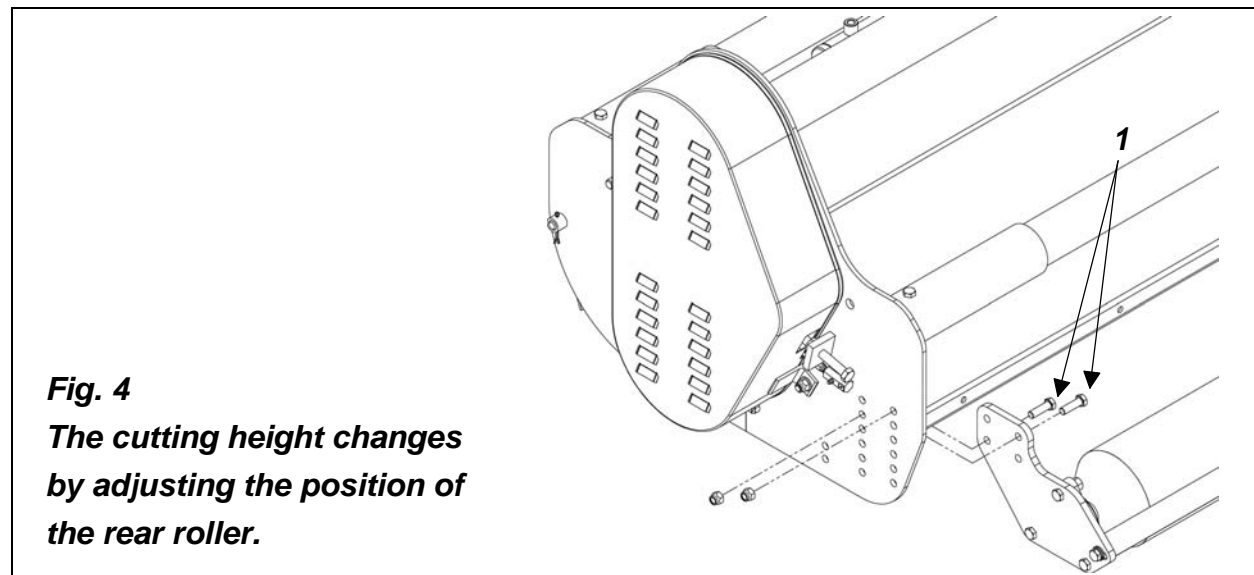

Fig. 4
The cutting height changes by adjusting the position of the rear roller.

The machine has 9 different cutting height positions. The cutting height is adjustable from $\frac{3}{4}$ " to 5" in approximately $\frac{1}{2}$ " increments. Cutting lower than 2" under most circumstances should be avoided. Make sure blades do not touch the ground. Blades that contact the ground will wear out faster and may cause excessive vibration to the rotor.

To change the cutting height do the following (see fig. 4):

1. Unbolt and remove the 4 bolts, 2 on each side, (see #1, fig. 4) that secure the roller height position.
2. Move the roller into its desired position and insert the bolts into two of the available holes. Tighten all 4 bolts. Assembling the roller to the lower holes will increase cutting height while assembling the roller to the higher holes will reduce cutting height.

3. Ensure the left and right roller brackets are in the same hole position in order to maintain a level roller which is parallel to the ground. Be sure the shredder is level and lock the tractor arms so they will not float down or up when cutting.

IMPORTANT: Very low cutting heights should be avoided. Damaging shock loads occur when the blades strike the ground repeatedly. This can cause damage to the flail shredder.

3.04 - Pre-Operational Check

IMPORTANT: Check each of the following, carefully, prior to engaging the equipment:

1. The rotor and roller bearings have been greased.
2. The oil in the gearbox.
3. The driveline cross and bearings have been greased.
4. No wrappings or foreign objects are around the blades, belts or driveline.
5. The blades are properly installed and the blade bolts properly torqued⁴.
6. All hardware is tight.
7. The tractor, to ensure correct direction of PTO and rpm speed.
8. All safety shields and guards are in place and tightly attached.
9. No people or animals are in the work area.
10. When working, make sure the tractor hitch is locked in position so the front of the flail shredder will not float down while shredding.



DANGER: Stay clear of rotating driveline. Entanglement in rotating driveline can cause serious injury. Disengage PTO, wait for all moving parts to come to a complete stop, engage parking brake or place transmission in “Park”, shut off the tractor and remove the key before working around hitch, attaching or detaching driveline, making adjustments, servicing or cleaning the machine.

3.05 - Attaching to the Tractor

Unit may be used on tractors ranging from 40 to 90 HP equipped with a standard PTO⁵ and a category 1 or 2 three point hitch. **Never use this shredder with tractors over 90 HP.**



CAUTION: Check the tractor PTO rpm to ensure it is set at 540 and turns clockwise.

⁴ See Table 1, page 30.

⁵ See Table 2, page 30.



CAUTION: Never attempt to attach the shredder to the tractor or make any adjustments to it without first turning the tractor off.



DANGER: Failure to ensure a secure coupling of the implement to the tractor can cause injury and damage to the implement or tractor. If necessary, wheel weights, front tractor weights and/or tire ballast should be used to improve stability. Be sure that the tractor tire pressure is correct. It is important to strictly follow the safety guidelines and instructions laid out in the tractor operator's manual.

To attach the shredder to the tractor do the following:

1. Back the tractor up to the shredder in order to slip the tractor hitch arms over the hitch pins on the shredder hitch arms. **Turn off the tractor engine.** Secure them in place with the lynch pins.
2. Adjust the tractor sway blocks or chains to remove all side movement.
3. Attach the top link. Adjust tractor top link to allow the shredder, in the working position, to remain as level as possible with respect to the ground.
4. Install the shielded driveline to the tractor by first lining up the splines and depressing the snap pin. Push the yoke onto the PTO shaft as far as it will go. Release the pin and pull back slowly until the pin clicks in place. Repeat this operation on the implement end. Be sure to install the overrunning clutch side of the PTO shaft on the implement.
5. Attach the driveline chains to the tractor and to the shredder to keep the driveline protection from turning. The chains should not be too tight.
6. Ensure the driveline has at least 2" from bottoming out in its shortest working position and has the minimum 6" overlap in its longest working position. Refer to **Section 4.08⁶** of this manual, if it is determined that the driveline is too long and needs to be shortened. Contact your Authorized Company Dealer if it is determined that the driveline is too short for your tractor.

3.06 - Start Up



DANGER: The shredder must always be lowered to the ground before starting tractor engine or engaging PTO lever.

Lower shredder to the ground with the tractor rock shaft control lever until the roller is on the ground and the shredder frame is parallel to the ground. Lock the tractor rock shaft

⁶ See Section 4.08 - Driveline, for instructions on how to determine correct driveline length and procedures for shortening the driveline.

control lever in this position. With the engine idling, slowly engage the PTO drive. Move the throttle lever gradually until the PTO speed indicated on the shredder is obtained. The shredder is designed for a PTO speed of 540 rpm.

Shift the transmission to a slow speed gear and start forward, increase the ground speed by shifting upward until the desired speed is obtained. Do not mow in reverse unless absolutely necessary and only after careful observation of the area behind the shredder.



CAUTION: Do not operate this shredder at a PTO speed or direction of rotation other than that shown on the shredder. Serious damage can occur to the machine and/or the operator.

Before starting to mow, never forget that the **operator is responsible** for the following:

1. Safe and correct driving of the tractor and shredder.
2. To learn precise safe operating procedures for both the tractor and the shredder.
3. To ensure all maintenance and lubrication has been performed on the shredder.
4. To have read and understood all safety aspects for the shredder in the operator's manual.
5. To have read and understood all safety decals on the shredder.
6. Checking the condition of the blades. Worn or damaged blades should be changed before starting⁷.
7. Checking to ensure that the cutting edge is the leading edge of the blade⁸.
8. Checking that there is no wire, weed, grass or other material wrapped around blades.
9. Checking to see if front weights need to be added to the tractor in order to maintain balance.
10. Checking the tractor tires for the proper pressure in accordance with the tractor's operator's manual.
- 11. Checking that the PTO shield, belt shield, front deflector shields and all other shielding are on the machine and securely in place.**
12. Making sure the proper attire is worn. Avoiding loose fitting clothing which can become entangled. Wearing sturdy, tough-soled work shoes and protective equipment for eyes, hands, ears and head. Never operate tractor or implements in bare feet, sandals or sneakers.
13. Checking area for stones, branches and other debris that might be thrown.
14. Ensuring proper lighting is available, sunlight or good artificial lighting.

3.07 - Working Speed

The shredding speed depends on ground conditions, tractor HP, shredding height, and material thickness. Under most conditions a 1 to 4 mph ground speed is best. When mowing in areas with thick prunings of up to 2" in diameter, it is advisable to operate the

⁷ See Section 4.03 - Blade Maintenance.

⁸ See Section 4.03 - Blade Maintenance.

machine at a speed of 1 mph. When mowing light grass, a speed of approximately 4 mph will work best. Only a test run will enable you to gauge the optimal working speed for your conditions. As a rule of thumb, and if the conditions permit, grass dispersion is increased by higher ground speeds.

In order to obtain the best cut possible, always keep the tractor rpm up to the speed indicated on the shredder. When increasing or decreasing shredding ground speed, always use gear selection, not engine speed. This will maintain the constant maximum blade speed necessary for a clean cut.



CAUTION: Do not operate this shredder faster than 6 mph. Serious damage can occur to the machine and/or the operator.

3.08 - Operating Techniques

All of the following factors are important in selecting the proper forward speed:

1. Height of grass.
2. Type of grass.
3. Density of grass.
4. Type of terrain.
5. Grass condition, wet or dry.

For the best results, try cutting the grass at least once per week during growing season. Tall, dense grass should be cut at low speed, while thin medium grass can be cut at a faster ground speed.

Always operate PTO at 540 rpm. This is necessary to maintain proper blade speed and obtain a clean cut.

Under certain conditions, tractor tires may roll some grass down and prevent it from being cut at the same height as the surrounding area. If this occurs reduce the tractor ground speed but maintain a 540 rpm engine speed. The lower ground speed will permit the grass to at least partially rebound. Under some conditions grass will not rebound enough to be cut even, resulting in an uneven appearance. In general, lower cutting height gives a more even cut with less tendency to leave tire tracks. If cut is still not satisfactory, cut the area twice.

Mow extremely tall grass twice. On the first pass use a high cutting height. On the second pass, position the shredder at the desired height and, when practical, mow at a right angle of travel to the first pass.

Plan your pattern to travel straight forward whenever possible.

It is better to cut grass more often, than too short. Short grass deteriorates rapidly in hot weather and invites weed growth during growing season.

If at any time the shredder should jam resulting in belt slippage of 2 or more seconds, raise the shredder and continue for 2-3 minutes. This will allow the pulleys to cool and prolong belt life.



DANGER: Never operate the shredder without first ensuring that all protective devices are properly installed. The shredder blades can throw objects 100 yards or more which could result in personal or property damage.

Pick up all rocks and other debris before shredding. Enter new areas carefully. Cut grass higher at first, allowing shredder to clear hidden objects.



CAUTION: For emergency reasons learn how to stop the tractor and shredder quickly. On the flail shredders always disengage the PTO, lock parking brake, stop engine and allow the shredder blades to come to a complete stop before dismounting the tractor.

3.09 - Hydraulic Side Shift

D90 flail shredders can be offset to facilitate mowing closer to fences or under tree limbs. A double action hydraulic cylinder allows the 60" unit to be offset up to 12" to the right while the 72" and 88" units can be offset up to 16". Two hydraulic remotes are required on the tractor to side shift the shredder left and right.

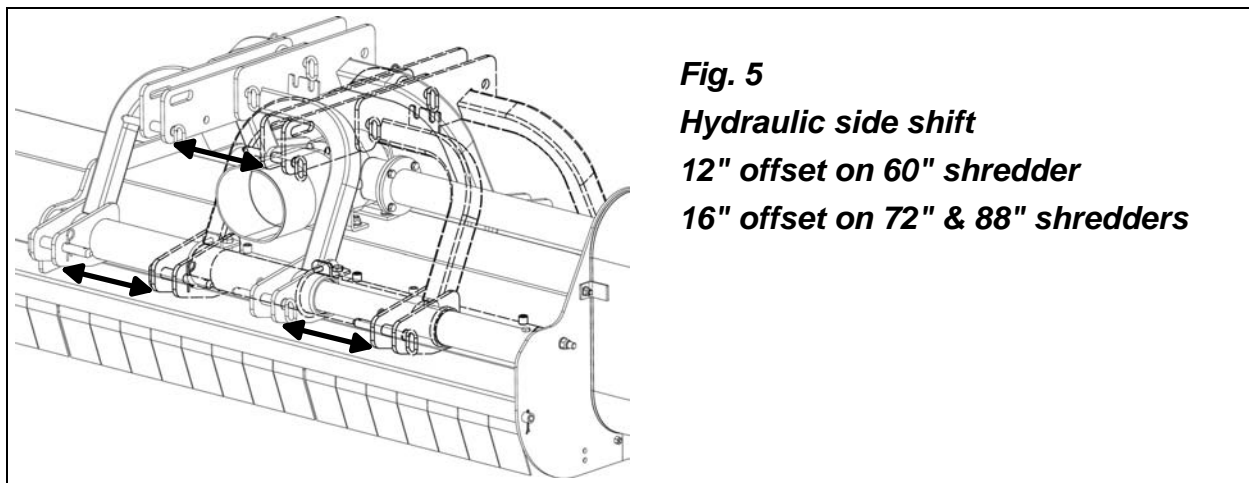

Fig. 5
Hydraulic side shift
 12" offset on 60" shredder
 16" offset on 72" & 88" shredders



WARNING: High pressure hydraulic oil leaks can penetrate skin resulting in injury, gangrene or death. Be sure to relieve any hydraulic oil pressure before disconnecting any lines or pipes between rake and tractor hydraulic system. Check for oil leaks using a cardboard, never use hands.

3.10 - Uneven Terrain



DANGER: Be careful of rollover when operating tractor and shredder over uneven ground.

The following precautions should always be observed when working on uneven terrain:

1. In extremely uneven terrain rear wheel weights, front tractor weights, and/or tire ballast should be used to improve stability.
2. Observe the type of terrain and develop a safe working pattern.
3. Whenever traction or stability is doubtful, first test drive over the terrain with the PTO disengaged.
4. Operate the implement up and down steep slopes, not across slopes, to prevent the tractor from tipping. Avoid sudden stops and starts, and slow down before changing directions on a slope.
5. Pass diagonally through sharp dips and avoid sharp drops to prevent hanging up the tractor and implement.
6. Slow down on sharp turns and slopes to prevent tipping or loss of control.
7. Avoid tipping the shredder while cutting.
8. Watch for holes, roots or other hidden objects. Do not use near the edge of a gully, ditch or stream bank.

3.11 - Removing Shredder from the Tractor



CAUTION: Disengage tractor PTO. Set parking brake. Stop engine and remove key from ignition. Disconnect shredder driveline from tractor PTO shaft. Collapse driveline and store in appropriate place. Disconnect three point linkage and carefully drive tractor away from shredder.

3.12 - Transport



CAUTION: Make sure PTO is disengaged and blades have stopped turning before raising shredder to full transport position. Do not tow tractor and shredder behind other vehicles. Use a properly equipped trailer with heavy tie-downs for towing operations.

Before transporting:

1. Always select a safe ground speed that is appropriate for the terrain.

2. Beware of traffic on public roads. Install a SMV (Slow Moving Vehicle) sign when traveling on roads or streets. Comply with all federal, state and local laws.
3. Reduce ground speed when turning and take care that the implement does not strike obstacles such as trees, fences or buildings.
4. Always disengage PTO before raising the implement to transport position.
5. When raising the shredder be sure the PTO driveline does not hit either the shredder or the tractor.
6. During transport the shredder should not be lifted over 14"-16" from the ground.

4 - MAINTENANCE



DANGER: Stop engine, lock parking brake and remove key before performing any service or maintenance.

Never rely on the tractor lift system. Install blocks or stands under the shredder to prevent it from falling.

Always use personal protection devices, such as glasses or gloves when performing maintenance.

Keep fingers out of slots to prevent injury.

4.01 - Maintenance Safety



1. Good maintenance is your responsibility.
2. Keep service area clean and dry. Be sure electrical outlets and tools are properly grounded. Use adequate light for the job at hand.
3. Make sure there is plenty of ventilation. Never operate the engine of the towing vehicle in a closed building. The exhaust fumes may cause asphyxiation.
4. Make no repair or adjustments with the tractor engine running. Before working on the machine, disengage the PTO, shut off the engine, set the brakes, and remove the ignition key.
5. Be certain all moving parts on attachment have come to a complete stop before attempting to perform maintenance.
6. Never work under equipment unless it is blocked securely.
7. Always use personal protection devices such as eye, hand and hearing protectors, when performing any service or maintenance.
8. Frequently check shredder blades. They should be sharp, free of nicks and cracks and securely fastened.
9. Periodically tighten all bolts, nuts and screws and check that all cotter pins are properly installed to ensure unit is in a safe condition.
10. When completing a maintenance or service function, make sure all safety shields and devices are installed before placing unit in service.
11. After servicing, be sure all tools, parts and service equipment are removed.
12. Never replace hex bolts with less than grade five bolts unless otherwise specified, i.e. shear bolts⁹.
13. Where replacement parts are necessary for periodic maintenance and servicing, genuine replacement parts must be used to restore your equipment to original

⁹ Refer to Table 1 - Torque Specifications, page 30.

specifications. The Company will not claim responsibility for use of unapproved parts and/or accessories and any other damages as a result of their use.

14. Unauthorized modifications to the machine may impair the function and/or safety of the machine and reduce its life. If equipment has been altered in any way from original design, the manufacturer does not accept any liability for injury or warranty.

4.02 - Service

The accompanying illustrations show lubrication points. The chart gives the frequency of lubrication in hours, based on normal operating conditions. Severe or unusual conditions may require more frequent lubrication.

Use a good quality SAE multipurpose type grease for all locations shown. Be sure to clean fittings thoroughly before using grease gun.

Use 90 wt. or 140 wt. gear oil in gearbox.

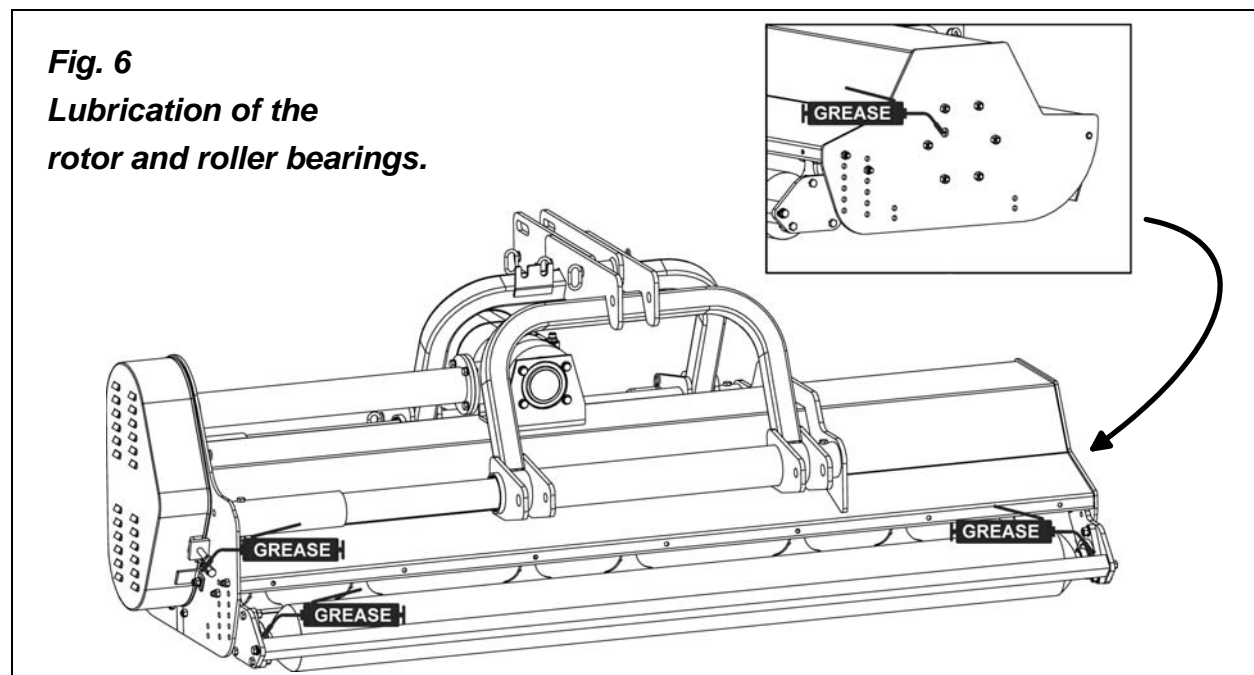

Hourly or whenever an obstacle is hit:

1. Check the conditions of the blades, blade carrier brackets welded to the rotor, proper blade mountings or broken or missing blades. **Even a single missing or broken blade can unbalance the rotor and create serious damage to the shredder or cause grave danger to bystanders.**
2. **Do not continue shredding if even one blade is broken or missing. Broken or missing blades must be replaced immediately¹⁰. Heavily worn blades should be replaced as a complete set in order to maintain a balanced rotor.**
3. Remove any wrappings, weeds, paper, wire, etc., from the blades and rotor.

¹⁰ See Section 4.03 - Blade Maintenance.

Every 8 hours:

1. **Lubricate driveline:** Apply two or three shots of grease to the driveline cross and bearings and the telescoping shafts. See the driveline manufacturer operator's manual for further information on the driveline.
2. **Lubricate roller bearings and rotor support bearings (see fig. 6):** Apply two or three shots of grease to the roller bearings and to the rotor bearings on each side of the machine.
3. **Check gearbox oil level:** It should be between $\frac{1}{2}$ and $\frac{2}{3}$ full. If needed add either SAE 90 wt. or SAE 140 wt. gear oil.

Every 25 hours:

1. **Check hardware tightness;** shredder vibration can loosen bolts¹¹. Check tightness of the hardware periodically.
2. Check belt tension¹².



DANGER: The beginning of abnormal vibrations from the rotor may mean it is out of balance. A single broken or missing blade is enough to cause this. An unbalanced rotor, due to its high rotation speed, can dislodge itself from the side bearing supports thus damaging the shredder and cause serious injury to persons nearby. Always find the source of the vibration. Bring the rotor back in balance by replacing blades, removing wrappings, etc. If this does not remove the vibrations, the rotor may have to be rebalanced at one of our Authorized Company Dealerships.

4.03 - Blade Maintenance



WARNING: To avoid possible injury always wear proper eye and hand protection when servicing shredder blade.

In order for the shredder to work properly, and to always obtain a precision cut with lower HP requirements thus keeping cost down, proper blade maintenance is important. Blades must be kept sharp, at their original length and corners maintained. A blade must be replaced if, due to wear or damage, its original shape has been distorted. Blades should be replaced when their total length is less than 5" or when the hole that the blade bolt is assembled through has ovalized $\frac{5}{64}$ " over its original diameter (**see fig. 7**).

¹¹ See Table 1, page 30.

¹² See Section 4.04 - Belt Tension.

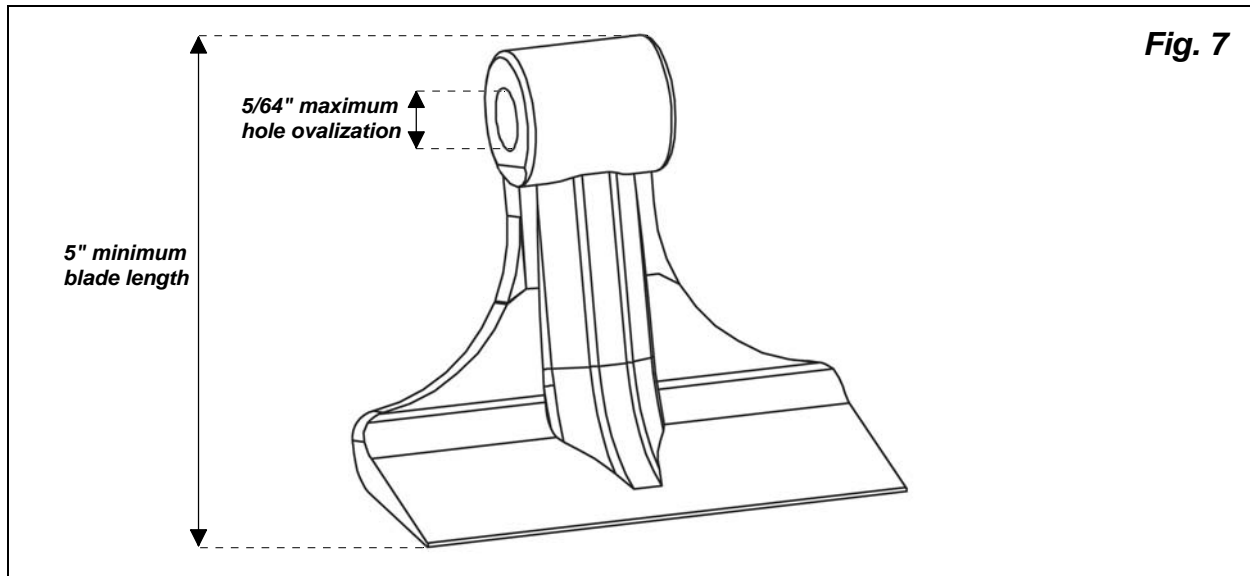

Installing or removing blades

If the shredder blades need to be replaced, do the following (see fig. 8):

1. Loosen and remove the lock nuts.
2. Remove the worn blades from the blade carrier welded onto the rotor. Replace with new blades.
3. Ensure the cutting edge of the blades is the leading edge in the direction of rotation.
4. Replace the bolt and tighten using a new nut then torque to 250 N.m. (185 lb.ft).

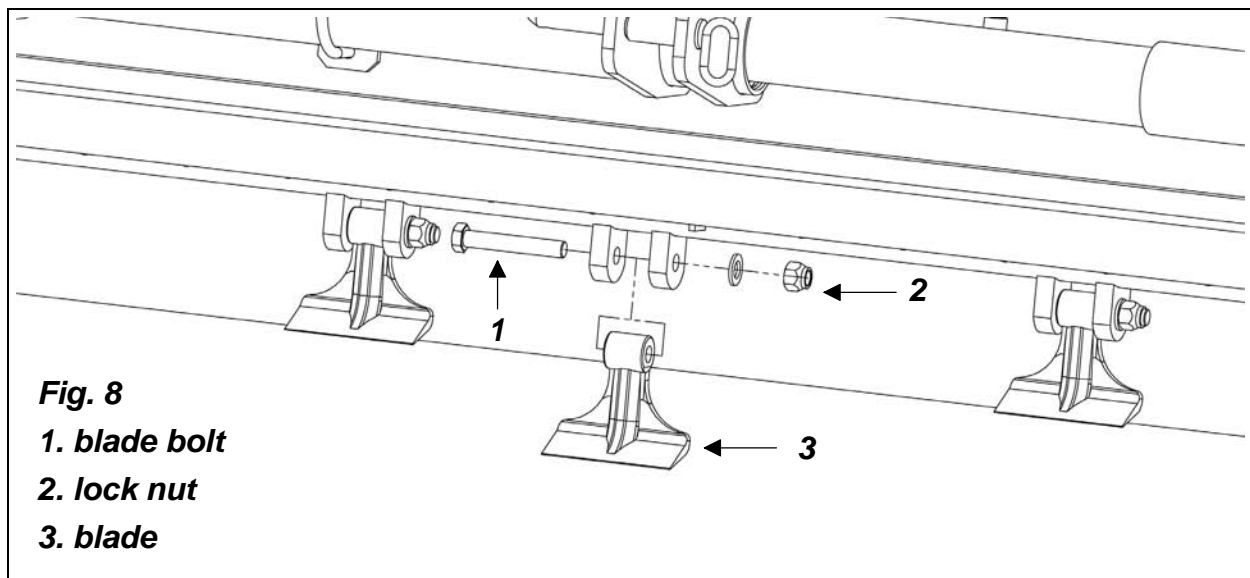

Fig. 8

1. blade bolt
2. lock nut
3. blade



DANGER: Proper torque must be used when tightening the blade retaining bolt. Always use new nuts when replacing blades. If these safety precautions are not followed, the blade could come off during operation and be thrown 100 yards or

more from the shredder. Ensure that once the bolts are tight, the blades are able to pivot freely. This is imperative to not cause damage to the shredder.



DANGER: Always remember the rotor must remain well balanced at all times to avoid dangerous vibrations which can damage the overall structure of the shredder and cause serious injury to any nearby persons. It is therefore recommended that whenever worn blades are changed, the entire set be changed to avoid unbalancing the rotor with blades of different weights. If a single blade or set in a certain area is replaced, it is best to also replace the blade or set of blades opposite to maintain balance.

If after replacing some of the blades, the vibration remains or increases, it is best to then replace the entire set.

If this still does not remove the vibrations, the shredder should be taken to an Authorized Company Dealership to determine if it is necessary to rebalance the rotor.



CAUTION: When the blades are replaced, it is important that all the blades are of the same type and weight. A rotor unbalanced by different blades can damage the shredder.



CAUTION: Do not substitute blades or any bolt for the blade retaining bolt. Company blades and blade retaining bolts are specially made for this application. Using non original parts can effect the quality of cut and may also cause damage to the shredder.

4.04 - Belt Tension

Belt tension control

Check the tension of the four belts (**see fig. 9**) by applying a force of 12-15 lb. pushing against each belt halfway between the pulleys. The belt deflection should be between $\frac{5}{16}$ "- $\frac{3}{8}$ ".

Belt tension adjustment

The **Destroyer D90** flail shredder is equipped with a lateral belt transmission with a manually loaded belt tensioner. The tension is applied by a tensioner pulley and is regulated with an adjustment bolt (**see #6, fig. 9**) which protrudes from the belt shield.

To adjust the tension do the following (**see fig. 9**):

1. Loosen the locking nut.
2. Screw the adjustment nut until the correct belt tension is reached.

3. Tighten the locking nut.

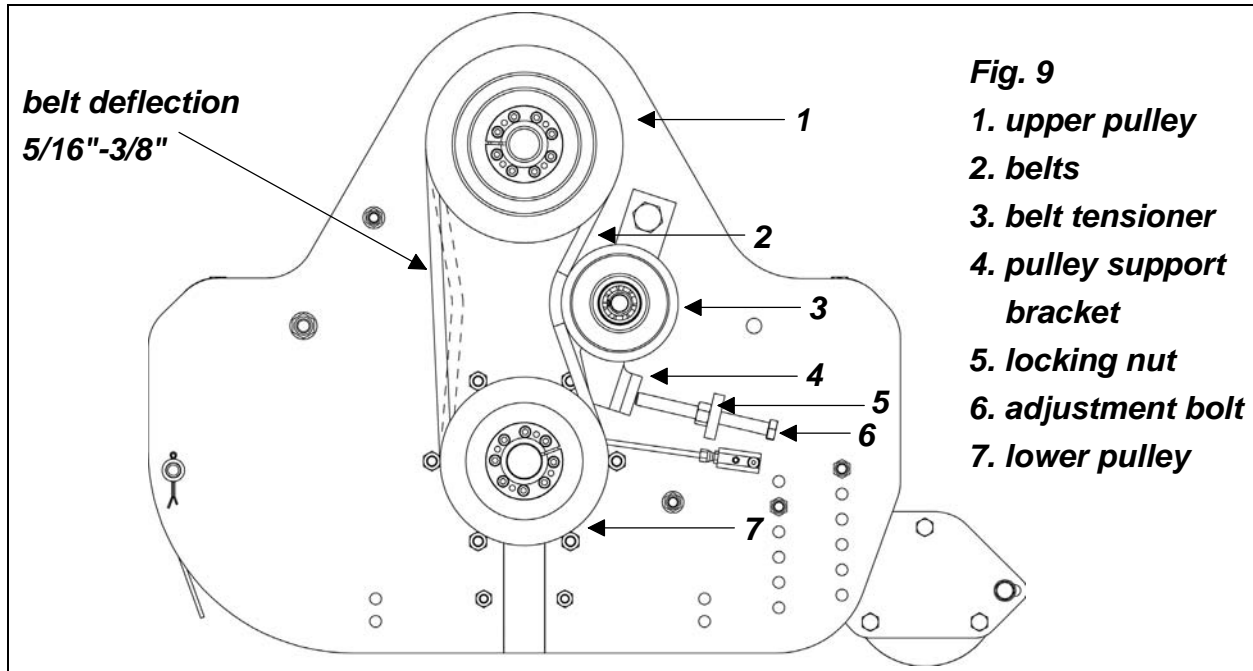

Fig. 9

1. upper pulley
2. belts
3. belt tensioner
4. pulley support bracket
5. locking nut
6. adjustment bolt
7. lower pulley

4.05 - Belt Replacement

If the belts have been stretched or damaged to the point where the proper tension can not be obtained they must be changed. All four belts must be changed at the same time.

To replace the belts do the following:

1. With the shredder stopped supported by stands, remove the belt shield. Clean the belts, pulleys and shield of grass, dust and dirt.
2. Loosen the locking nut and unscrew the adjustment bolt (**see fig. 9**).
3. Remove the old belts one at a time and replace them with the new belts using a screwdriver if needed.
4. Tighten the belts with the adjustment bolt then secure it with the locking nut.
5. Ensure that the belts are at the proper tension (**see fig. 9**).
6. Replace the belt shield.

4.06 - Pulley Alignment

For proper operation and extended belt life the upper and lower pulley of the shredder need to always work aligned to one another. After replacing the belts, place a straight edge over two sides of each pulley to check their alignment (**see fig. 10**). If the pulleys are aligned the straight edge should lay evenly across the surface of both pulleys¹³.

¹³ See Section 5.02 - Pulleys, for instructions on removing and replacing pulleys.

Fig. 10

Apply a straight edge over the sides of the pulleys to check their alignment.

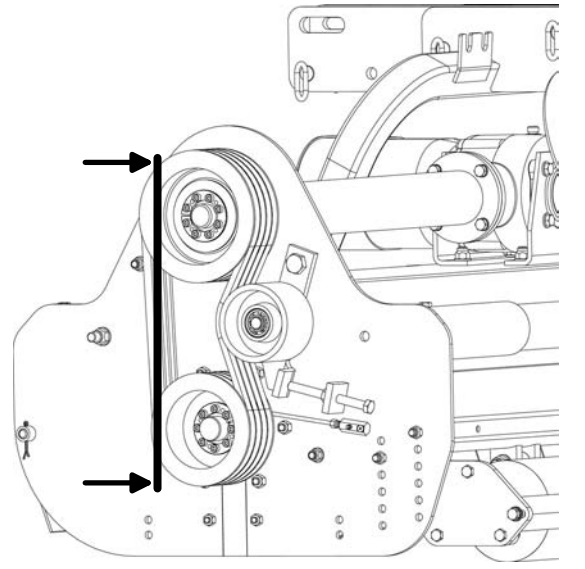

4.07 - Reverse Gearbox Direction

The D90 flail shredder in its standard configuration is to be used with a tractor that has a shaft that turns clockwise.

It is possible to reverse the direction of rotation of the output shaft on the gearbox and therefore to use the flail shredder with a tractor that has a shaft with a counter clockwise rotation.

To reverse the direction it is necessary to move the ring gear to the other side of the PTO shaft and to replace the overrunning clutch with a left-turning clutch. This operation entails opening the drive transmission. We recommend this be done only at an Authorized Company Dealership.

Note: The flail shredder comes with a PTO driveline equipped with a right-turning overrunning clutch (clockwise). Always check the direction of rotation on the tractor's PTO to be sure it is the same as the overrunning clutch. If the tractor comes with a left-turning PTO (counter clockwise) the overrunning clutch must be changed to left-turning as well.

4.08 - Driveline



DANGER: Only use the original driveline supplied with this shredder and always with the safety shielding.

Carefully read and file away the driveline operator's manual supplied by the manufacturer. The following does not substitute the information found in the driveline manual.

IMPORTANT: Always check driveline length during initial setup and when connecting to a different tractor.

In the collapsed position the driveline should be approximately 2" from bottoming out to prevent possible damage to the tractor or implement. When the driveline is in the maximum extended position, the ideal minimum overlap of the two halves should be approximately 6" (see fig. 11).

Fig. 11

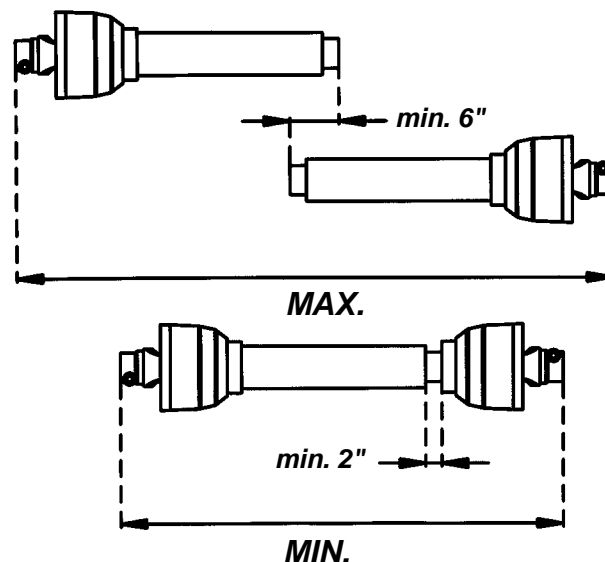

If determined that the driveline is too long, follow these procedures to adjust the length:

1. Separate the two driveline halves. Connect one half to the tractor PTO and the other half to the shredder.
2. Raise and lower the shredder with the 3 point hitch to find the position where the driveline is shortest. Hold the half shafts side by side and mark the desired length on the outer female tube guard leaving a 1¹/₂" gap between the end of the guard tube and bell guard.
3. Cut off both guard tubes the same amount as marked in step 2.
4. Shorten both drive tubes the same amount as guard tubes.
5. De-burr and clean filings from drive tubes and apply grease to outside of inner telescoping tube.
6. Reassemble the driveline halves and connect to tractor and shredder. Raise and lower shredder again to be sure driveline does not bottom out in its shortest position and has a minimum overlap of 6" in the longest position.
7. Install both driveline safety chains. One should be hooked in a hole on the outer driveline yoke shield and to the tractor to restrict outer shield rotation. The second one should be hooked in a hole on the inner driveline yoke shield and to the implement to restrict inner shield rotation.

If determined that the driveline is too short for your tractor, contact your Authorized Company Dealer.









CAUTION: Always work with the driveline as straight as possible. This will prolong its life and that of its components. It is advised not to work at an angle greater than 15 degrees.

4.09 - Overrunning Clutch

The shredder is supplied with a PTO driveline that comes equipped with an overrunning clutch. The PTO yoke end is attached to the tractor's PTO, while the end with the overrunning clutch is attached to the shredder. The purpose of the overrunning clutch is to transmit power in one direction only.

The overrunning clutch is indispensable for use on very fast operating machines, because when the rotation is suddenly halted, the inertia reverses the direction of rotation which could cause implement or tractor damage and put the operator or bystander in danger.

TABLE 1 - TORQUE SPECIFICATIONS

Metric (ISO) treaded bolts head marking							Inch (SAE) treaded bolts head marking								
	Class 5.8		Class 8.8		Class 10.9			Grade 2		Grade 5		Grade 8			
Bolt size mm	Thread mm	N.m	ft-lb	N.m	ft-lb	N.m	ft-lb	Bolt size inch	Thread inch tpi	N.m	ft-lb	N.m	ft-lb	N.m	ft-lb
M5	0.8	4	3	6	4	9	7	1/4"	20	7	5	11	8	16	12
M6	1	6	4	10	7	15	11	1/4"	28	8	6	13	10	19	14
M8	1.25	16	12	25	18	36	27	5/16"	18	15	11	24	17	33	25
M8	1	17	13	26	19	38	28	5/16"	24	17	13	26	19	37	27
M10	1.5	31	23	48	35	71	52	3/8"	16	27	20	42	31	59	44
M10	1.25	33	24	51	38	75	55	3/8"	24	31	23	47	35	67	49
M10	1	35	26	53	39	78	58	7/16"	14	43	32	67	49	95	70
M12	1.75	54	40	84	62	123	91	7/16"	20	48	36	75	55	106	78
M12	1.5	56	41	87	64	128	94	1/2"	13	66	48	102	75	144	106
M12	1.25	59	44	90	66	133	98	1/2"	20	75	55	115	85	163	120
M14	2	84	62	133	98	195	144	9/16"	12	95	70	147	109	208	154
M14	1.5	94	69	142	105	209	154	9/16"	18	106	79	164	121	232	171
M16	2	131	97	206	152	302	223	5/8"	11	132	97	203	150	287	212
M16	1.5	141	104	218	161	320	236	5/8"	18	149	110	230	170	325	240
M18	2.5	181	133	295	218	421	310	3/4"	10	233	172	361	266	509	376
M18	2	196	145	311	229	443	327	3/4"	16	261	192	403	297	569	420
M18	1.5	203	150	327	241	465	343	7/8"	9	226	167	582	430	822	606
M20	2.5	256	189	415	306	592	437	7/8"	14	249	184	642	473	906	668
M20	1.5	288	212	454	335	646	476	1"	8	339	250	873	644	1232	909
M22	2.5	344	254	567	418	807	595	1"	12	371	273	955	704	1348	995
M22	1.5	381	281	613	452	873	644	1-1/8"	7	480	354	1077	794	1746	1288
M24	3	444	327	714	526	1017	750	1-1/8"	12	539	397	1208	891	1958	1445
M24	2	488	360	769	567	1095	808	1-1/4"	7	677	500	1519	1120	2463	1817
M27	3	656	484	1050	774	1496	1103	1-1/4"	12	750	553	1682	1241	2728	2012
M27	2	719	530	1119	825	1594	1176	1-3/8"	6	888	655	1992	1469	3230	2382
M30	3.5	906	668	1420	1047	2033	1499	1-3/8"	12	1011	746	2268	1673	3677	2712
M30	2	1000	738	1600	1180	2250	1659	1-1/2"	6	1179	869	2643	1949	4286	3161
M36	4	1534	1131	2482	1830	3535	2607	1-1/2"	12	1326	978	2974	2194	4823	3557

When using lock washers with nuts, increase torque values by 5%.

TABLE 2 - DESTROYER D90 FLAIL SHREDDER - TECHNICAL FEATURES

Series D90, for tractors up to 90 HP, PTO 540 rpm, 3 point hitch cat. 1 & 2												
Model	HP	Working width	Overall width	Weight lb.	Rotor rpm/min	Blades tip speed ft/min	Hydraulic side-shift	# Hammers	Cutting height	# Belts & Type	Driveline w/overrunning clutch 1 3/8"	
D90-060	40-90	60"	69"	1,257	1,961	8,388	12"	16	3/4"-5"	4 XPBX	ASAE 6 th . cat	
D90-072	40-90	72"	81"	1,345	1,961	8,388	16"	20	3/4"-5"	4 XPBX	ASAE 6 th . cat	
D90-088	40-90	88"	96"	1,491	1,961	8,388	16"	24	3/4"-5"	4 XPBX	ASAE 6 th . cat	

5 - REPAIR PROCEDURES



CAUTION: All repair procedures must be done by authorized dealerships. It is not recommended that untrained individuals perform any repair work. The following operations are detailed for qualified personnel only.

5.01 - Gearbox

To remove the gearbox from the frame do the following:

1. Disengage the belt tensioner pulley by releasing the adjustment bolt (see #6, fig. 9)¹⁴.
2. Remove the belts¹⁵.
3. Unbolt the bolts holding the gearbox to the frame.
4. Unbolt the nuts which hold the gearbox to the drive tube.

If it is necessary to replace any part on the inside of the gearbox, it is important to replace oil seals or gaskets to ensure a tight fit when reassembling.

To replace the gearbox, follow the above instructions in reverse order.

5.02 - Pulleys

To remove the pulleys do the following:

1. Remove the belt cover.
2. Disengage the belt tensioner pulley by releasing the adjustment bolt (see #6, fig. 9)¹⁶.
3. Remove the top and bottom split lock bushings by removing all the screws that hold them and transferring the required number of screws into the push-off threads. Tighten the screws in a crosswise pattern in several steps until bushings disengage.
4. Remove pulleys.

To replace the pulleys do the following:

1. Slide the top pulley on the drive shaft ensuring it is flush with the spacer.
2. Slide the bottom pulley on the rotor shaft ensuring it is flush to the snap ring.
3. Insert the top and bottom split lock bushing, place the screws in the locking bores and hand tighten the screws. Using a torque wrench set at 30 lb.ft (40 N.m), tighten the screws in a crosswise pattern in several steps.
4. Place a straight edge across both pulleys to verify their alignment (see fig. 10).

¹⁴ See Section 4.04 - Belt Tension.

¹⁵ See Section 4.05 - Belt Replacement.

¹⁶ See Section 4.04 - Belt Tension.

Note: For proper pulley alignment it is important to ensure that the top pulley is assembled flush on the spacer and the bottom pulley is assembled flush on the snap ring.

5.03 - Rotor Shaft

To remove the rotor do the following:

1. Remove the belt cover.
2. Disengage the belt tensioner pulley by releasing the adjustment bolt (see #6, fig. 9)¹⁷.
3. Remove the belts¹⁸.
4. Remove bottom pulley from the left side of the rotor¹⁹.
5. Remove the bolts that hold the locking plate situated under the pulley then remove the locking plate.
6. Remove the grease fitting on the left side of the rotor and the grease fitting tube.
7. Remove the grease fitting on the right side of the rotor.
8. Remove the bolts that attach the right and left rotor supports to the frame.
9. Slide the rotor from the side panels.
10. Remove the snap ring that holds the right rotor support bearing to the rotor.
11. Remove the snap ring that holds the pulley to the left side of the rotor.
12. Remove the left and right rotor supports from the rotor.

To replace the rotor, follow the above instructions in reverse order.

5.04 - Suggested Spare Parts

It is suggested that the following spare parts be kept on hand for the shredder at all times to prevent a minor problem from delaying work.

Description	Quantity
Blades	1 set
Blade bolts and nuts	1 set
Belts	4

5.05 - Storage

After seasonal use it is important to perform the following for prolonged storage:

1. Wash the shredder carefully.
2. Inspect the shredder and replace worn or damaged parts.
3. Tighten all hardware.
4. Grease all areas indicated under Maintenance²⁰.

¹⁷ See Section 4.04 - Belt Tension.

¹⁸ See Section 4.05 - Belt Replacement.

¹⁹ See Section 5.02 - Pulleys.

²⁰ See Chapter 4 - Maintenance.

5. Loosen the belts if the shredder is to be stored for an extended length of time.
6. Cover the shredder from the elements in order to have it in perfect condition for the start of the next season.



WARNING: Be sure to store the implement on a hard level surface and away from people especially children.

6 - TROUBLESHOOTING



WARNING: Be sure tractor engine is off, parking brake is locked, and key is removed before making any adjustments.

PROBLEM	POSSIBLE CAUSE	SOLUTION
Uneven cutting.	Machine not parallel to the ground. Blades are worn or bent. Loose belts.	Roller is not in the same adjustment hole pattern. The tractor lift arms are not lifting equally. Change blades. Adjust belt tension.
Grass not cut and/or bent over.	Wrappings around rotor. Wet grass. Grass too high. Tractor rpm too slow.	Remove wrappings. Allow grass to dry. Raise shredder, shift to lower gear, make two passes over grass. Mow grass high 1 st . pass, 2 nd . pass cut to desired height. Increase tractor rpm, check engine and PTO speeds.
Belts squeal.	Belts slipping due to loose belts. Belts slipping due to high grass.	Tighten belts. Raise shredder, shift to lower gear, make two passes over grass. Mow grass high 1 st . pass, 2 nd . pass cut to desired height.
Excessive blade wear.	The cutting height is too low.	Raise the cutting height.
Shredder vibrates.	Worn, broken or bent blades. Shredder not running at proper PTO speed. Object wrapped around rotor. Rotor out of balance.	Replace blades. Set tractor throttle for 540 rpm. Remove object. Balance rotor.
Noisy shredder.	Loose components. Excessive rpm. Low oil in gearbox.	Tighten hardware. Back off tractor rpm to 540. Fill to proper level.
Striping or windrowing.	Worn, broken or bent blades. Grass not being picked up after tractor tires tracks. Shredder not running at rated PTO rpm. Shredder not level. Wrapping or material buildup.	Replace blades. Grass is too high. Cut in two passes at a slower ground speed. Set tractor throttle for 540 rpm. Level shredder with tractor hitch arms. Clean rotor.

7 - PRE-DELIVERY CHECKLIST

To the dealer: Inspect the machine thoroughly after assembly to assure it is functioning properly before delivering it to the customer. The following checklist is a reminder of points to cover. Check off each item as it is found satisfactory or after proper adjustment is made.

- Gearbox oil level.
- Guards and shield properly fastened.
- Lubrication of grease fittings.
- All hardware properly tightened.
- All decals properly located and readable (**see fig. 2**).
- Blades properly installed, blade bolts and nuts tightened.
- Overall condition (touch up scratches, clean and polish).
- Test run, check for excessive vibration or overheating of bearings.
- Operator's Manual.

Review the Operator's Manual with the customer. Explain the following:

- Warranty.
- Safe operation and service.
- Correct machine installation and operation.
- Daily and periodic lubrication, maintenance and inspections.
- Troubleshooting.
- Operational procedures and storage.
- Parts and service.
- Fill out the Pre-Delivery Checklist and Warranty Registration form.
- Give customer the Operator's Manual and encourage the customer to read the manual carefully.

IMPORTANT: Warranty is not valid unless Pre-Delivery Checklist and Warranty Registration form in Operator's Manual is completed in detail and mailed to the Company.

Model Number: _____

Serial Number: _____

Delivery Date: _____

Dealer's Signature: _____

8 - WARRANTY

BEFCO's responsibility will be limited to substitution of the acknowledged defective merchandise to the same place of delivery as the previous one was supplied.

1. LIMITED WARRANTY

BEFCO, Inc. herein referred to as the Company, warrants its machines and related accessories, hereafter referred to as the Machine, to be free from defects in material and workmanship, for a period of twelve (12) months from the date of invoice to the first registered owner; this limited warranty does not apply to common wear items and excludes belts, shear pins, oil, grease, tires, tubes, hydraulic hoses, knives and PTO shafts.

Labor will be reimbursed at \$40.00 per hour based on BEFCO's time schedule.

Cost of transport to the servicing dealer is the responsibility of the customer.

Warranty coverage shall not be transferable from the first owner to any subsequent owner.

2. DISCLAIMER OF ALL OTHER WARRANTIES AND REMEDIES

Neither the Company nor any company affiliated with the Company makes any warranties, representations or promises, expressed or implied, as to the quality, performance or application of its products other than those set forth herein and does not make any implied warranty of merchantability or fitness.

The only remedies the purchaser has in connection with the breach, or performance of any warranty on the Company's Machine are those set forth herein. In no event will the dealer, the Company, or any company affiliated with the Company, be liable for:

- a. Injuries or damages of any kind or nature, direct, consequential or contingent to person or property.
- b. Any expenses incurred by the owner to repair, replace or rework any allegedly defective item.
- c. Any loss, cost, forfeiture or damages (including loss of profits; loss of crops; loss because of delay in field operations; any expenses or loss incurred for labor, supplies, substitute machine rental; liabilities of the owner to its customers or third persons; and all other consequential damages, losses, liabilities or damages for any other reasons) whether direct or indirect, and whether or not resulting from or contributed to by the default or negligence of the Company, its agents, employees and subcontractors which might be claimed as a result of the use or failure of the equipment delivered.

The Company's liability based on this limited warranty or any other applicable laws shall be limited to replacement or refund of the purchase price of the product.

The limited warranty extended herein gives you specific rights and you may also have other rights which vary from state to state. Neither the dealer nor the Company personnel has the authority to make any representation or to modify the terms and limitations of this warranty in any way.

Other than the limited warranty extended hereby there is no other expressed warranty in connection with the design, safety or use of any of the Company's products except as to title. All implied warranties are expressly disclaimed pursuant to the terms of this warranty.

3. CUSTOM WORK

If the Machine is used for commercial purposes such as custom work, the period warranted for the Machine is limited to six (6) months from the date of delivery to the first registered owner and does not cover any labor charges incurred.

4. RENTAL

If the Machine is used for rental purposes the period warranted for the Machine is limited to thirty (30) days from the date of delivery to the first registered owner and does not cover any labor charges incurred.

5. REGISTRATION

In order to qualify for coverage on this limited warranty, the product and name of the original purchaser must be registered with the Company by a completed Machine Pre-Delivery Checklist and Warranty Registration along with a copy of the dealer's invoice to the first registered owner to the Company within fourteen (14) days after the date of delivery to the original purchaser.

6. WARRANTY SERVICE

Warranty Service must be performed by a dealer authorized by BEFCO. If the warranty service requested is approved, the owner shall pay only for labor beyond the rate allowed, for overtime labor, and for any mileage charge for transporting the equipment to and from the dealer's shop. It is assumed that the dealer has the appropriate general and special tools to service the Machine. Time required for replacement of knives, oil, grease and to remove excessive dirt from the Machine is not subject to reimbursement by the Company. The owner is required to clean the Machine before presenting it to the dealer for service work. The Machine must be delivered within thirty (30) days after failure date by the owner to the dealer to be eligible for warranty consideration.

7. UNAPPROVED SERVICE OR MODIFICATION

All obligations of the Company under this limited warranty shall be terminated if:

- a. Proper service and operation instructions as outlined in the Operator's Manual and on the instruction sticker on the Machine, are not followed.
- b. The Machine is modified or altered in any way not approved by the Company.
- c. The Company does not receive a copy of the dealer's invoice to the first registered owner within fourteen (14) days from the date of delivery.
- d. The Company has not been paid in full, by the dealer, for the Machine.

8. ACCIDENTS AND NORMAL MAINTENANCE

This limited warranty covers defective material and workmanship. It does not cover depreciation or damage caused by normal wear, accidents, improper maintenance, improper protection or improper use. The costs of normal maintenance or repairs for accidents or improper use, and related labor will be borne by the owner.

9. REPLACEMENT PARTS

BEFCO, Inc. warrants replacement parts to be free from defect in material and workmanship for a period of thirty (30) days from the date of delivery to the original purchaser.

WARRANTY REGISTRATION

BEFCO, Inc.
P.O. Box 6036
Rocky Mount, NC 27802-6036

Tel: (252) 977.9920 - Fax: (252) 977.9718

Dealer _____ Acct. # _____	Retail Customer _____
Street _____ Country _____	Street _____
Town _____ State _____ Zip _____	Town _____ State _____ Zip _____
Date of delivery _____ Invoice # _____	Phone _____
Model # _____ Serial # _____	
<p>Pre-Delivery Checklist:</p> <p><input type="checkbox"/> Oil in gearbox.</p> <p><input type="checkbox"/> Greased fittings.</p> <p><input type="checkbox"/> Safety guards in place.</p> <p><input type="checkbox"/> All hardware tight.</p> <p><input type="checkbox"/> Bolts torqued correctly.</p> <p><input type="checkbox"/> Attached unit to tractor. Yes/No.</p> <p><input type="checkbox"/> Field adjusted. Yes/No.</p> <p><input type="checkbox"/> Test run. Dry/Infield.</p> <p><input type="checkbox"/> Safety decals.</p> <p><input type="checkbox"/> Operator's Manual.</p> <p>The machine described above, has been prepared for delivery according to the Pre-Delivery Checklist and the Customer has been instructed in its care and operation and the condition of warranty.</p>	<p>Tractor make: _____</p> <p>Model: _____; HP _____</p> <p>Type of operation: Private homeowner, Landscaping, Commercial maintenance, Golf Course, Municipality, Turf Farm, others: _____</p> <p>Approximate number of acres machine will be used on annually: _____</p> <p>I hereby acknowledge that: I have received and accepted delivery of the machine described. The equipment was checked thoroughly for loose or missing parts and has been adjusted in accordance with the Pre-Delivery Checklist. I have read and understand the nature and extent of the warranty and understand clearly that there were and are no other representations of warranties either expressed or implied, made by anyone. I have been advised on proper operation, maintenance and lubrication procedure of this equipment. I have been instructed on and do understand the application, limitation and capacities this equipment was designed and recommended for, all as described in the Operator's Manual and literature published by the Company.</p>
Inspected by: _____	
Date: _____	Date: _____
Dealer's Signature: _____	Customer's Signature: _____

This registration along with a copy of the invoice must be sent to BEFCO, Inc. within 14 days of date of purchase.

Sender:

Fold here

*Place stamp
here*

BEFCO, Inc.

Warranty Department

P.O. Box 6036

Rocky Mount, NC 27802-6036

Cut along this line



BEFCO®

Parts Manual

DESTROYER

Heavy Duty Flail Shredder

D90-060, D90-072, D90-088

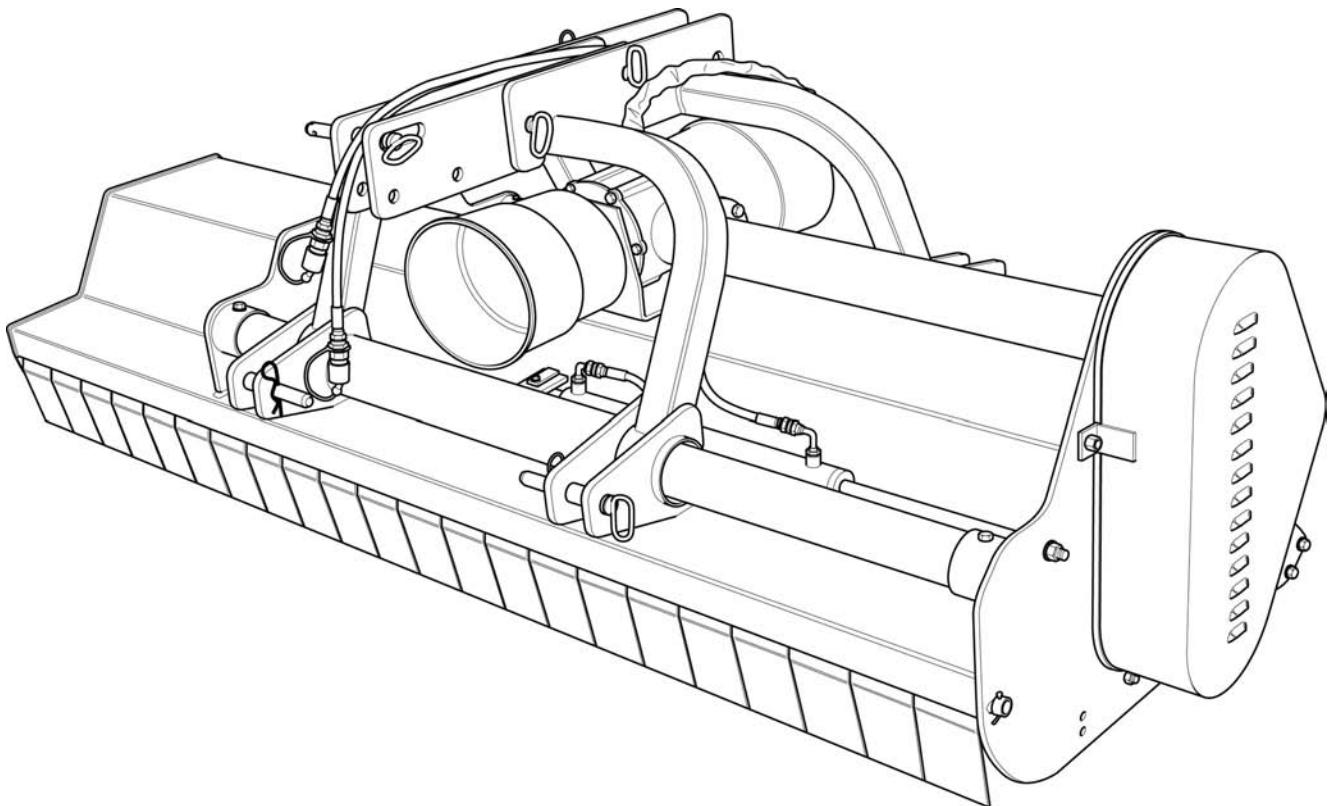

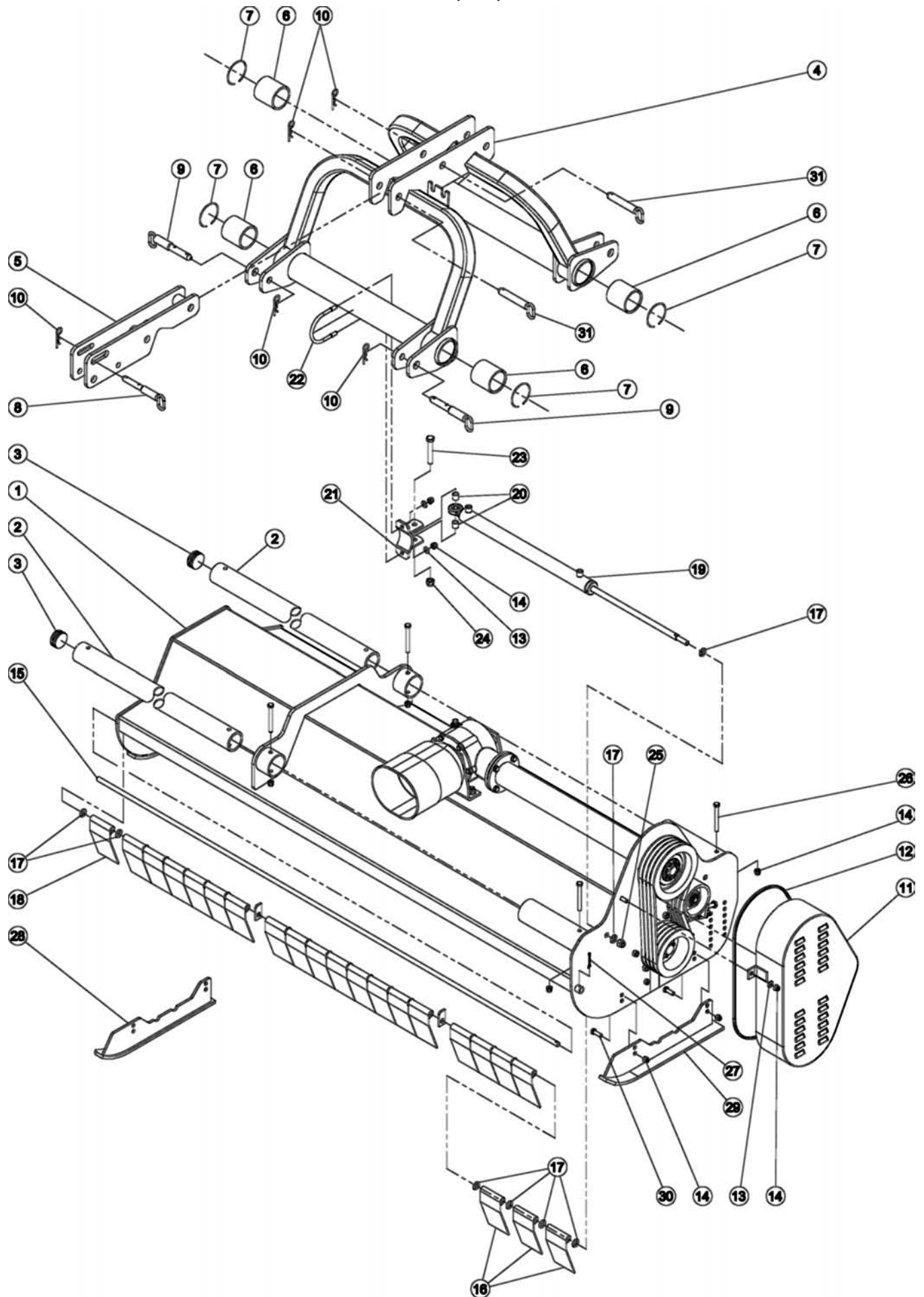

Ref.	Part #	Description	Qty.
1	016-3002	Frame D90-060	1
	026-3002	Frame D90-072	1
	036-3002	Frame D90-088	1
2	016-3031	Guide tube D90-060	2
	026-3031	Guide tube D90-072	2
	036-3031	Guide tube D90-088	2
3	006-3033	Rubber cap Ø70	2
4	006-3422	Double three point hitch	1
5	006-3431	Bracket, top hitch	1
6	006-3058	Bushing	4
7	006-3060	Ring SB 90	4
8	006-3061	Pin, top hitch	1
9	006-3065	Pin, hitch	2
10	009-1507	Hairpin cotter Ø4 Z	5
11	006-3251	Belt cover	1
12	006-3255	Rubber strip	1
13	000-2265	Washer, flat Ø12 Z	4
14	001-3345	Nut ES M12-1.75 Z TK	12
15	016-3345	Deflector rod D90-060	1
	026-3345	Deflector rod D90-072	1
	036-3345	Deflector rod D90-088	1
16	006-3348	Deflector D90-060	15
	006-3348	Deflector D90-072	18
	006-3348	Deflector D90-088	22
17	000-8568	Washer, flat Ø16	-
18	006-3350	Deflector, narrow	1
19	006-3365	Hydraulic cylinder D90-060	1
	006-3366	Hydraulic cylinder D90-072, D90-088	1
20	006-3374	Spacer	2
21	006-3375	Mounting bracket, cylinder	1
22	006-3380	U bolt	1
23	000-6566	Bolt HH M16-2.00x100 C8.8 Z P	1
24	002-6314	Nut ES M16-2.00 Z TK	1
25	002-0105	Nut ES M16-1.50 Z TK	1
26	001-1292	Bolt HH M12-1.75x110 C8.8 Z P	4
27	011-2087	Pin, split Ø4x50 Z	1
28	016-3472	Skid, right (option)	1
29	026-3472	Skid, left (option)	1
30	000-7255	Bolt HH M12-1.75x35 C8.8 Z F	4
31	006-3435	Pin, top hitch	2

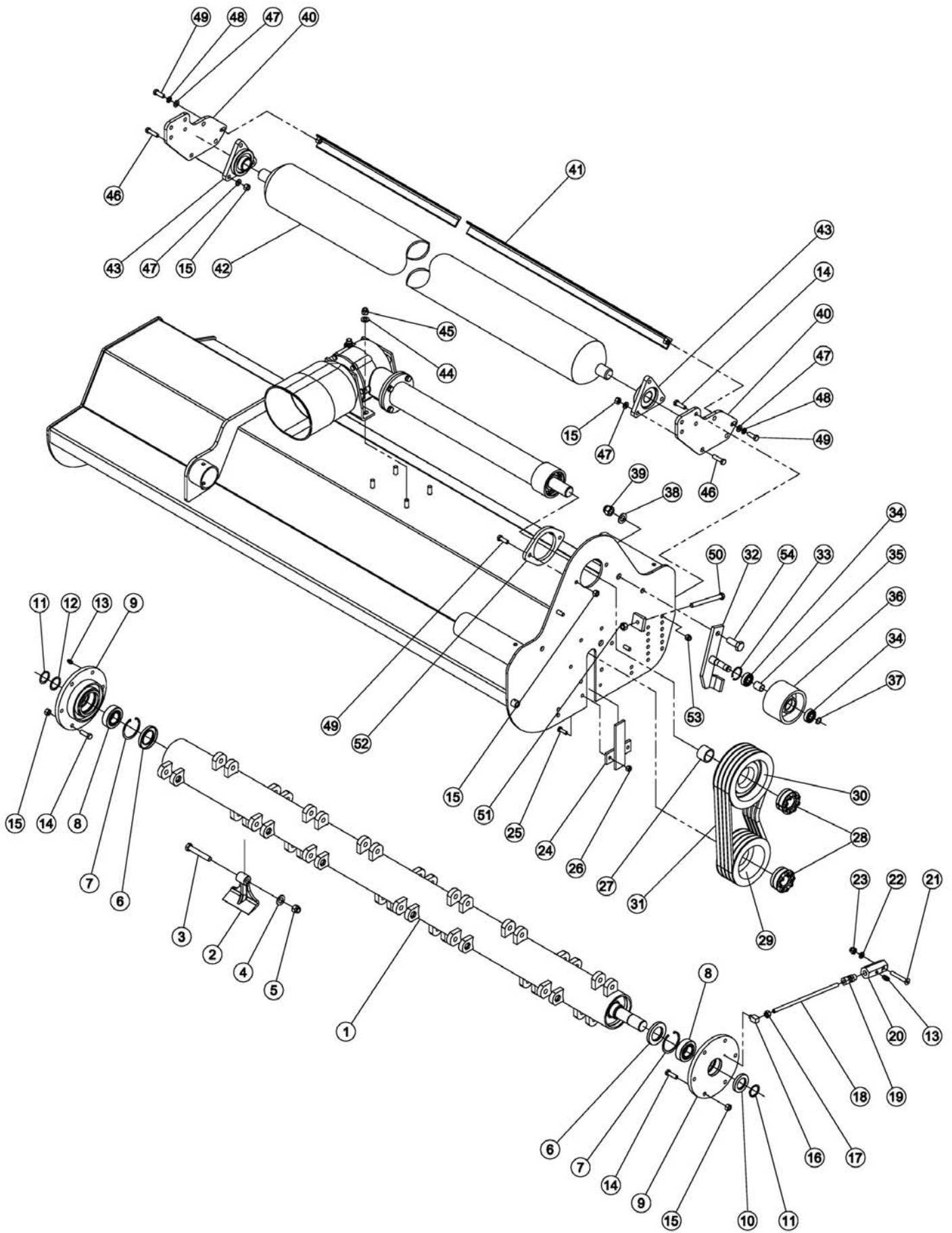

Ref.	Part #	Description	Qty.
1	016-3102	Rotor D90-060	1
	026-3102	Rotor D90-072	1
	036-3102	Rotor D90-088	1
2	006-3114	Hammer D90-060	16
	006-3114	Hammer D90-072	20
	006-3114	Hammer D90-088	24
3	006-3116	Bolt HH M16-1.50x100 C10.9 Z P; D90-060	16
	006-3116	Bolt HH M16-1.50x100 C10.9 Z P; D90-072	20
	006-3116	Bolt HH M16-1.50x100 C10.9 Z P; D90-088	24
4	000-8568	Washer, flat Ø16 D90-060	16
	000-8568	Washer, flat Ø16 D90-072	20
	000-8568	Washer, flat Ø16 D90-088	24
5	006-3117	Nut ES M16-1.50 C8 Z TK; D90-060	16
	006-3117	Nut ES M16-1.50 C8 Z TK; D90-072	20
	006-3117	Nut ES M16-1.50 C8 Z TK; D90-088	24
6	000-7094	Oil seal 52.85.10	2
7	000-1154	Snap ring, inner Ø80	2
8	006-1161	Bearing 22208 E	2
9	006-3141	Rotor support	2
10	001-0192	Oil seal 40.68.10	1
11	000-8138	Snap ring, outer Ø40	2
12	005-3248	Spacer washer 40x50x2	1
13	005-1129	Grease fitting M06-1.00	2
14	002-3265	Bolt HH M12-1.75x40 C8.8 Z F	16
15	003-0064	Nut PT M12-1.75 C6 Z TK	20
16	005-3155	Grease fitting M06-1.00 90°	1
17	501-603B	Nut HH M06-1.00 C6 Z TK	1
18	005-9908	Grease fitting tube	1
19	005-3615	Connector Ø6	1
20	005-3616	Grease fitting block	1
21	005-9525	Bolt CS M06-1.00x40 C8.8 Z F	1
22	005-0166	Washer, flat Ø6 Z	1
23	005-0165	Nut ES M06-1.00 Z TK	1
24	006-3035	Locking plate	1
25	000-1278	Bolt HH M10-1.50x30 C8.8 Z F	2
26	003-0156	Nut PT M10-1.50 C6 Z TK	2
27	006-3220	Spacer	1
28	005-3630	Split lock bushing Ø40x80	2
29	006-3213	Pulley SPB 180x4	1
30	006-3218	Pulley SPB 212x4	1
31	006-3215	Belt XPBX 1340	4
32	006-3222	Pulley support	1
33	005-0144	Snap ring, inner Ø47	1
34	005-0142	Bearing 6204-2RS	2
35	006-3232	Spacer	1
36	006-3227	Belt tensioner pulley	1
37	005-0145	Snap ring, outer Ø20	1
38	004-6555	Washer, flat Ø20 Z	1
39	009-0178	Nut ES M20-2.50 Z TK	1
40	006-3072	Roller arm	2

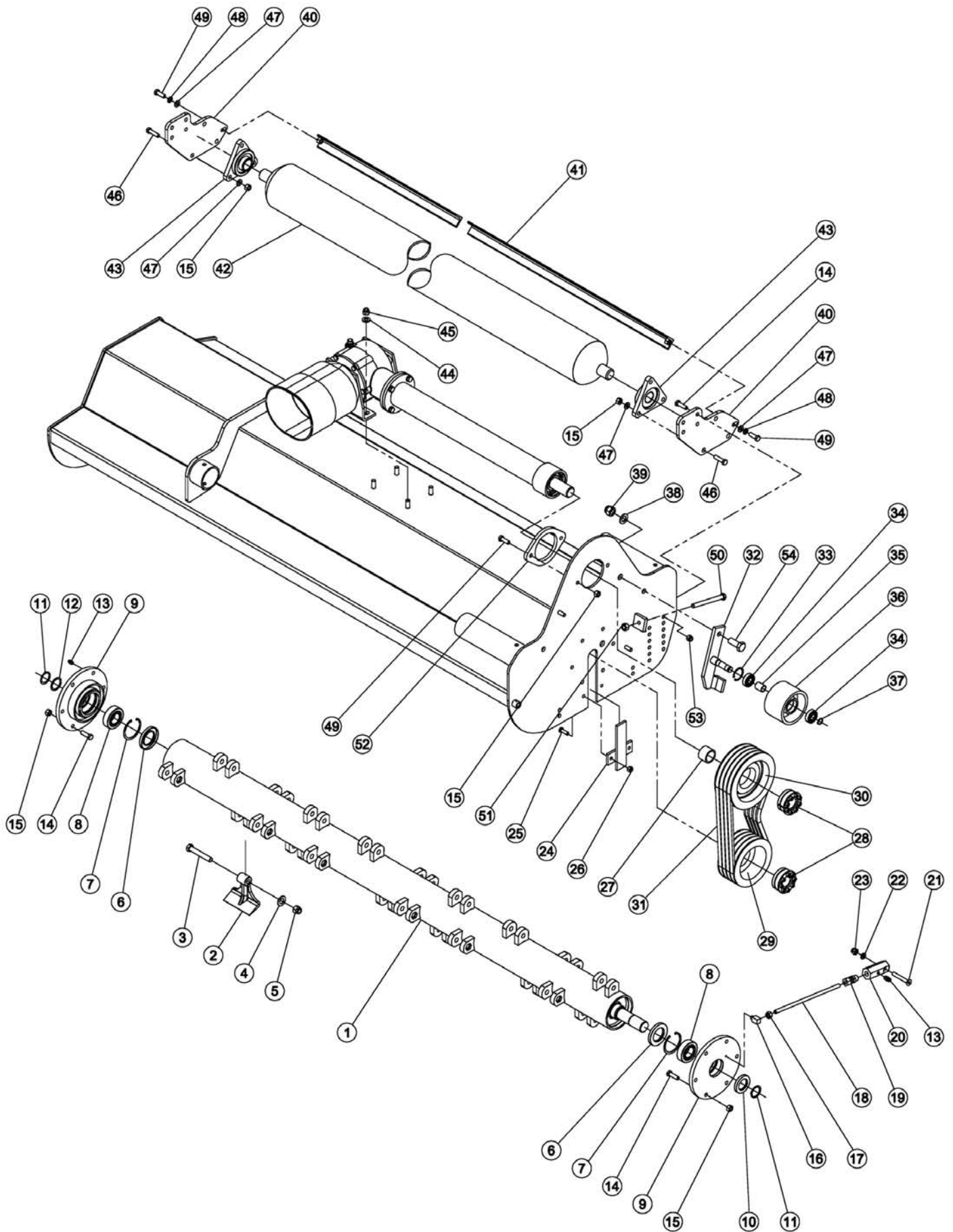

Ref.	Part #	Description	Qty.
41	015-9448	Roller scraper D90-060	1
	025-9448	Roller scraper D90-072	1
	035-9448	Roller scraper D90-088	1
42	016-3087	Roller D90-060	1
	026-3087	Roller D90-072	1
	036-3087	Roller D90-088	1
43	005-9873	Support USFTE 208	2
44	009-1435	Washer, flat Ø14	4
45	000-7224	Nut ES M14-2.00 Z TK	4
46	001-6748	Bolt HH M14-2.00x45 C8.8 Z P	6
47	000-2265	Washer, flat Ø12 Z	8
48	000-1077	Washer, lock Ø12 Z	2
49	000-7255	Bolt HH M12-1.75x35 C8.8 Z F	4
50	006-3238	Bolt HH M14-2.00x150 C8.8 Z F	1
51	000-1019	Nut HH M14-2.00 C6 Z TK	1
52	006-3318	Support plate, drive shaft tube	1
53	001-3345	Nut ES M12-1.75 Z TK	4
54	006-3225	Bolt HH M20-2.50x50 C8.8 Z F	1

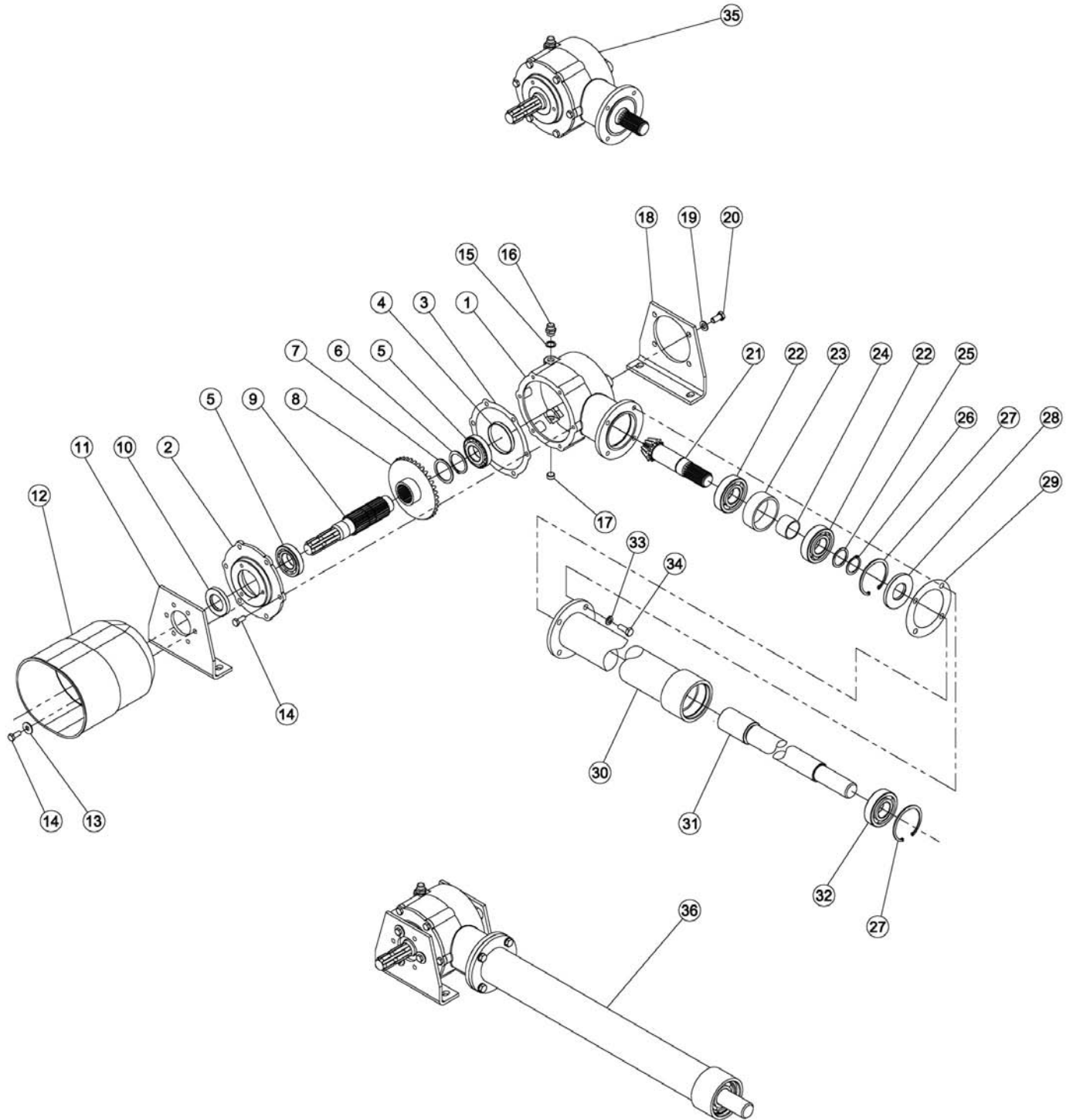

Ref.	Part #	Description	Qty.
1	005-3405	Gearbox housing	1
2	005-3409	Cover, gearbox housing	1
3	018-0206	Gasket 2/10	-
	028-0206	Gasket 5/10	-
4	005-3421	Cap	1
5	003-0201A	Bearing 30208	2
6	002-5115	Snap ring, outer Ø50	1
7	005-5324	Spacer washer 50x62x2	1
8	006-3282	Ring gear	1
9	006-3281	Input shaft	1
10	006-3274	Oil seal 40.72.10	1
11	006-3329	Front plate	1
12	006-3352	PTO shaft protection	1
13	003-0157	Washer, flat Ø10 Z	3
14	003-3176	Bolt HH M10-1.50x25 C8.8 Z F	9
15	000-6691	Gasket	1
16	000-1107A	Breather cap	1
17	005-3446	Drain plug	1
18	006-3331	Rear plate	1
19	000-2265	Washer, flat Ø12 Z	4
20	000-3037	Bolt HH M12-1.75x25 C8.8 Z F	4
21	006-3283	Pinion gear	1
22	000-1148A	Bearing 6308	2
23	005-3257	Spacer	1
24	005-3253	Spacer	1
25	005-3248	Spacer washer 40x50x2	1
26	000-8138	Snap ring, outer Ø40	1
27	000-8137	Snap ring, inner Ø90	2
28	005-4290	Oil seal 40.90.8	1
29	005-3259	Gasket 3/10	-
	015-3259	Gasket 5/10	-
30	016-3299	Complete tube drive shaft D90-060	1
	026-3299	Complete tube drive shaft D90-072	1
	036-3299	Complete tube drive shaft D90-088	1
31	016-3308	Drive shaft D90-060	1
	026-3308	Drive shaft D90-072	1
	036-3308	Drive shaft D90-088	1
32	000-8136	Bearing 6308-2RS	1
33	000-1077	Washer, lock Ø12 Z	4
34	001-5255	Bolt HH M12-1.75x30 C8.8 Z F	4
35	050-0688	Gearbox, complete	-
36	016-3262	Gearbox & drive shaft, complete D90-060	-
	026-3262	Gearbox & drive shaft, complete D90-072	-
	036-3262	Gearbox & drive shaft, complete D90-088	-

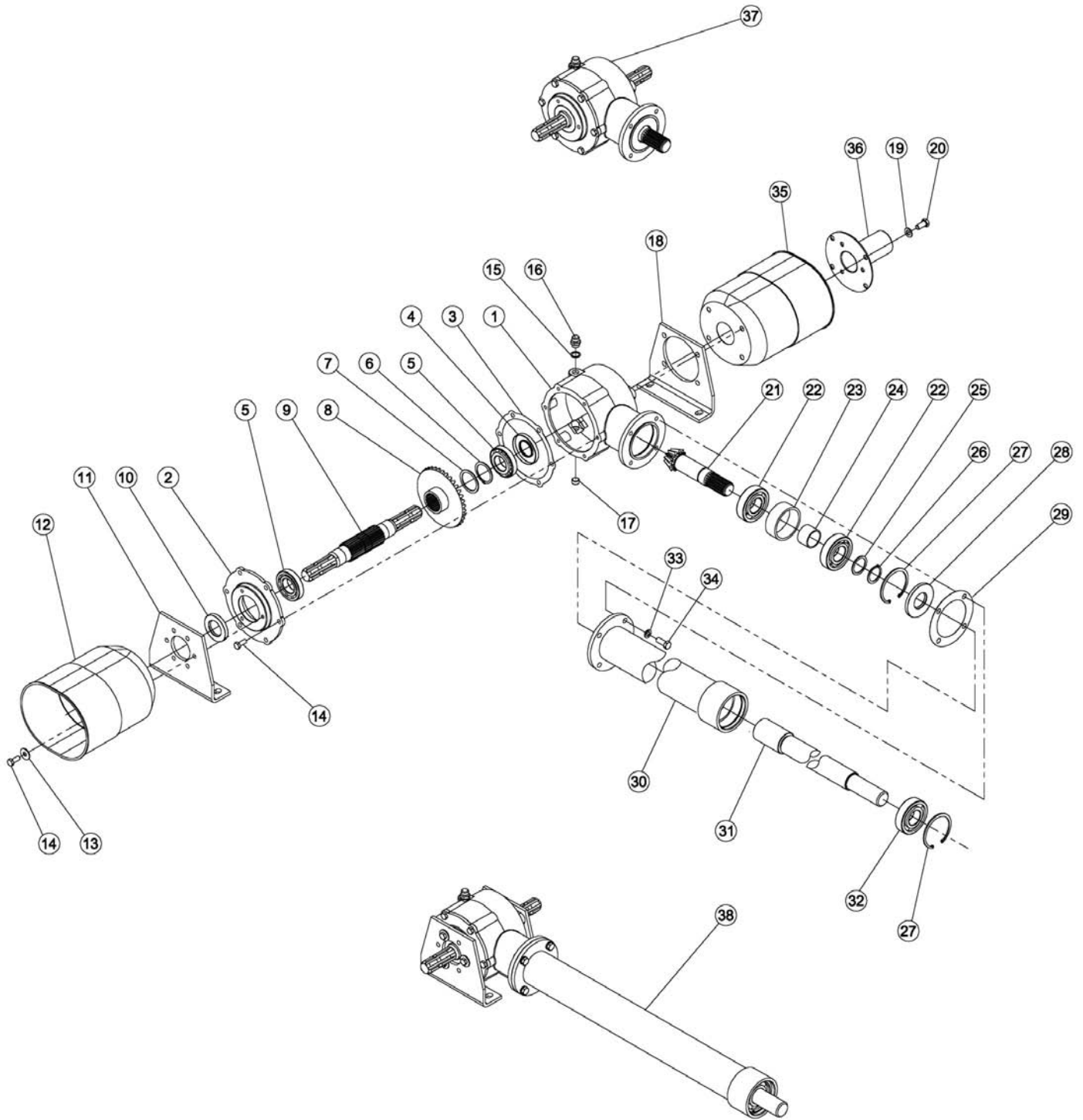

Ref.	Part #	Description	Qty.
1	005-3405	Gearbox housing	1
2	005-3409	Cover, gearbox housing	1
3	018-0206	Gasket 2/10	-
	028-0206	Gasket 5/10	-
4	000-6684	Oil seal 40.80.10	1
5	003-0201A	Bearing 30208	2
6	002-5115	Snap ring, outer Ø50	1
7	005-5324	Spacer washer 50x62x2	1
8	006-3282	Ring gear	1
9	006-3456	Input shaft, double	1
10	006-3274	Oil seal 40.72.10	1
11	006-3329	Front plate	1
12	006-3352	PTO shaft protection, front	1
13	003-0157	Washer, flat Ø10 Z	3
14	003-3176	Bolt HH M10-1.50x25 C8.8 Z F	9
15	000-6691	Gasket	1
16	000-1107A	Breather cap	1
17	005-3446	Drain plug	1
18	006-3331	Rear plate	1
19	000-2265	Washer, flat Ø12 Z	4
20	000-3037	Bolt HH M12-1.75x25 C8.8 Z F	4
21	006-3283	Pinion gear	1
22	000-1148A	Bearing 6308	2
23	005-3257	Spacer	1
24	005-3253	Spacer	1
25	005-3248	Spacer washer 40x50x2	1
26	000-8138	Snap ring, outer Ø40	1
27	000-8137	Snap ring, inner Ø90	2
28	005-4290	Oil seal 40.90.8	1
29	005-3259	Gasket 3/10	-
	015-3259	Gasket 5/10	-
30	016-3299	Complete tube drive shaft D90-060	1
	026-3299	Complete tube drive shaft D90-072	1
	036-3299	Complete tube drive shaft D90-088	1
31	016-3308	Drive shaft D90-060	1
	026-3308	Drive shaft D90-072	1
	036-3308	Drive shaft D90-088	1
32	000-8136	Bearing 6308-2RS	1
33	000-1077	Washer, lock Ø12 Z	4
34	001-5255	Bolt HH M12-1.75x30 C8.8 Z F	4
35	006-3353	PTO shaft protection, rear	1
36	006-3463	Protection	1
37	050-0689	Gearbox w/double transmission, complete	-
38	016-3452	Gearbox & drive shaft, complete w/double transmission D90-060	-
	026-3452	Gearbox & drive shaft, complete w/double transmission D90-072	-
	036-3452	Gearbox & drive shaft, complete w/double transmission D90-088	-

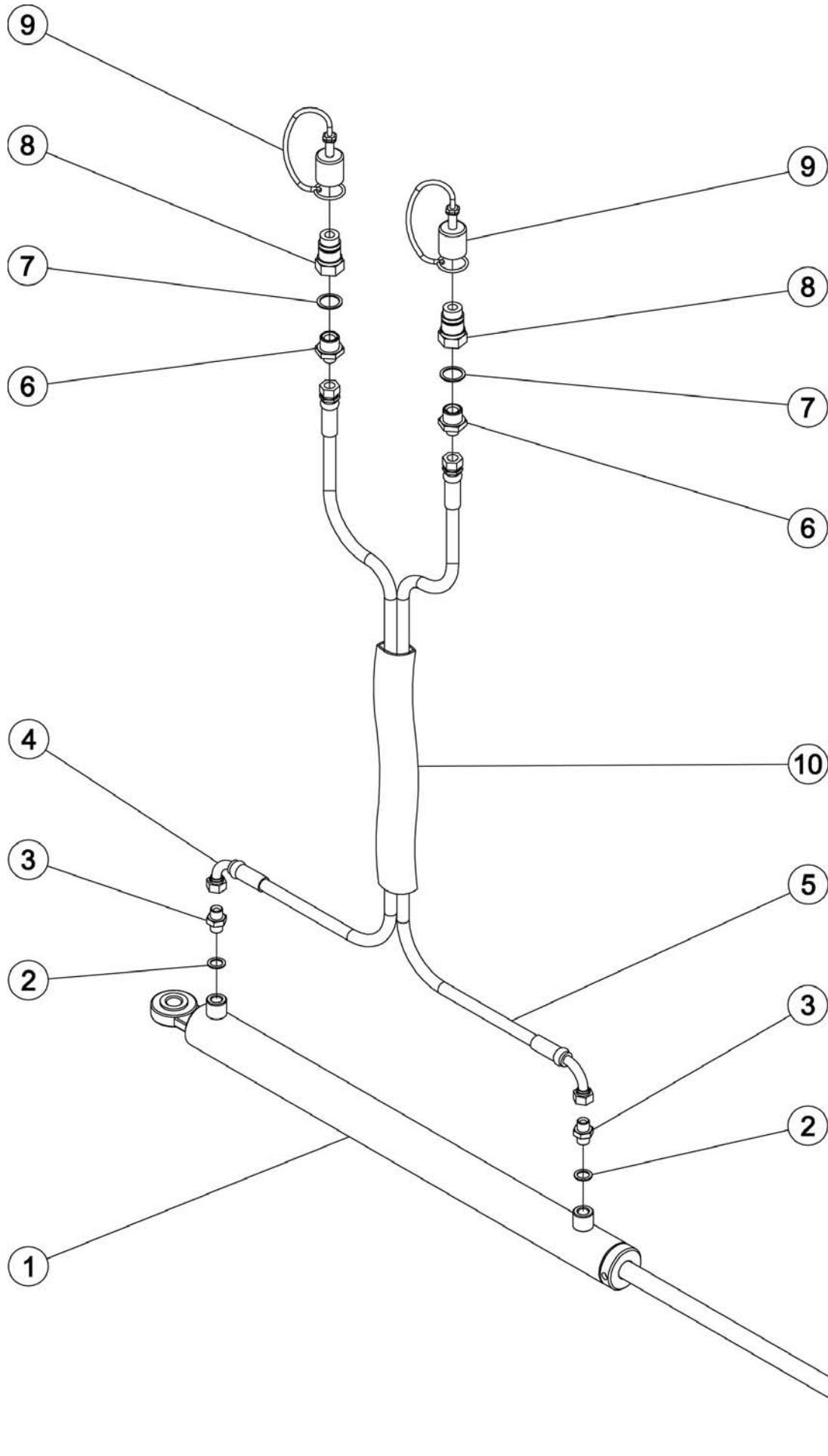

Ref.	Part #	Description	Qty.
1	006-3365	Hydraulic cylinder D90-060	1
	006-3366	Hydraulic cylinder D90-072, D90-088	1
2	005-2438	Washer copper 1/4"	2
3	008-2484	Nipple 1/4"	2
4	006-3389	Hose 2850 mm.; D90-060, 072, 088	1
5	006-3390	Hose 2550 mm.; D90-060, 072	1
	006-3389	Hose 2850 mm.; D90-088	1
6	008-2488	Nipple 1/4"-1/2"	2
7	003-6532	Washer copper 1/2"	2
8	004-1871	Quick connector 1/2"	2
9	006-3396	Rubber cap	2
10	006-3398	Hose sleeve	1

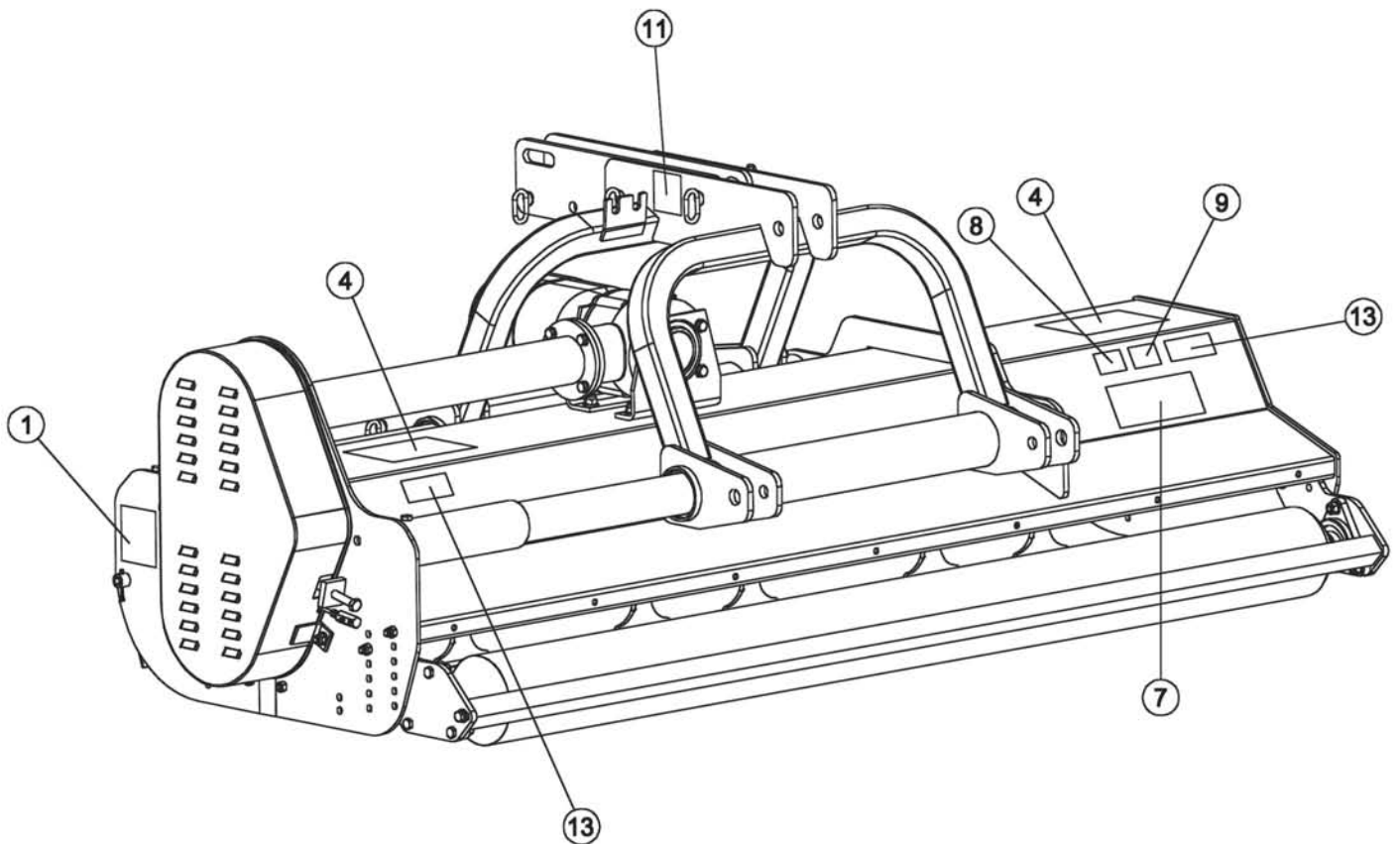
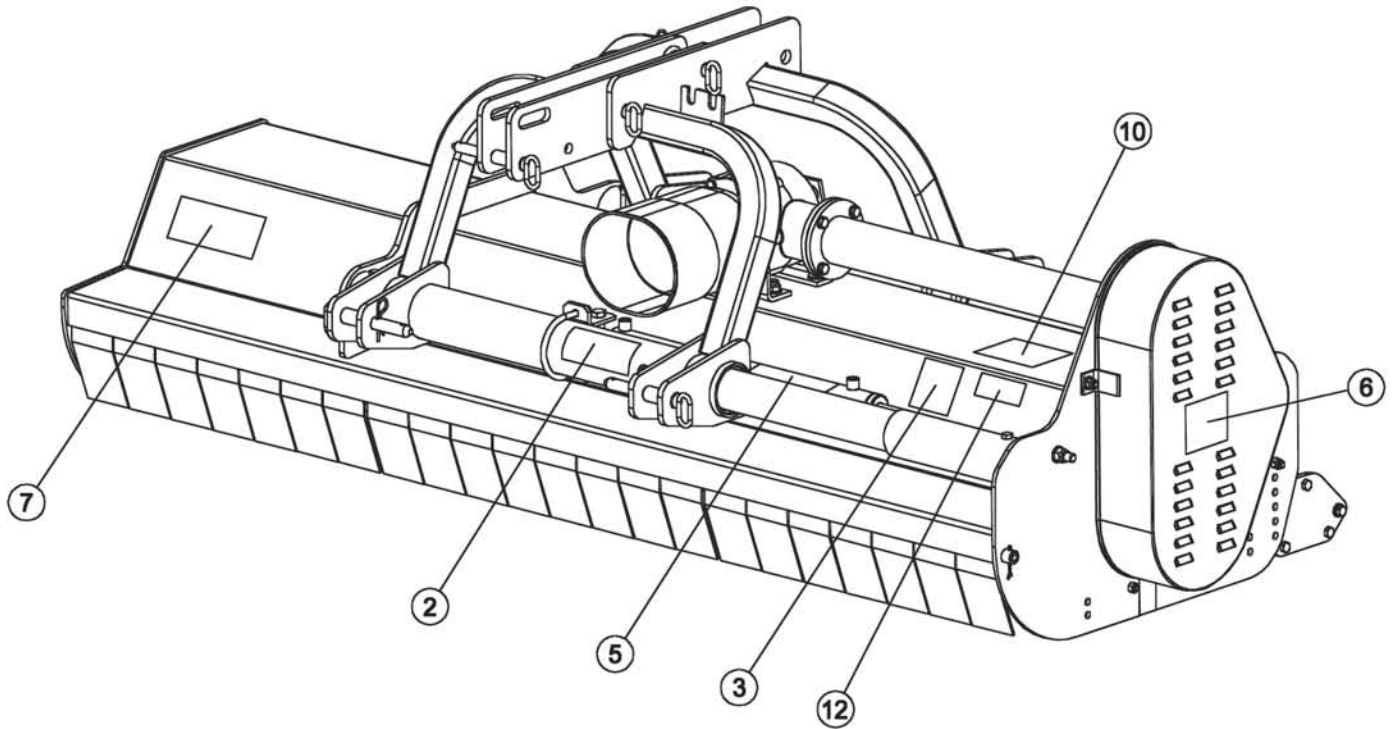

Ref.	Part #	Description	Qty.
1	950-486B	Decal "DANGER - Moving parts hazard"	1
2	950-109B	Decal "DANGER - Avoid injury from PTO"	1
3	950-111B	Decal "CAUTION - To avoid serious injury"	1
4	950-209B	Decal "DANGER - Rotating blades hazard"	2
5	950-408B	Decal "WARNING - High pressure hydraulic oil leaks"	1
6	950-103B	Decal "B"	1
7	950-107B	Decal "BEFCO"	2
8	950-495B	Decal "D90"	1
9	950-284B	Decal "060"	1
	950-285B	Decal "072"	1
	950-282B	Decal "088"	1
10	950-381B	Decal "BEFCO INC." address	1
11	950-940B	Decal "Quick Hitch Compatible"	1
12	950-405B	Yellow reflective decal	1
13	950-366B	Red reflective decal	2
	971-401B	Operator's & Parts Manual "Destroyer D90-060, 072, 088"	1

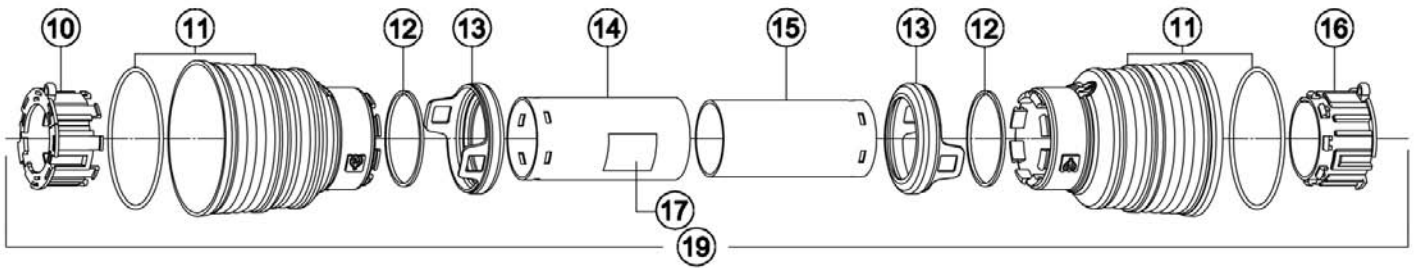
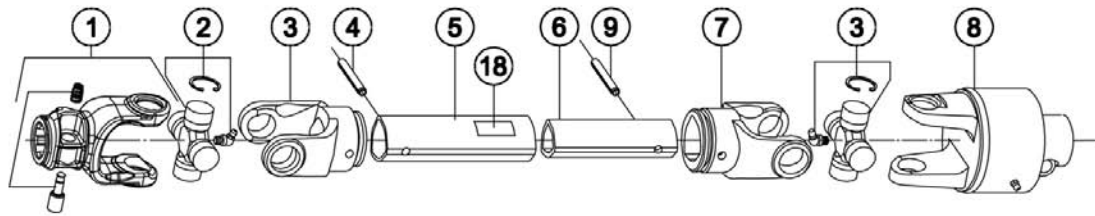

Ref.	Part #	Description	Qty.
1	1026010C	Yoke (tractor end)	1
2	1006020C	Cross & bearing	2
3	1706027C	Yoke, outer tube	1
4	003-2204	Roll pin Ø10x80	1
5	1528041C	Shaft, outer tube	1
6	1526041C	Shaft, inner tube	1
7	1706029C	Yoke, inner tube	1
8	1746260C	Overrunning clutch (implement end)	1
9	000-016E	Roll pin Ø10x70	1
10	1786710C	Locking ring, outer tube	1
11	1785703C	Standard cone	2
12	1215735C	Stop ring	2
13	1885709C	Safety sleeve	2
14	1776031C	Shield, outer tube	1
15	1877031C	Shield, inner tube	1
16	1786711C	Locking ring, inner tube	1
17	950-463B	Decal "DANGER - Rotating driveline, keep away" outer shield	1
18	950-464B	Decal "DANGER - Guard missing, do not operate" outer tube	1
19	90SS6031C	Shield, complete	1
20	1006065C	Chain, anti-rotation	2
	050-0471	Driveline w/overrunning clutch, complete	-

Use only original spare parts

All rights reserved. It is unlawful to copy, reprint or use any of the information or details in this manual without the expressed written permission of the Company. Technical information provided in this manual is approximate, the Company reserves the right to modify or improve the models shown for technical or commercial purposes. Pictures in this manual do not necessarily show the machine as delivered.

BEFCO[®]

P.O. Box 6036
Rocky Mount, NC 27802-6036
Tel.: 252.977.9920 - Fax: 252.977.9718
www.befco.com

