

# **BEFCO<sup>®</sup>**

## **Operator's Manual**

# **HAY EQUIPMENT**

**Rotary Tedders**

**DRO-330, DRP-330**

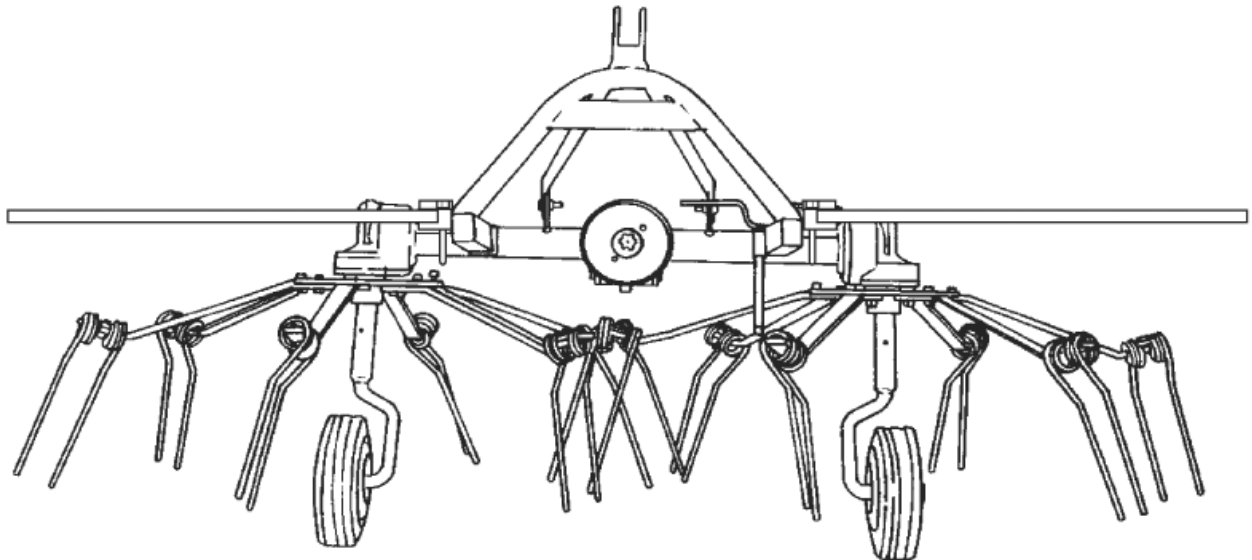

The operator's manual is a technical service guide and must always accompany the machine.

**Manual 960-390B**

**May 2010**

# SAFETY

Take note! This safety alert symbol found throughout this manual is used to call your attention to instructions involving your personal safety and the safety of others. Failure to follow these instructions can result in injury or death.



*This symbol means:  
ATTENTION!  
BECOME ALERT!  
YOUR SAFETY IS INVOLVED!*

## Signal Words

Note the use of the signal words DANGER, WARNING and CAUTION with the safety messages. The appropriate signal words for each have been selected using the following guidelines:



**DANGER:** Indicates an imminently hazardous situation that, if not avoided, will result in death or serious injury.



**WARNING:** Indicates a potentially hazardous situation that, if not avoided, could result in death or serious injury, and includes hazards that are exposed when guards are removed. It may also be used to alert against unsafe practices.



**CAUTION:** Indicates a potentially hazardous situation that, if not avoided, may result in minor or moderate injury.

# INDEX

<b>1 - GENERAL INFORMATION</b>	4
1.01 - General	4
1.02 - Model and Serial Number ID	5
<b>2 - SAFETY PRECAUTIONS</b>	6
2.01 - Preparation	6
2.02 - Starting and Stopping	7
2.03 - Messages and Signs	7
<b>3 - OPERATION</b>	10
3.01 - Operational Safety	10
3.02 - Set Up	12
3.03 - Assembly Instructions	12
3.04 - Pre-Operational Check	16
3.05 - Attaching to the Tractor	17
3.06 - Start Up	18
3.07 - Working Speed	19
3.08 - Operating Techniques	19
3.09 - Uneven Terrain	21
3.10 - Removing Tedder from the Tractor	22
3.11 - Transportation	22
<b>4 - MAINTENANCE</b>	25
4.01 - Maintenance Safety	25
4.02 - Service	26
4.03 - Driveline	26
4.04 - Ratchet Torque Limiter	28
<b>5 - REPAIR PROCEDURES</b>	30
5.01 - Rotor Timing	30
5.02 - Tine Replacement	30
5.03 - Suggested Spare Parts	31
5.04 - Storage	31
<b>6 - TROUBLESHOOTING</b>	32
<b>7 - PRE-DELIVERY CHECKLIST</b>	33
<b>8 - WARRANTY</b>	34
<b>PARTS MANUAL</b>	39

# 1 - GENERAL INFORMATION

Thank you and congratulations for having chosen our implement. Your new rotary tedder is a technologically advanced machine constructed of high quality, sturdy components that will fulfill your working expectations. Read this manual carefully. It will instruct you on how to operate and service your tedder safely and correctly. Failure to do so could result in personal injury and/or in equipment damage.

## 1.01 - General

The implement described in this manual is to be used with tractors with PTO at 540 rpm and clockwise rotation.



**CAUTION:** Always ensure that the coupling of the implement with the tractor is done at the same PTO speed and direction of rotation. Do not operate this implement at a PTO speed or direction of rotation other than that shown on the implement. Serious damage can occur to the machine and/or the operator.



**CAUTION:** Unless otherwise specified, all hardware is metric. Use only metric tools on metric hardware. Other tools that do not fit properly can slip and cause injury.



**CAUTION:** Right hand and left hand sides of the implement are determined by facing in the direction the implement will travel when going forward (see fig. 2).

Carefully read the Warranty section<sup>1</sup>, detailing coverage and limitations of this warranty. **Warranty** is provided for customers who operate and maintain their equipment as described in this manual. Warranty registration is accomplished by the dealer by completing and forwarding the **Warranty Registration** form to the Company, along with a copy of the dealer's invoice. It is in your best interest to insure that this has been done.

Warranty does not cover the following:

1. Cleaning, transporting, mailing and service call charges.
2. Normal wear items such as tines, bearings, drivelines, shear pins, slip clutches, etc.
3. Depreciation or damage caused by normal wear, accidents, improper maintenance, improper protection or improper use.
4. The use of non-original spare parts and accessories.

---

<sup>1</sup> See Chapter 8 - Warranty.

Your Authorized Company Dealer has genuine parts in stock. Only these approved replacement parts should be used.

This limited warranty covers defective material and workmanship. The cost of normal maintenance or repairs for accidents or improper use and related labor will be borne by the owner.

### 1.02 - Model and Serial Number ID

Attached to the frame is an ID plate showing the model and the serial number. Record your implement model and serial number in the space provided below. Your dealer needs this information to give you prompt, efficient service when you order parts.

<b>BEFCO</b>	1781 S. Wesleyan Blvd. – P.O. Box 6036 Rocky Mount, N.C. 27802 – U.S.A. Tel: 1.252.977.9920 Fax: 1.252.977.9718
<b>MODEL:</b>	<input type="text"/>
<b>SERIAL:</b>	<input type="text"/>
<b>VERSION:</b>	<input type="text"/>

## 2 - SAFETY PRECAUTIONS

Safety is the primary concern in the design and manufacture of our products. Unfortunately our efforts to provide safe equipment can be wiped out by a single careless act of an operator.

In addition to the design and configuration of equipment, hazard control and accident prevention are dependent upon the awareness, concern, prudence and proper training of personnel involved in the operation, transport, maintenance and storage of equipment. It is the operator's responsibility to read and understand all safety and operating instructions in the manual and to follow these.

Allow only properly trained personnel to operate the tedder. Working with unfamiliar equipment can lead to careless injuries. Read this manual, and the manual for your tractor, before assembly or operation, to acquaint yourself with the machines. It is the tedder owner's responsibility, if this machine is used by any person other than yourself, is loaned or rented, to make certain that the operator, prior to operating, reads and understands the operator's manuals and is instructed in safe and proper use.

### 2.01 - Preparation



1. Before operating equipment read and understand the operator's manual and the safety signs (**see fig. 2**).
2. Thoroughly inspect the implement before initial operation to assure that all packaging materials, i.e. wires, bands, and tape have been removed.
3. Personal protection equipment including hard hat, safety glasses, safety shoes, and gloves are recommended during assembly, installation, operation, adjustment, maintaining and/or repairing the implement.
4. Operate the tedder only with a tractor equipped with an approved Roll-Over-Protective-System (ROPS). Always wear your seat belt. Serious injury or even death could result from falling off the tractor.
5. Clear area of stones, branches or other debris that might be thrown, causing injury or damage.
6. Operate only in daylight or good artificial light.
7. Ensure tedder is properly mounted, adjusted and in good operating condition.
8. Ensure that all safety shielding and safety signs are properly installed and in good condition.

## 2.02 - Starting and Stopping



1. Be sure that no one is near the machine prior to engaging or while the machine is working.
2. Be sure the tractor is in "Neutral" before starting engine.
3. Tedder operating power is supplied from tractor PTO. Refer to your tractor manual for PTO engagement and disengagement instructions. Never operate PTO over 540 rpm. Know how to stop the tractor and tedder quickly in case of an emergency.
4. When engaging PTO, the engine rpm should always be low. Once engaged and ready to start, raise PTO speed and maintain throughout operation.
5. Check the tractor master shield over the PTO stub shaft. Make sure it is in good condition and fastened securely to the tractor. Purchase a new shield if old shield is damaged or missing.
6. After striking an obstacle, disengage the PTO, shut the tractor down and thoroughly inspect for damage before restarting.
7. Never engage the PTO until the tedder is in the down position and resting on the ground. Never raise the tedder until tines have come to a complete stop.
8. To park the vehicle safely, stop vehicle on a level surface (not on a slope), disengage PTO, engage the parking brake, stop the engine, remove the key, and wait for engine and all moving parts to stop before leaving the operator's seat.
9. Stay clear of rotating drivelines. Entanglement in rotating driveline can cause serious injury or death. Wear close fitting clothing. Stop the engine and be sure PTO driveline is stopped before getting near it.

## 2.03 - Messages and Signs



1. Read and adhere to all safety and operating decals on this machine (**see fig. 2**).
2. Before dismounting tractor: Allow moving parts to stop, stop engine, set brake and remove the key of unattended equipment.
3. Keep away from rotating tines and driveline.
4. Keep guards and shields in place and in good condition.
5. Do not operate unit with bystanders in area.
6. Allow no riders on tractor or tedder.
7. Allow moving parts to stop before repair.
8. Securely support tedder before working underneath.

Additional warning and operating decals are available at no extra charge. Please specify model and serial number when ordering.

Fig. 2 - Safety decals - implement; replace immediately if damaged.

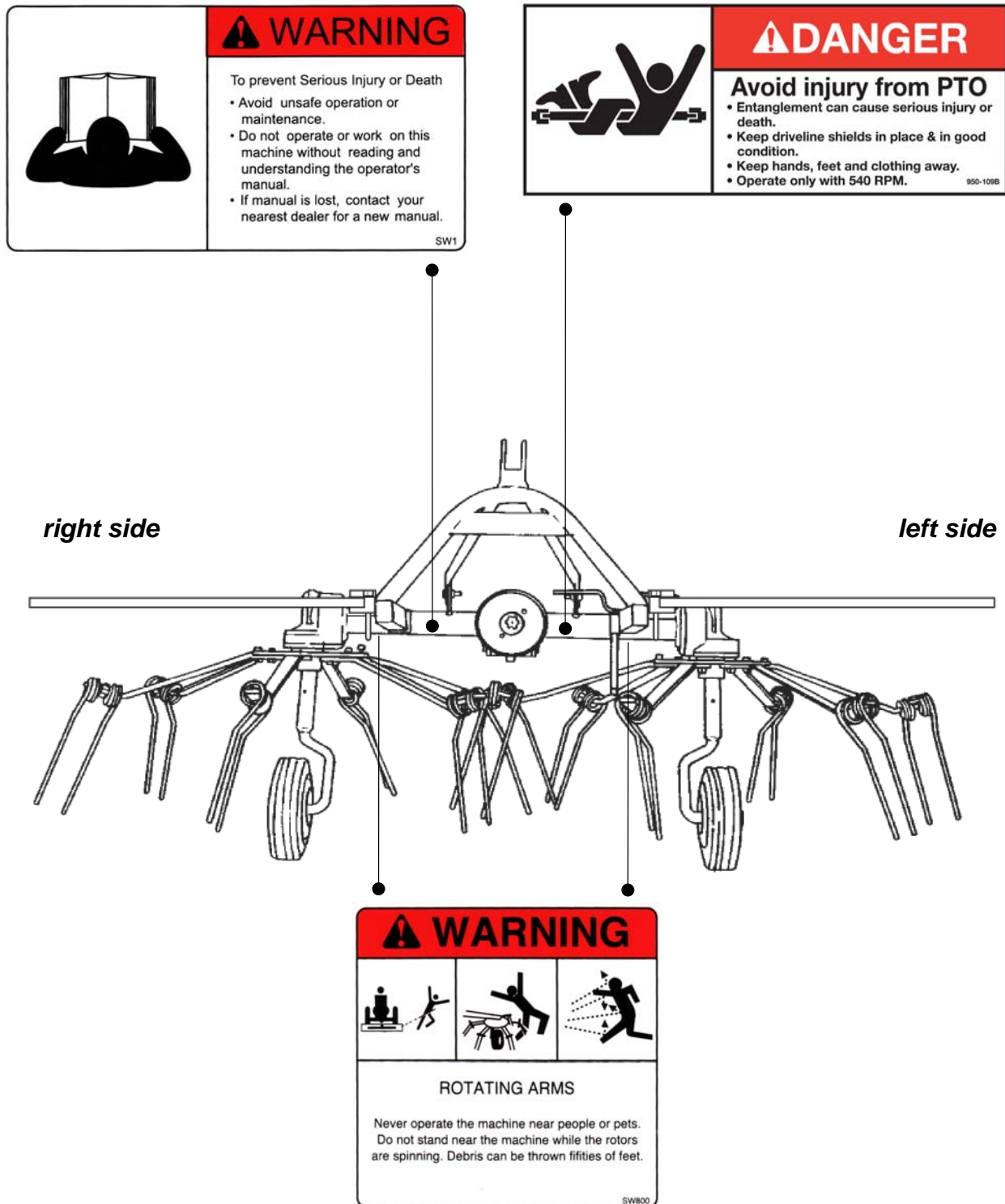



**Safety decals - driveline; replace immediately if damaged.**

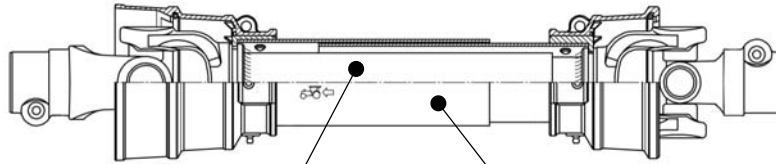

*placed on outer tube*



*placed on outer shield*

## 3 - OPERATION

BEFCO's rotary tedders are available with three point hitch or pull type configuration and have a working width of 11'. All tedders are 540 rpm PTO driven and suited for tractors from 20 to 50 HP. As the tedder advances the crop is thrown, separated and fluffed evenly and quickly by the wide radius rotors therefore reducing drying time. The rotors turn towards each other at the front forcing the crop to be moved between them and thrown to the rear of the machine. Each rotor carries large size tine arms and tough spring steel tines for faster ground speed. The tedder support wheels run close to the tines which allow the tines to follow the contour of the terrain and reduce the risk of them digging into the ground. Hay crops dry fast and evenly due to the fluffing action and the enhanced air movement produced by the machine.

### 3.01 - Operational Safety



**CAUTION:** Our tedders are designed considering safety as the most important aspect and are the safest available in today's market. Unfortunately, human carelessness can override the safety features built into our machines. Injury prevention and work safety, aside from the features on our tedders, are very much due to the responsible use of the equipment. It must always be operated prudently following with great care, the safety instructions laid out in this manual.



1. The use of this equipment is subject to certain hazards which cannot be prevented by mechanical means or product design. All operators of this equipment must read and understand this entire manual, paying particular attention to safety and operating instructions, prior to using.
2. Do not operate the tractor and tedder when you are tired, sick or when using medication.
3. Keep all helpers and bystanders at least 50 feet from a tedder. Only properly trained people should operate this machine.
4. The majority of accidents involve entanglements on the driveline, injury of bystanders by objects thrown by the rotating tines and operators being knocked off the tractor by low hanging limbs and then being run over by the tedder. Accidents are most likely to occur with machines that are loaned or rented to someone who has not read the operator's manual and is not familiar with a tedder.
5. Always stop the tractor, set brake, shut off the tractor engine, remove the ignition key, lower implement to the ground and allow tedder tines to come to a complete stop before dismounting tractor. Never leave equipment unattended with the tractor running.

6. Never place hands or feet near tedder with tractor engine running or before you are sure all motion has stopped. Stay clear of all moving parts.
7. Do not allow riders on the tedder or tractor at any time. There is no safe place for riders.
8. Do not operate unless all personnel, livestock and pets are at least 50 feet away to prevent injury by thrown objects.
9. Install and secure all guards and shields before starting or operating.
10. Keep hands, feet, hair and clothing away from moving parts.
11. These tedders are designed for use only on tractors with 540 rpm power take off.
12. Never operate tractor and tedder under trees with low hanging limbs. Operators can be knocked off the tractor and then run over by the rotating tines.
13. The rotating parts of this machine have been designed and tested for rugged use. However, they could fail upon impact with heavy, solid objects such as steel guard rails and concrete abutments. Such impact could cause the broken objects to be thrown outward at very high velocities. To reduce the possibility of property damage, serious injury, or even death, never allow the tedder tines to contact such obstacles.
14. Frequently check tedder tines. They should be securely fastened.
15. Stop tedder immediately upon striking an obstruction. Turn engine off, remove key, inspect and repair any damage before resuming operation.
16. Stay alert for holes, rocks and roots in the terrain and other hidden hazards. Keep away from drop-offs.
17. Use extreme care and maintain minimum ground speed when transporting on hillside, over rough ground and when operating close to ditches or fences. Be careful when turning sharp corners.
18. Reduce speed on slopes and sharp turns to minimize tipping or loss of control. Be careful when changing directions on slopes. Do not start or stop suddenly on slopes. Avoid operation on steep slopes.
19. When using a unit, a minimum 20% of tractor and equipment weight must be on tractor front wheels. Without this weight, tractor could tip over, causing personal injury or death. The weight may be attained with a front end loader, front wheel weights, ballast in tires or front tractor weights. When attaining a minimum 20% of tractor and equipment weight on the front wheels, you must not exceed the ROPS weight certification. Weigh the tractor and equipment. Do not guess or estimate!
20. Inspect the entire machine periodically<sup>2</sup>. Look for loose fasteners, worn or broken parts, and leaky or loose fittings.
21. Use only the driveline supplied with the tedder. Do not use it if it is missing any shield or safety protection.
22. Pass diagonally through sharp dips and avoid sharp drops to prevent "hanging up" tractor and tedder.
23. Avoid sudden starts and stops while traveling up or downhill.
24. Always work down slopes; never across the face. Avoid operation on steep slopes. Slow down on sharp turns and slopes to prevent tipping and/or loss of control.

---

<sup>2</sup> See Chapter 4 - Maintenance.

### 3.02 - Set Up

**Notice to dealer:** Pre-delivery setup and service including lubrication is the responsibility of the authorized dealer. It is up to him to assure that the machine is in perfect condition and ready to be used. It is his responsibility to ensure that the customer is aware of all safety aspects and operational procedures for the tedder. He must also fill out the Pre-Delivery Checklist<sup>3</sup> prior to delivering the tedder.

### 3.03 - Assembly Instructions

Each unit is shipped in a crate as a kit that consists of the following:		
Description	Model DRO-330 Qty.	Model DRP-330 Qty.
Main frame with gearbox and wheel spindles	1	1
Three point hitch carrier assembly	1	-
Pull type drawbar assembly	-	1
Support bar with hardware	-	1
Left tine arms with attached tines	6	6
Right tine arms with attached tines	6	6
Wheel Ø15x600-6	2	2
Driveline B2x1300 LW2	-	1
Driveline B2x1000 LW2	1	-
Guard support	2	2
Safety guard (attached before shipment)	2	2
<b>Hardware bag contains the following:</b>		
PTO protection guard	1	1
Hose clamp	1	1
Tine arm wrench	1	1
Outer wheel cover	2	2
Inner wheel cover	2	2
Nut M16 elastic stop	2	2
Knob for safety guard	4	4
Bolt M14x40	8	8
Bolt M14x25 socket head	4	4
Nut M14 elastic stop	12	12

Note: All hardware needed for assembly will be found in the crate, in the hardware bag or on the machine. Assembly will be easier if all parts are loosely assembled before tightening the hardware.



**CAUTION:** Stand clear of bands when cutting as they could be under sufficient tension to cause them to fly loose. Take care in removing bands and wire. They often have extremely sharp edges and cut very easily.

To assemble the machine proceed as follows:

Using a hoist, lift the machine approximately 6" from the ground to assemble the wheels. Place the inner cover, the wheel and the outer cover on the wheel shaft and tighten using the M16 elastic stop nuts (**see fig. 3**).

<sup>3</sup> See Chapter 7 - Pre-Delivery Checklist.

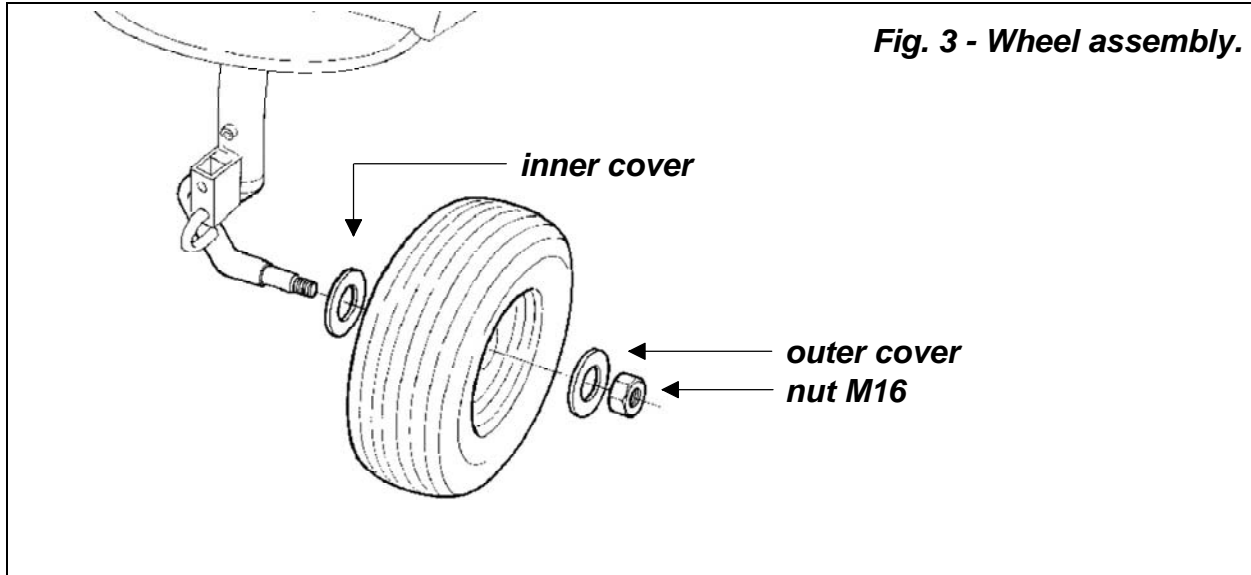

**Fig. 3 - Wheel assembly.**

On tedder model DRO-330, attach the three point hitch carrier assembly to the frame using two bolts M14x30 in the top brackets and two bolts M14x60 in the bottom brackets (**see fig. 4**). Tighten bolts using elastic stop nuts M14 then lay the machine on the ground.

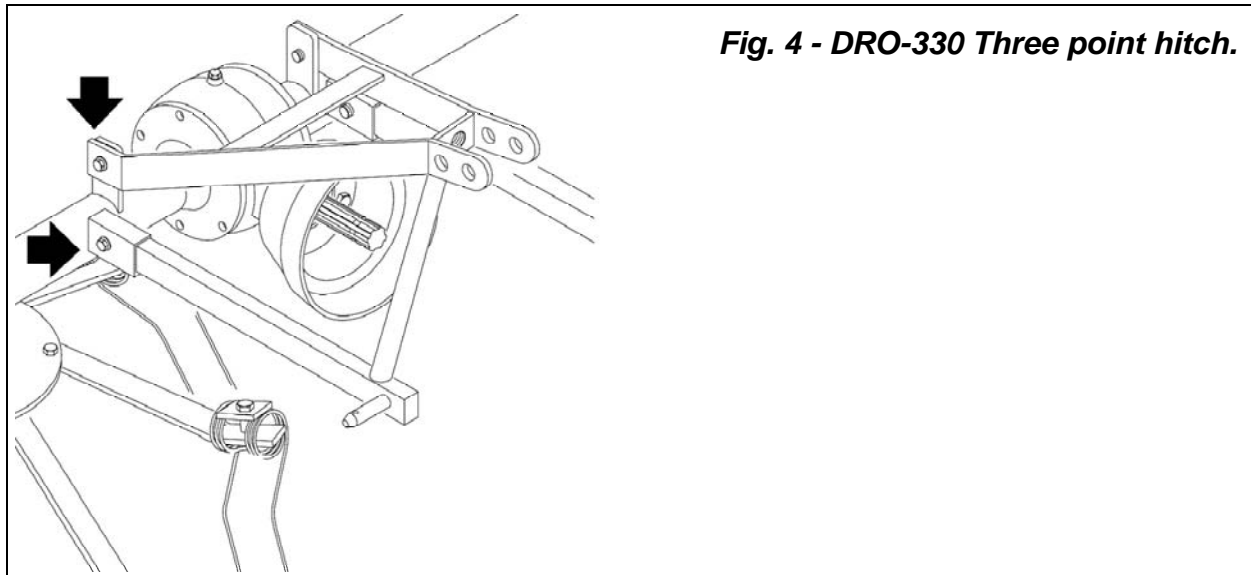

**Fig. 4 - DRO-330 Three point hitch.**

On tedder model DRP-330, assemble the pull type hitch by attaching the turnbuckle to the top hitch connecting point and securing it in place with the bolt M16x70 and the elastic stop nuts M16. Line up the lower hitch yokes with holes in the lower arm brackets, insert the bolts M14x90 and tighten them using the supplied elastic stop nuts M14.

Adjust the rotary tedder's working height by turning the handle on the turnbuckle until the tines are barely touching the ground (**see #1, fig. 5**).

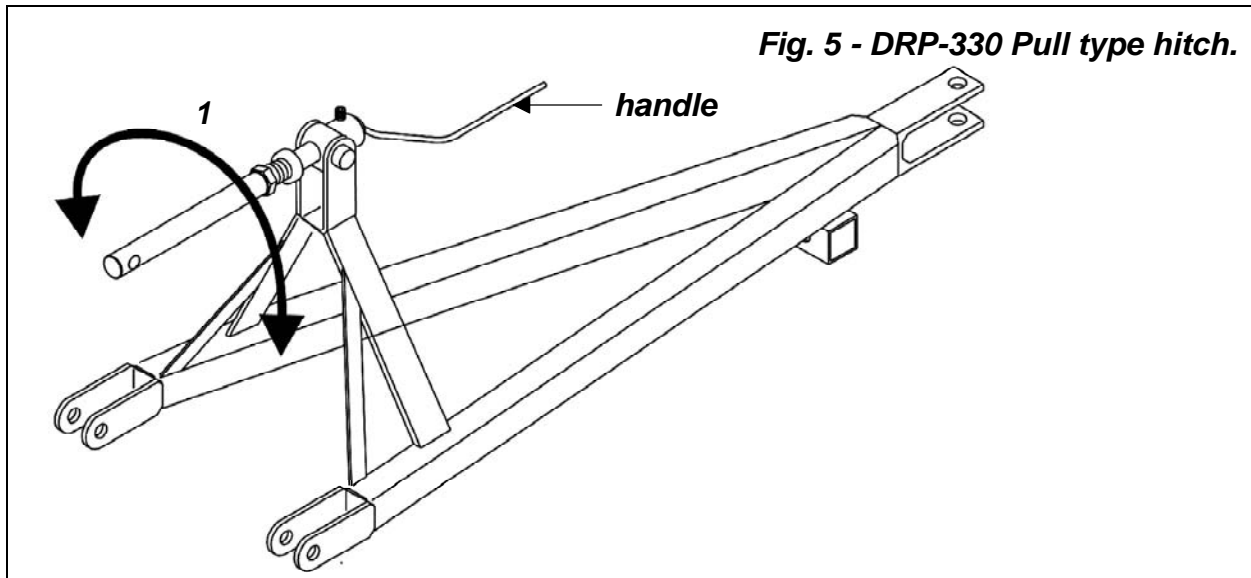

Inspect and grease all fittings on frame (see fig. 6).

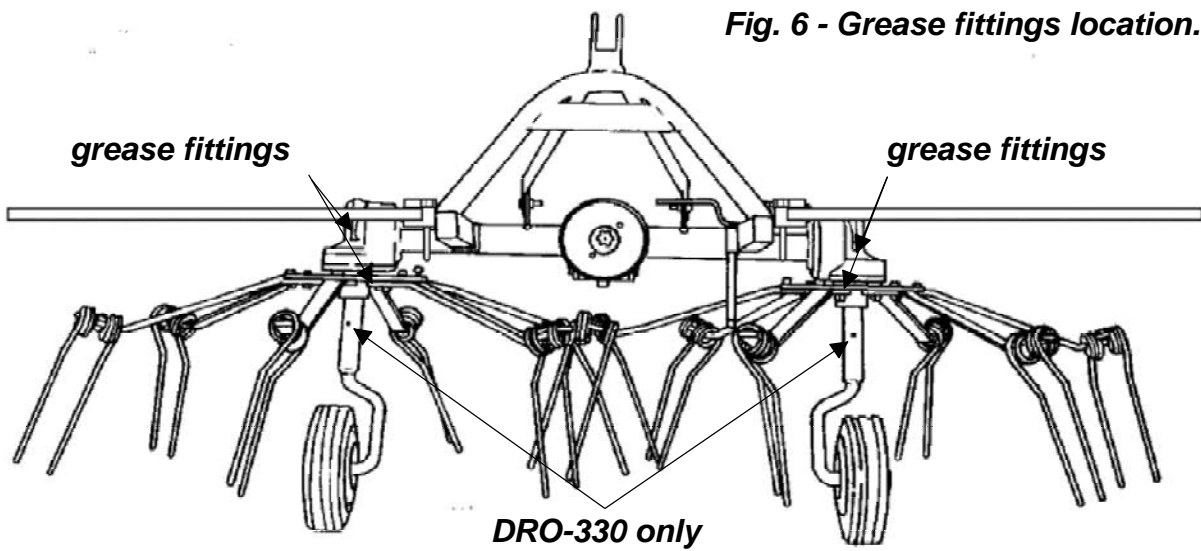

Install PTO protection guard over gearbox output shaft using the supplied hose clamp (see fig. 7).

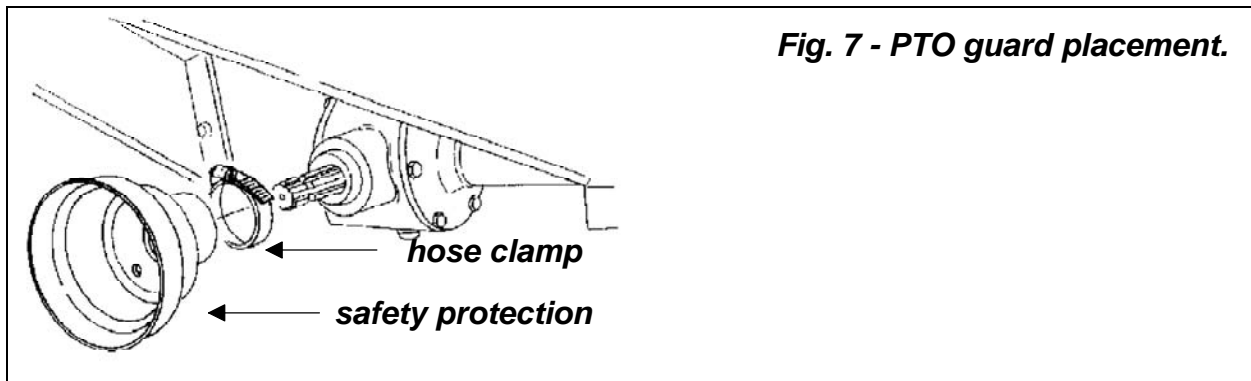

The tine arms are separated in two bundles (left and right). Separate the tine arms and determine which are right and which are left. This is done by holding the tine arm with the tine away from you. A right tine arm will have the tine bending to the right then pointing straight down, while a left tine arm will have the bend going towards the left then down. Looking at the machine from the rear, place the right hand tine arms next to the right rotor and the left hand tine arms next to the left rotor (**see fig. 8**).

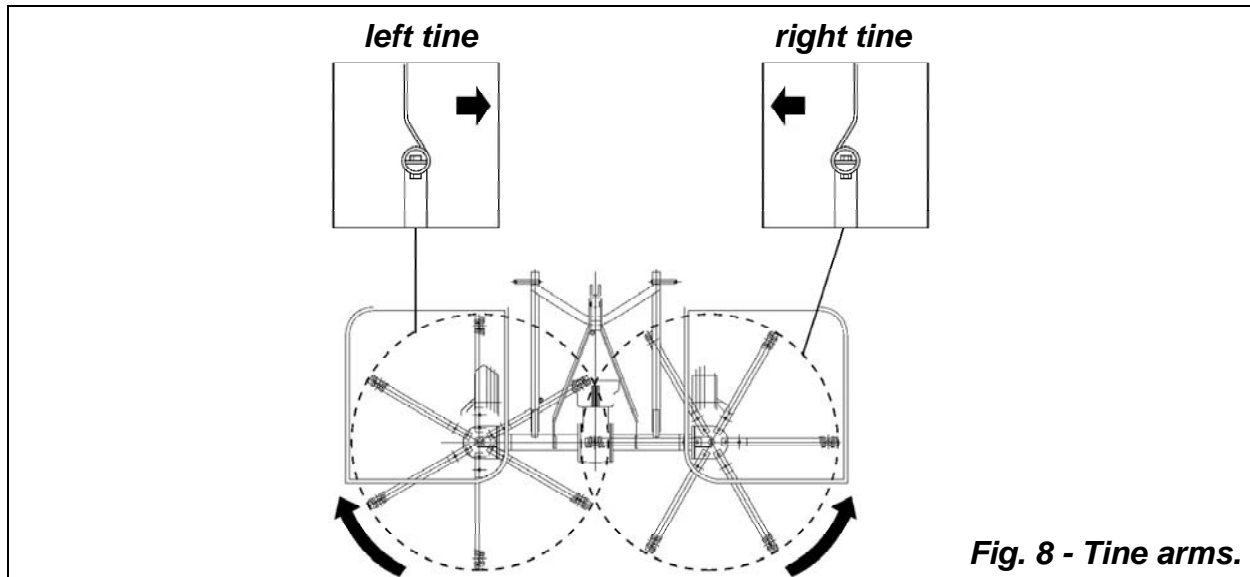

**Fig. 8 - Tine arms.**

There are two adjustable tine arms per rotor with threaded holes and four fixed arms with a welded pin on each arm. Install the four fixed tine arms using the M14x40 bolts and the M14 elastic stop nuts. Place the welded pin at the end of the tine arm in the inside hole on the bottom of the rotor flange. With a rubber mallet, hammer the tine arm until it is flush against the bottom of the rotor flange (**see fig. 9**).

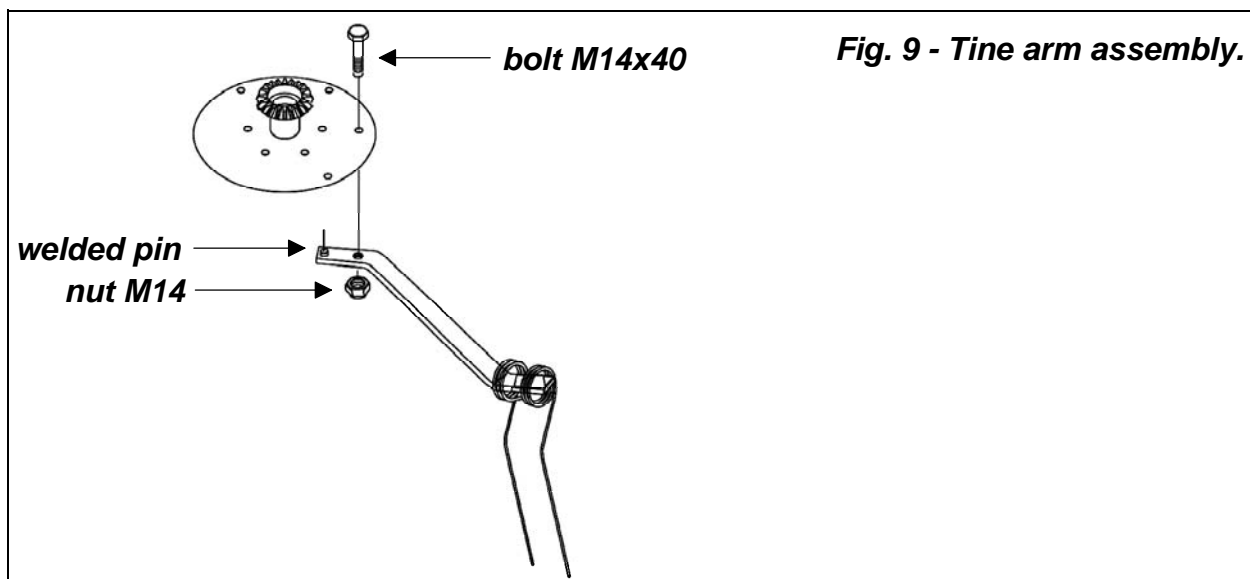

**Fig. 9 - Tine arm assembly.**

Install the two adjustable tine arms using M14x40 bolts and M14 nuts in the inner holes of the tine arms and M14x25 socket head bolts in the outer holes.

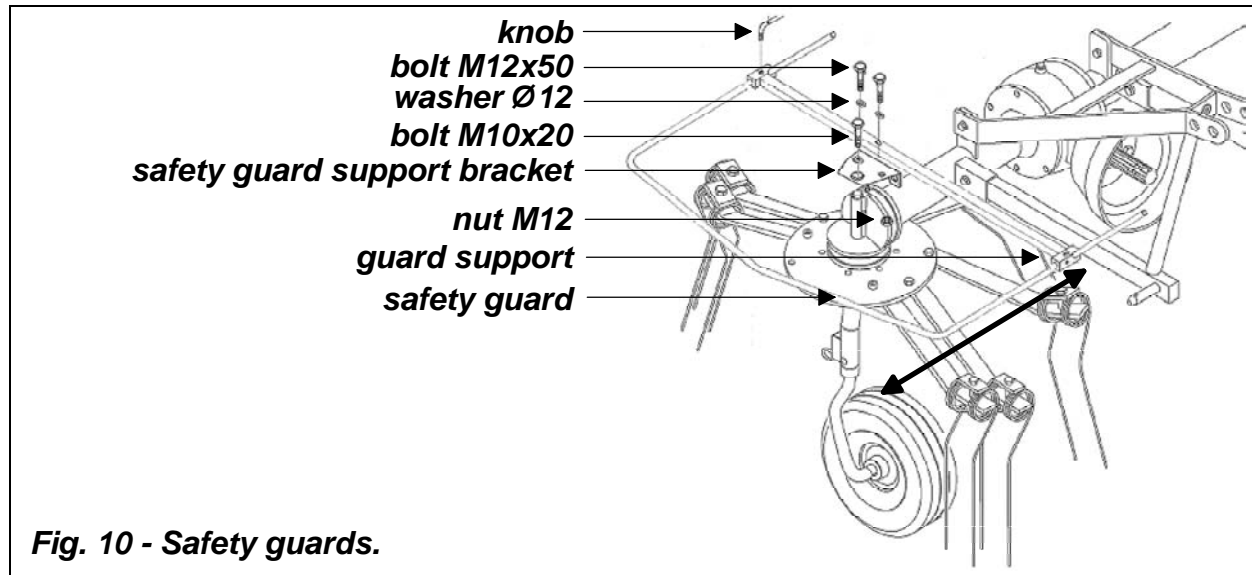

**Fig. 10 - Safety guards.**

Assemble the left and right safety guards delivered with the machine (**see fig. 10**). Bolt on the guard supports over the safety guard support brackets using the supplied bolts and washers. Insert the safety guards through the holes on each end of the guard supports and lock them in place using the knobs.

Safety guards need to be kept in the fully extended position while the unit is in operation. Guards can be retracted for transport and storage purposes only.



**CAUTION:** Always keep safety guards in extended position while unit is in operation.

### 3.04 - Pre-Operational Check

**IMPORTANT:** Check each of the following, carefully, prior to engaging the equipment:

1. The rotor bearings have been greased.
2. The oil in the gearbox.
3. The driveline cross and bearings have been greased.
4. No wrappings or foreign objects are around the tines or rotor flanges.
5. The tines are properly installed, the tine bolts properly torqued<sup>4</sup> and the timing is correct.
6. All hardware is tight.
7. The tractor, to ensure correct direction of PTO and rpm speed.
8. All safety shields and guards are in place and tightly attached.
9. No people or animals are in the work area.

<sup>4</sup> See Table 1, page 29.





**DANGER:** Stay clear of rotating driveline. Entanglement in rotating driveline can cause serious injury. Disengage PTO, engage parking brake or place transmission in “Park”, shut off the tractor and remove the key before working around hitch, attaching or detaching driveline, making adjustments, servicing or cleaning the machine.

### 3.05 - Attaching to the Tractor

Unit may be used on tractors ranging from 20 to 50 HP equipped with a standard PTO and category 1 three point hitch<sup>5</sup>. **Never use this tedder with tractors over 50 HP.**



**CAUTION:** Check the tractor PTO rpm to ensure it is set at 540 and turns clockwise.



**CAUTION:** Never attempt to attach the tedder to the tractor or make any adjustments to it without first turning the tractor off.



**DANGER:** Failure to ensure a secure coupling of the implement to the tractor can cause injury and damage to the implement or tractor. If necessary, wheel weights, front tractor weights and/or tire ballast should be used to improve stability. Be sure that the tractor tire pressure is correct. It is important to strictly follow the safety guidelines and instructions laid out in the tractor's operator's manual.

**To attach the tedder to the tractor do the following:**

1. On tedder model DRO-330, back the tractor up to the tedder in order to slip the tractor hitch arms over the hitch pins on the tedder hitch arms. **Turn off the tractor engine.** Secure them in place with the lynch pins. Adjust the tractor sway blocks or chains to remove all side movement. Attach the top link. Make sure wheel locks are disengaged before operating the machine (**see fig. 15**).
2. On tedder model DRP-330, position the tractor drawbar (**see fig. 11**). Remove the hitch pin. Align hitch pin holes in tractor drawbar and tedder. Install hitch pin and fasten it with a cotter pin.
3. Install the shielded driveline to the tractor by first lining up the splines and depressing the snap pin. Push the yoke onto the PTO shaft as far as it will go. Release the pin and pull back slowly until the pin clicks in place. Repeat this operation on the implement end. Be sure to install the ratchet torque limiter side of the PTO shaft on the implement.

<sup>5</sup> See Table 2, page 29.

4. Attach the driveline chains to the tractor and to the tedder to keep the driveline protection from turning. The chains should not be too tight.
5. Ensure the driveline has at least 2" from bottoming out in its shortest working position and has the minimum 6" overlap in its longest working position. Refer to **Section 4.03<sup>6</sup>** of this manual, if it is determined that the driveline is too long and needs to be shortened. Contact your local dealer if it is determined that the driveline is too short for your tractor.

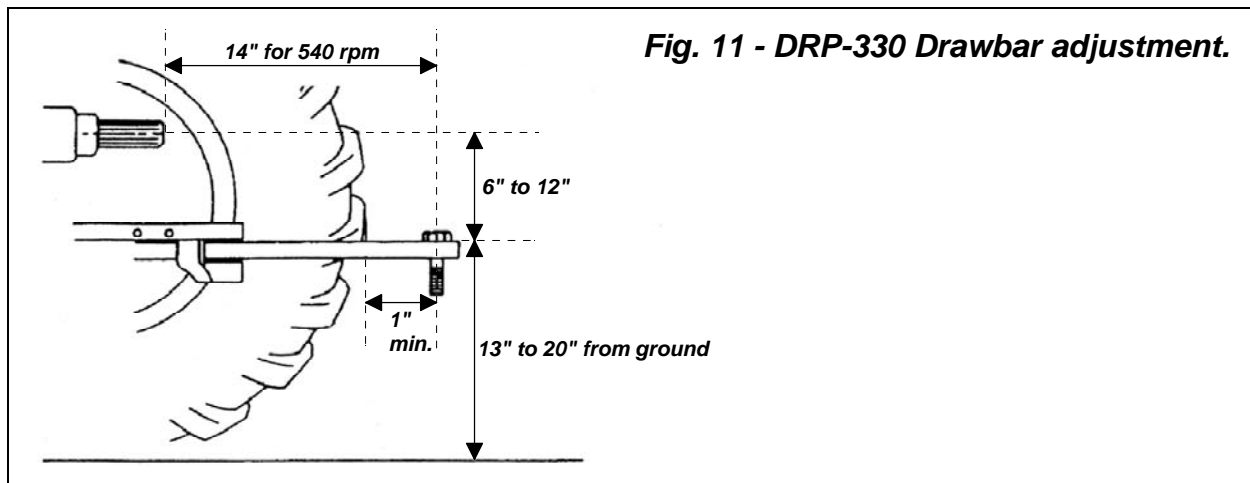

On pull type tedder model DRP-330, always make sure to adjust the tractor drawbar as specified to ASAE standards to prevent failures (**see fig. 11**). An improperly set hitch could subject the driveline's universal joints to undue stress. The drawbar should be centered under the PTO shaft and secured so it cannot swing in either direction.



**CAUTION:** Failure to conform to ASAE standards for drawbar PTO setup dimensions can result in driveline damage and implement failure.

### 3.06 - Start Up



**DANGER:** The tedder must always be lowered to the ground before starting tractor engine or engaging PTO lever.

Lower tedder to the ground. With the engine idling, slowly engage the PTO drive. Move the throttle lever until the PTO speed indicated on the tedder is obtained. PTO speed may vary from 400 rpm to 540 rpm. Never exceed 540 rpm.

<sup>6</sup> See Section 4.03 - Driveline, for instructions on how to determine correct driveline length and procedures for shortening the driveline.

Shift the transmission to a slow speed gear and start forward, increase the ground speed by shifting upward until the desired speed is obtained.



**CAUTION: Do not operate this tedder at a PTO speed or direction of rotation other than that shown on the tedder. Serious damage can occur to the machine and/or the operator.**

Before starting work, never forget that the **operator is responsible** for the following:

1. Safe and correct driving of the tractor and tedder.
2. To learn precise safe operating procedures for both the tractor and the tedder.
3. To ensure all maintenance and lubrication has been performed on the tedder.
4. To have read and understood all safety aspects for the tedder in the operator's manual.
5. To have read and understood all safety decals on the tedder.
6. Checking the condition of the tines. Worn or damaged tines should be changed before starting.
7. Checking that there is no wire, weed, grass or other material wrapped around rotors or tines.
8. Checking to see if front weights need to be added to the tractor in order to maintain balance.
9. Checking the tractor tires for the proper pressure in accordance with the tractor's operator's manual.
- 10. Checking that the PTO shield and all other shielding are on the machine and securely in place.**
11. Making sure the proper attire is worn. Avoiding loose fitting clothing which can become entangled. Wearing sturdy, tough-soled work shoes and protective equipment for eyes, hands, ears and head. Never operate tractor or implements in bare feet, sandals or sneakers.
12. Checking area for stones, branches and other debris that might be thrown.
13. Ensuring proper lighting is available, sunlight or good artificial lighting.

### **3.07 - Working Speed**

The working speed depends on ground conditions, tractor horsepower, type of forage crop, crop density and humidity. Only a test run will enable you to gauge the optimal working speed for your conditions. Under most conditions a 5 to 7 mph ground speed is best. A slower speed may be necessary on hills or rough terrain.

### **3.08 - Operating Techniques**

Rotary tedders perform best when the clearance between the ground and the bottom of the front tines is set to approximately 1" to 2" (**see fig. 12**). The conditions of the field will ultimately determine how you can set the tines to the ground. The flatter the field the higher the tines can be set from the ground. To achieve the best results it is important to

set the tines as high as possible in order to limit contact of the tines with the ground. This not only prolongs tines' life but will also keep dust and soil off the hay.

**Fig. 12 - Adjusting the tedder.**

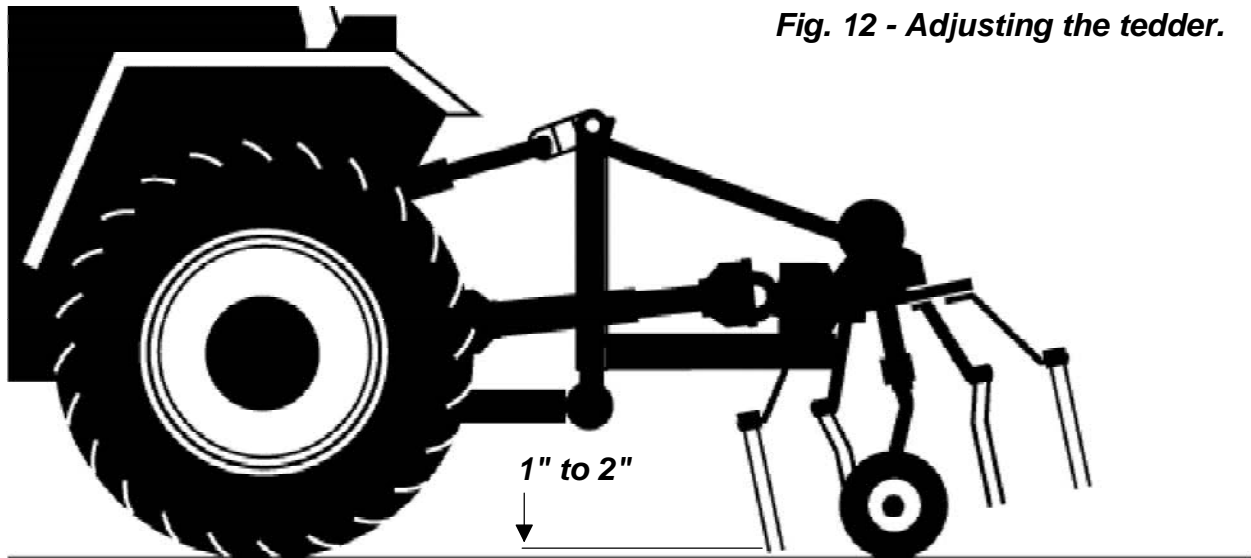

On pull type tedder model DRP-330, the tine height adjustment is made by turning the handle positioned on top of the gearbox (see #1, fig. 5). Turning the handle clockwise will raise the height while turning the handle counterclockwise will lower it.

On three point tedder model DRO-330, the height adjustment is made through the tractor's three point hitch. Raising the hitch will tilt the machine backwards therefore raise the front tines; while lowering the hitch will tilt the machine forward and therefore lower the front tines. Always remember to raise three point tedder when turning sharp corners or damage to the wheels or spindles may occur.

**Fig. 13 - Operating the tedder.**

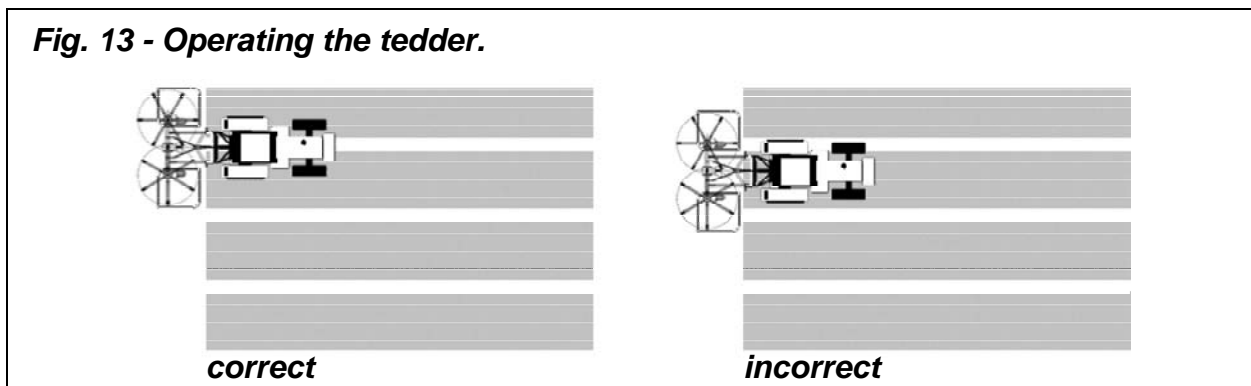

To adequately pick up and spread windrows it may be better to operate tedder with the windrows directly in front of the rotors rather than with the windrows between the rotors (see fig. 13).

If the crop was mowed with a sickle bar mower, operate the tedder in the same direction the crop was mowed, while if the crop was mowed with a rotary mower, best results are obtained by operating tedder in the opposite direction the crop was mowed.

The crop spread pattern is determined by a combination of crop density, rotor speed and ground speed.

If possible, it is advisable to start work around the perimeter of the field and then work the interior of the field back and forth (**see fig. 14**). This will reduce maneuvering time and ensure that no crop is left unturned.

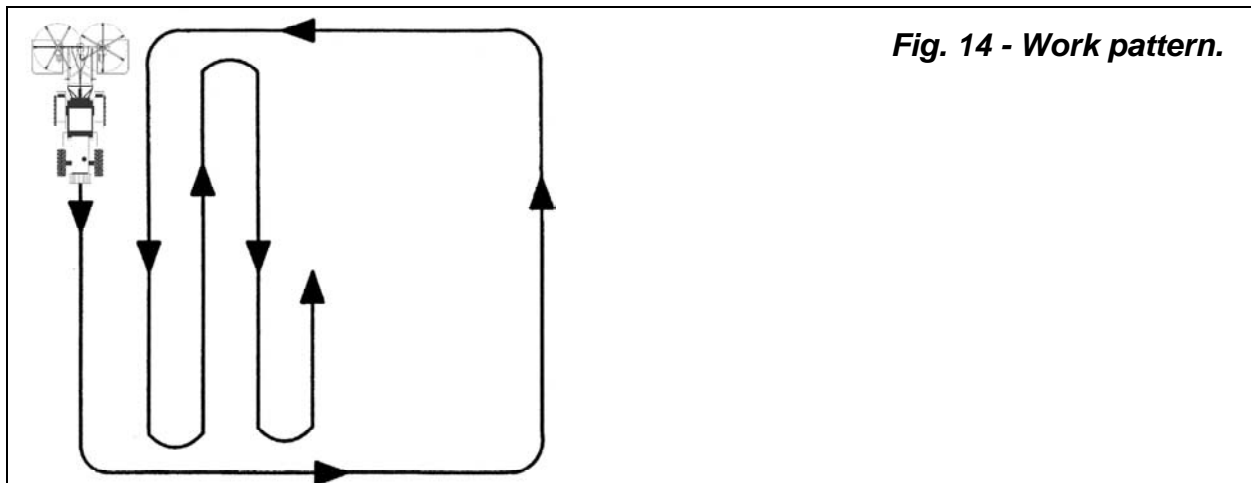

**Fig. 14 - Work pattern.**



**DANGER:** Never operate the tedder without first ensuring that all protective devices are properly installed.



**WARNING:** Tedder tines can throw objects which could result in personal injury or property damage. Pick up all rocks and other debris before operating unit. Enter new areas carefully.



**CAUTION:** For emergency reasons learn how to stop the tractor and tedder quickly. On the tedder always disengage the PTO, lock parking brake, stop engine and allow the tedder tines to come to a complete stop before dismounting the tractor.

### 3.09 - Uneven Terrain



**DANGER:** Be careful of rollover when operating tractor and tedder over uneven ground.

The following precautions should always be observed when working on uneven terrain:

1. In extremely uneven terrain rear wheel weights, front tractor weights, and/or tire ballast should be used to improve stability.

2. Observe the type of terrain and develop a safe working pattern.
3. Whenever traction or stability is doubtful, first test drive over the terrain with the PTO disengaged.
4. Operate the implement up and down steep slopes, not across slopes, to prevent the tractor from tipping. Avoid sudden stops and starts, and slow down before changing directions on a slope.
5. Pass diagonally through sharp dips and avoid sharp drops to prevent hanging up the tractor and implement.
6. Slow down on sharp turns and slopes to prevent tipping or loss of control.
7. Watch for holes, roots or other hidden objects.
8. Do not use near the edge of a gully, ditch or stream bank.

### 3.10 - Removing Tedder from the Tractor



**CAUTION:** Disengage tractor PTO. Set parking brake. Stop engine and remove key from ignition. Disconnect tedder driveline from tractor PTO shaft. Collapse driveline and store in appropriate place. Disconnect three point linkage or pull type drawbar and carefully drive tractor away from tedder.

1. Park tedder on level and solid ground.
2. Disengage the tractor's PTO and make sure all parts have come to a complete stop.
3. Set parking brake and place transmission in "Park".
4. Stop engine and remove key from ignition.
5. Disconnect tedder driveline from tractor PTO shaft.
6. On tedder model DRO-330, disconnect three point linkage and carefully drive tractor away from tedder.
7. On tedder model DRP-330, remove the hitch pin and carefully drive tractor away from tedder.

### 3.11 - Transportation



**CAUTION:** Make sure PTO is disengaged and tedder tines have stopped turning before transporting tedder. Do not tow tractor and tedder behind other vehicles. Use a properly equipped trailer with heavy tie-downs for towing operations.



**CAUTION:** A safety chain will help control drawn equipment should it accidentally separate from the tractor drawbar. A runaway machine could cause severe injury or death. Leave only enough slack in the chain to permit turning. Do not use safety chain for towing.

Before transporting:

1. Always select a safe ground speed that is appropriate for the terrain.
2. Beware of traffic on public roads. Install a SMV (Slow Moving Vehicle) sign when traveling on roads or streets. Comply with all federal, state and local laws.
3. Reduce ground speed when turning and take care that the implement does not strike obstacles such as trees, fences or buildings.
4. Always disengage PTO before raising the implement to transport position.
5. When raising the implement be sure the PTO driveline does not hit either the tedder or the tractor.
6. During transport the tedder should not be lifted over 14"-16" from the ground.
7. On pull type tedder DRP-330, raise the tines before transporting unit. This is done by turning the handle positioned on top of the gearbox (**see #1, fig. 5**) clockwise until there is plenty of clearance between the tines and the ground. Install a safety chain (not supplied with unit) between tractor and implement before pulling the tedder down the road. A safety chain will help control drawn equipment should it accidentally separate from the tractor drawbar. Leave only enough slack in chain to permit turning.
8. On three point tedder DRO-330, block the wheels from pivoting using the lever on the wheel shaft (**see #1, fig. 15**).

**IMPORTANT:** Do not engage PTO while tedder is in the transport position. Severe damage to the tines, transmission and driveline will occur.

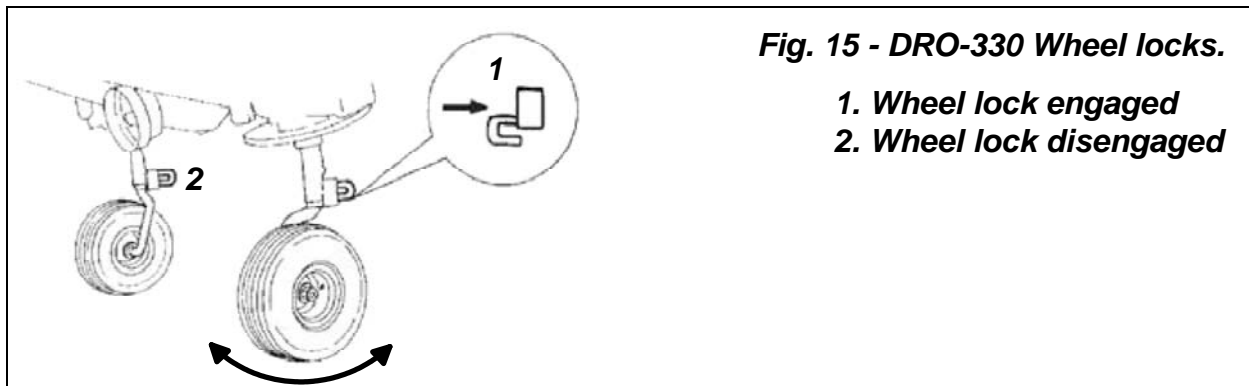
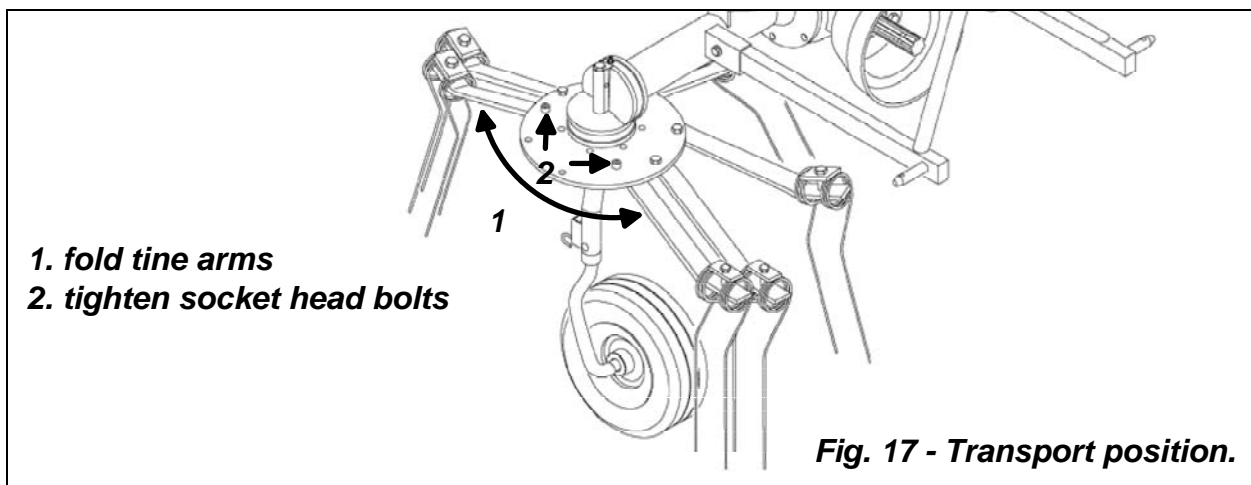
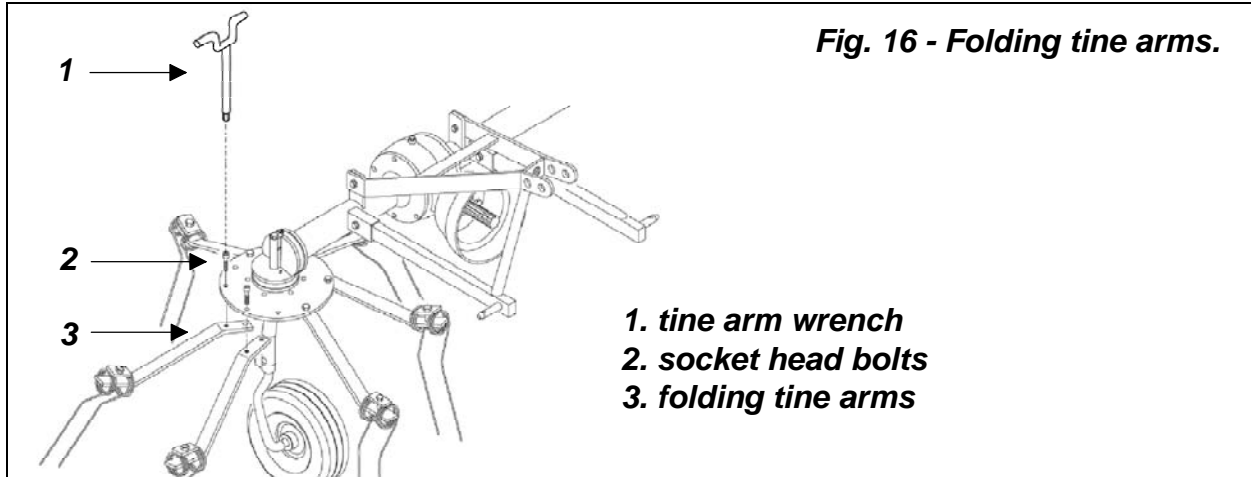

**Fig. 15 - DRO-330 Wheel locks.**

- 1. Wheel lock engaged**
- 2. Wheel lock disengaged**

DRO-330 and DRP-330 tedders are equipped with folding tine arms to allow for easier transportation down roads or through tight spots. Folding the tine arms will reduce the width of the unit from 11' in its typical working condition to approximately 6.5'.

To fold the two outer tine arms on each rotor, remove the two socket head bolts (**see #2, fig. 16**) using the supplied tine arm wrench (**see #1, fig. 16**). Turn the front arm forward and the back arm backward until they fit into the next hole on the flange then secure them in place with the socket head bolts (**see #2, fig. 17**). Insert the tine arm wrench in the welded tube on the frame, this will lock the tine arms in place and prevent them from turning while transporting the unit. Finally, loosen the two knobs on each safety guard and push the safety guards inwards then tighten knobs (**see fig. 10**).



If it is necessary to load the tedders on a truck to transport for long distances, tighten a strap around either side of the gearbox before attempting to raise the unit (**see fig. 18**). Slowly raise the unit to make sure the weight is balanced correctly.

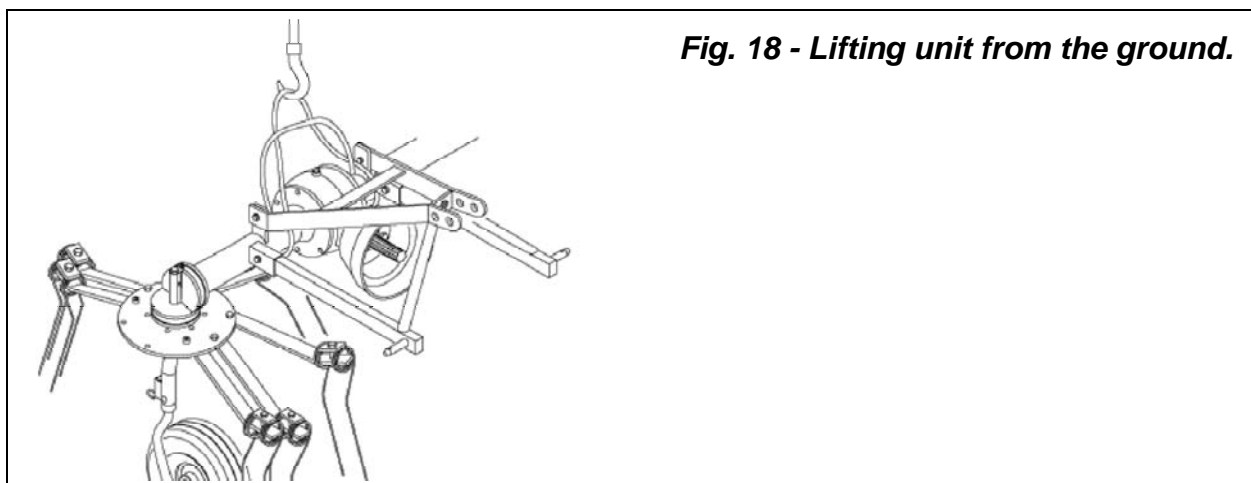



## 4 - MAINTENANCE



**DANGER: Stop engine, lock parking brake and remove key before performing any service or maintenance.**

**Never rely on the tractor lift system. Install blocks or stands under the implement to prevent it from falling.**

**Always use personal protection devices, such as glasses or gloves when performing maintenance.**

**Keep fingers out of slots to prevent injury.**

### 4.01 - Maintenance Safety



1. Good maintenance is your responsibility.
2. Keep service area clean and dry. Be sure electrical outlets and tools are properly grounded. Use adequate light for the job at hand.
3. Make sure there is plenty of ventilation. Never operate the engine of the towing vehicle in a closed building. The exhaust fumes may cause asphyxiation.
4. Make no repair or adjustments with the tractor engine running. Before working on the machine, disengage the PTO, shut off the engine, set the brakes, and remove the ignition key.
5. Be certain all moving parts on attachment have come to a complete stop before attempting to perform maintenance.
6. Never work under equipment unless it is blocked securely.
7. Always use personal protection devices such as eye, hand and hearing protectors, when performing any service or maintenance.
8. Periodically tighten all bolts, nuts and screws and check that all cotter pins are properly installed to ensure unit is in a safe condition.
9. When completing a maintenance or service function, make sure all safety shields and devices are installed before placing unit in service.
10. After servicing, be sure all tools, parts and service equipment are removed.
11. Never replace hex bolts with less than grade five bolts unless otherwise specified, i.e. shear bolts<sup>7</sup>.
12. Where replacement parts are necessary for periodic maintenance and servicing, genuine replacement parts must be used to restore your equipment to original specifications. The company will not claim responsibility for use of unapproved parts and/or accessories and other damages as a result of their use.

---

<sup>7</sup> Refer to Table 1 - Torque Specifications, page 29.

13. Unauthorized modifications to the machine may impair the function and/or safety of the machine and reduce its life. If equipment has been altered in any way from original design, the manufacturer does not accept any liability for injury or warranty.

## 4.02 - Service

The accompanying illustrations show lubrication points. The chart gives the frequency of lubrication in hours, based on normal operating conditions. Severe or unusual conditions may require more frequent lubrication.

Use a good quality SAE multipurpose type grease for all locations shown. Be sure to clean fittings thoroughly before using grease gun.

Use 90 wt. or 140 wt. gear oil in gearbox.

**IMPORTANT:** Check hardware tightness on the tines, tine arm connections to the rotors and safety guards after the first two, five and ten hours of operation. As these components set in with use the attaching bolts may loosen.

### Hourly or whenever an obstacle is hit:

1. Check the conditions of the tines, joints, rotors and gearboxes.

### Every 8 hours:

1. Lubricate driveline: Apply two or three shots of grease to the driveline cross and bearings and the telescoping shafts. See the driveline manufacturer operator's manual for further information on the driveline.
2. Check hardware tightness: Tedder vibration can loosen bolts<sup>8</sup>.
3. Lubricate threaded rod on height adjustment lever (model DRP-330 only).
4. Check gearbox oil level: It should be between  $\frac{1}{2}$  and  $\frac{2}{3}$  full. If needed add either SAE 90 wt. or SAE 140 wt. gear oil.

### Every 25 hours:

1. Lubricate rotor gearboxes.
2. Lubricate wheel spindles.
3. Check tire pressure. If necessary inflate tires to 25 psi.

## 4.03 - Driveline



**DANGER:** Only use the original driveline supplied with this tedder and always with the safety shielding.

Carefully read and file away the driveline operator's manual supplied by the manufacturer. The following does not substitute the information found in the driveline manual.

---

<sup>8</sup> See Table 1, page 29.

**IMPORTANT:** Always check driveline length during initial setup and when connecting to a different tractor.

In the collapsed position the driveline should be approximately 2" from bottoming out to prevent possible damage to the tractor or implement. When the driveline is in the maximum extended position, the ideal minimum overlap of the two halves should be approximately 6" (see fig. 19).

If determined that the driveline is too long, follow these procedures to adjust the length:

1. Separate the two driveline halves. Connect one half to the tractor PTO and the other half to the tedder.
2. On tedder DRO-330, raise and lower the tedder with the 3 point hitch to find the position where the driveline is shortest. Hold the half shafts side by side and mark the desired length on the outer female tube guard leaving a 1½" gap between the end of the guard tube and bell guard.
3. Cut off both guard tubes the same amount as marked in step 2.
4. Shorten both drive tubes the same amount as guard tubes.
5. De-burr and clean filings from drive tubes and apply grease to outside of inner telescoping tube.
6. Reassemble the driveline halves and connect to tractor and tedder. Raise and lower tedder again to be sure driveline does not bottom out in its shortest position and has a minimum overlap of 6" in the longest position.
7. Install both driveline safety chains. One should be hooked in a hole on the outer driveline yoke shield and to the tractor to restrict outer shield rotation. The second one should be hooked in a hole on the inner driveline yoke shield and to the implement to restrict inner shield rotation.

If determined that the driveline is too short for your tractor, contact your local dealer.

**Fig. 19**

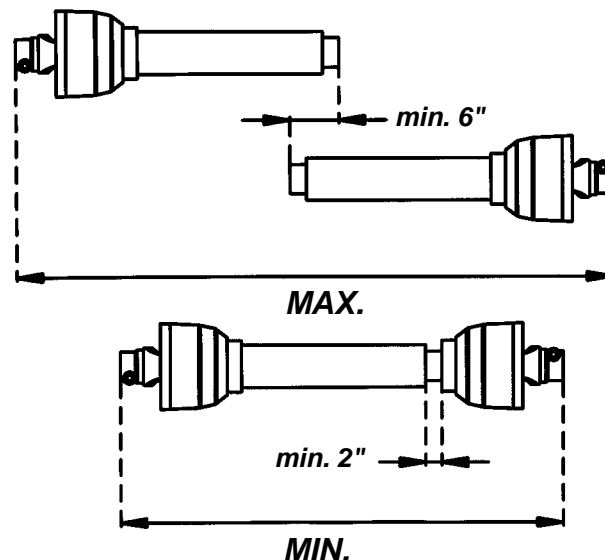









**CAUTION:** Always work with the driveline as straight as possible. This will prolong its life and that of its components. It is advised not to work at an angle greater than 15 degrees.

#### **4.04 - Ratchet Torque Limiter**

The tedder is supplied with a PTO driveline that comes equipped with a ratchet torque limiter. The PTO yoke end is attached to the tractor's PTO, while the end with the ratchet torque limiter is attached to the tedder.

The purpose of the limiter is to elastically transmit the desired torque to the unit, absorbing any overloads by temporarily slipping. When the torque limiter slips, disengage the PTO in order to prevent excessive wear.

**TABLE 1 - TORQUE SPECIFICATIONS**

Metric (ISO) treaded bolts head marking							Inch (SAE) treaded bolts head marking								
	Class 5.8		Class 8.8		Class 10.9			Grade 2		Grade 5		Grade 8			
Bolt size mm	Thread mm	N.m	ft-lb	N.m	ft-lb	N.m	ft-lb	Bolt size inch	Thread inch tpi	N.m	ft-lb	N.m	ft-lb	N.m	ft-lb
M5	0.8	4	3	6	4	9	7	1/4"	20	7	5	11	8	16	12
M6	1	6	4	10	7	15	11	1/4"	28	8	6	13	10	19	14
M8	1.25	16	12	25	18	36	27	5/16"	18	15	11	24	17	33	25
M8	1	17	13	26	19	38	28	5/16"	24	17	13	26	19	37	27
M10	1.5	31	23	48	35	71	52	3/8"	16	27	20	42	31	59	44
M10	1.25	33	24	51	38	75	55	3/8"	24	31	23	47	35	67	49
M10	1	35	26	53	39	78	58	7/16"	14	43	32	67	49	95	70
M12	1.75	54	40	84	62	123	91	7/16"	20	48	36	75	55	106	78
M12	1.5	56	41	87	64	128	94	1/2"	13	66	48	102	75	144	106
M12	1.25	59	44	90	66	133	98	1/2"	20	75	55	115	85	163	120
M14	2	84	62	133	98	195	144	9/16"	12	95	70	147	109	208	154
M14	1.5	94	69	142	105	209	154	9/16"	18	106	79	164	121	232	171
M16	2	131	97	206	152	302	223	5/8"	11	132	97	203	150	287	212
M16	1.5	141	104	218	161	320	236	5/8"	18	149	110	230	170	325	240
M18	2.5	181	133	295	218	421	310	3/4"	10	233	172	361	266	509	376
M18	2	196	145	311	229	443	327	3/4"	16	261	192	403	297	569	420
M18	1.5	203	150	327	241	465	343	7/8"	9	226	167	582	430	822	606
M20	2.5	256	189	415	306	592	437	7/8"	14	249	184	642	473	906	668
M20	1.5	288	212	454	335	646	476	1"	8	339	250	873	644	1232	909
M22	2.5	344	254	567	418	807	595	1"	12	371	273	955	704	1348	995
M22	1.5	381	281	613	452	873	644	1-1/8"	7	480	354	1077	794	1746	1288
M24	3	444	327	714	526	1017	750	1-1/8"	12	539	397	1208	891	1958	1445
M24	2	488	360	769	567	1095	808	1-1/4"	7	677	500	1519	1120	2463	1817
M27	3	656	484	1050	774	1496	1103	1-1/4"	12	750	553	1682	1241	2728	2012
M27	2	719	530	1119	825	1594	1176	1-3/8"	6	888	655	1992	1469	3230	2382
M30	3.5	906	668	1420	1047	2033	1499	1-3/8"	12	1011	746	2268	1673	3677	2712
M30	2	1000	738	1600	1180	2250	1659	1-1/2"	6	1179	869	2643	1949	4286	3161
M36	4	1534	1131	2482	1830	3535	2607	1-1/2"	12	1326	978	2974	2194	4823	3557

When using lock washers with nuts, increase torque values by 5%.

**TABLE 2 - ROTARY TEDDERS - TECHNICAL FEATURES**

Series DRO-330 & DRP-330, for tractors up to 50 HP, PTO 540 rpm							
Model	HP	Hitch type	Working width	Weight lb.	# of Rotors	# of Tines per rotor	Driveline w/ratchet torque limiter 1 3/8"
DRO-330	20-50	Three point	11"	441	2	6	ASAE 2 <sup>nd</sup> . cat.
DRP-330	20-50	Pull type	11"	457	2	6	ASAE 2 <sup>nd</sup> . cat.

## 5 - REPAIR PROCEDURES



**CAUTION:** All repair procedures must be done by authorized dealerships. It is not recommended that untrained individuals perform any repair work. The following operations are detailed for qualified personnel only.

### 5.01 - Rotor Timing

The rotor gears are timed at the factory and should not need to be serviced or re-timed. If, however, something happens that causes the gears to come out of time, follow the steps below to adjust timing:

1. On the gearbox of the rotor you are adjusting, loosen the bolts enough so that the gears are no longer meshing.
2. Turn the rotor until the tine arms on the rotor you are adjusting turn exactly in between the tine arms of the rotor next to it.
3. Once timing is adjusted and all tine arms mesh properly, tighten bolts on the gearbox.

If it is necessary to replace any part on the inside of the gearbox, it is important to replace oil seals or gaskets to ensure a tight fit when reassembling.

### 5.02 - Tine Replacement

Worn, broken or missing tines should be replaced as soon as possible to prevent damage to the tedder.

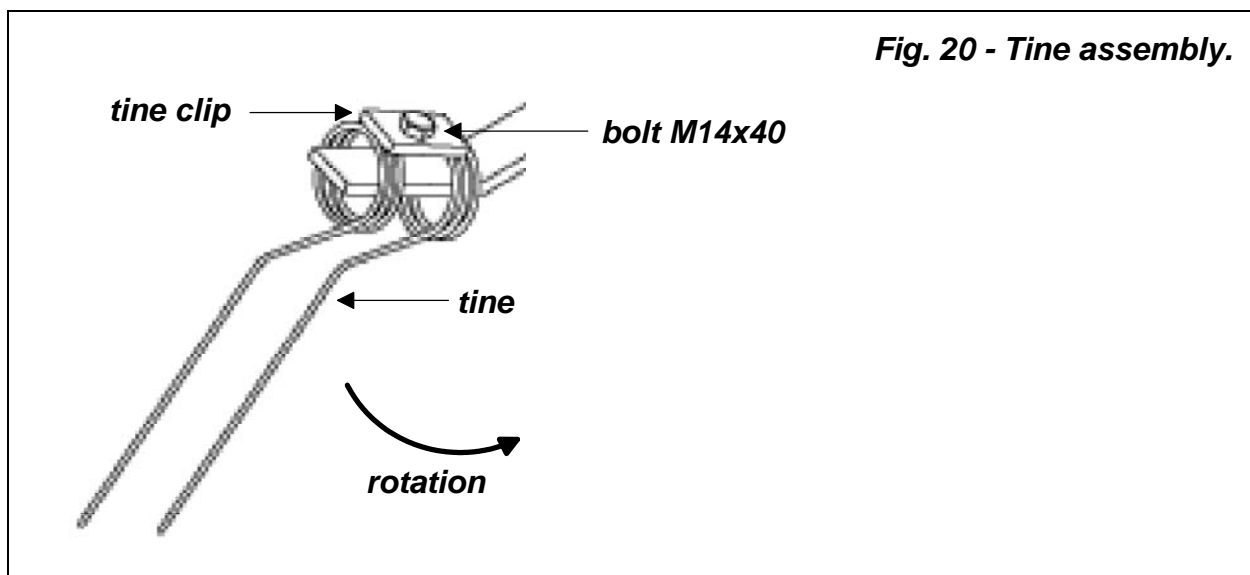

To replace a tine do the following:

1. Remove M14x40 bolt and M14 nut holding the tine that needs replacing.
2. Remove tine clip and tine and replace new tine making sure to assemble it so the tine is leading the arm when operating (**see fig. 20**).
3. Replace M14x40 bolt and M14 nut and tighten<sup>9</sup>.

### 5.03 - Suggested Spare Parts

It is suggested that the following spare parts be kept on hand for the tedder at all times to prevent a minor problem from delaying work.

Description	Quantity
Tines	1 set
Tine arms	2

### 5.04 - Storage

After seasonal use it is important to perform the following for prolonged storage:

1. Wash the tedder carefully.
2. Inspect the tedder and replace worn or damaged parts.
3. Tighten all hardware.
4. Grease all areas indicated under Maintenance<sup>10</sup>.
5. Cover the tedder from the elements in order to have it in perfect condition for the start of the next season.
6. Do not permit children to play on or around the stored unit.
7. Do not park or store equipment where it will be exposed to livestock for long periods of time. Damage and livestock injury could result.
8. Make sure all parked machines are on a hard, level surface, and engage all safety devices.



**WARNING:** Be sure to store the implement on a hard level surface and away from people especially children.

<sup>9</sup> See Table 1, page 29.

<sup>10</sup> See Chapter 4 - Maintenance.

## 6 - TROUBLESHOOTING



**WARNING:** Be sure tractor engine is off, parking brake is locked, and key is removed before making any adjustments.

PROBLEM	POSSIBLE CAUSE	SOLUTION
Tines hitting one another.	Rotor gears out of timing.	Adjust timing <sup>11</sup> .
Forage crop not being fluffed properly.	Dense or humid working conditions.	Select slower working speed.
	Incorrect working pattern.	Adjust working pattern <sup>12</sup> .
	Working speed too high.	Select slower working speed.
Forage crop gets dirty.	Tedder set too low.	Set front tedder tines so they sit 1" to 2" above the ground.

<sup>11</sup> See Section 5.01 - Rotor Timing.

<sup>12</sup> See Section 3.08 - Operating Techniques.



## 7 - PRE-DELIVERY CHECKLIST

**To the dealer: Inspect the machine thoroughly after assembly to assure it is functioning properly before delivering it to the customer. The following checklist is a reminder of points to cover. Check off each item as it is found satisfactory or after proper adjustment is made.**

- Gearbox oil level.
- Guards and shield properly fastened.
- Lubrication of grease fittings.
- All hardware properly tightened.
- All decals properly located and readable (**see fig. 2**).
- Tires are properly inflated.
- Overall condition (touch up scratches, clean and polish).
- Test run, check for excessive vibration or overheating of bearings.
- Operator's Manual.

**Review the Operator's Manual with the customer. Explain the following:**

- Warranty.
- Safe operation and service.
- Correct machine installation and operation.
- Daily and periodic lubrication, maintenance and inspections.
- Troubleshooting.
- Operational procedures and storage.
- Parts and service.
- Fill out the Pre-Delivery Checklist and Warranty Registration form.
- Give customer the Operator's Manual and encourage the customer to read the manual carefully.

**IMPORTANT: Warranty is not valid unless Pre-Delivery Checklist and Warranty Registration form in Operator's Manual is completed in detail and mailed to the Company.**

Model Number: \_\_\_\_\_

Serial Number: \_\_\_\_\_

Delivery Date: \_\_\_\_\_

Dealer's Signature: \_\_\_\_\_

## 8 - WARRANTY

BEFCO's responsibility will be limited to substitution of the acknowledged defective merchandise to the same place of delivery as the previous one was supplied.

### 1. LIMITED WARRANTY

BEFCO, Inc. herein referred to as the Company, warrants its machines and related accessories, hereafter referred to as the Machine, to be free from defects in material and workmanship, for a period of twelve (12) months from the date of invoice to the first registered owner; this limited warranty does not apply to common wear items and excludes belts, shear pins, oil, grease, tires, tubes, hydraulic hoses, knives and PTO shafts.

Labor will be reimbursed at \$40.00 per hour based on BEFCO's time schedule.

Cost of transport to the servicing dealer is the responsibility of the customer.

Warranty coverage shall not be transferable from the first owner to any subsequent owner.

### 2. DISCLAIMER OF ALL OTHER WARRANTIES AND REMEDIES

Neither the Company nor any company affiliated with the Company makes any warranties, representations or promises, expressed or implied, as to the quality, performance or application of its products other than those set forth herein and does not make any implied warranty of merchantability or fitness.

The only remedies the purchaser has in connection with the breach, or performance of any warranty on the Company's Machine are those set forth herein. In no event will the dealer, the Company, or any company affiliated with the Company, be liable for:

- a. Injuries or damages of any kind or nature, direct, consequential or contingent to person or property.
- b. Any expenses incurred by the owner to repair, replace or rework any allegedly defective item.
- c. Any loss, cost, forfeiture or damages (including loss of profits; loss of crops; loss because of delay in field operations; any expenses or loss incurred for labor, supplies, substitute machine rental; liabilities of the owner to its customers or third persons; and all other consequential damages, losses, liabilities or damages for any other reasons) whether direct or indirect, and whether or not resulting from or contributed to by the default or negligence of the Company, its agents, employees and subcontractors which might be claimed as a result of the use or failure of the equipment delivered.

The Company's liability based on this limited warranty or any other applicable laws shall be limited to replacement or refund of the purchase price of the product.

The limited warranty extended herein gives you specific rights and you may also have other rights which vary from state to state. Neither the dealer nor the Company personnel has the authority to make any representation or to modify the terms and limitations of this warranty in any way.

**Other than the limited warranty extended hereby there is no other expressed warranty in connection with the design, safety or use of any of the Company's products except as to title. All implied warranties are expressly disclaimed pursuant to the terms of this warranty.**

### **3. CUSTOM WORK**

If the Machine is used for commercial purposes such as custom work, the period warranted for the Machine is limited to six (6) months from the date of delivery to the first registered owner and does not cover any labor charges incurred.

### **4. RENTAL**

If the Machine is used for rental purposes the period warranted for the Machine is limited to thirty (30) days from the date of delivery to the first registered owner and does not cover any labor charges incurred.

### **5. REGISTRATION**

In order to qualify for coverage on this limited warranty, the product and name of the original purchaser must be registered with the Company by a completed Machine Pre-Delivery Checklist and Warranty Registration along with a copy of the dealer's invoice to the first registered owner to the Company within fourteen (14) days after the date of delivery to the original purchaser.

### **6. WARRANTY SERVICE**

Warranty Service must be performed by a dealer authorized by BEFCO. If the warranty service requested is approved, the owner shall pay only for labor beyond the rate allowed, for overtime labor, and for any mileage charge for transporting the equipment to and from the dealer's shop. It is assumed that the dealer has the appropriate general and special tools to service the Machine. Time required for replacement of knives, oil, grease and to remove excessive dirt from the Machine is not subject to reimbursement by the Company. The owner is required to clean the Machine before presenting it to the dealer for service work. The Machine must be delivered within thirty (30) days after failure date by the owner to the dealer to be eligible for warranty consideration.

### **7. UNAPPROVED SERVICE OR MODIFICATION**

All obligations of the Company under this limited warranty shall be terminated if:

- a. Proper service and operation instructions as outlined in the Operator's Manual and on the instruction sticker on the Machine, are not followed.
- b. The Machine is modified or altered in any way not approved by the Company.
- c. The Company does not receive a copy of the dealer's invoice to the first registered owner within fourteen (14) days from the date of delivery.
- d. The Company has not been paid in full, by the dealer, for the Machine.

### **8. ACCIDENTS AND NORMAL MAINTENANCE**

This limited warranty covers defective material and workmanship. It does not cover depreciation or damage caused by normal wear, accidents, improper maintenance, improper protection or improper use. The costs of normal maintenance or repairs for accidents or improper use, and related labor will be borne by the owner.

### **9. REPLACEMENT PARTS**

BEFCO, Inc. warrants replacement parts to be free from defect in material and workmanship for a period of thirty (30) days from the date of delivery to the original purchaser.



# WARRANTY REGISTRATION

**BEFCO, Inc.**  
**P.O. Box 6036**  
**Rocky Mount, NC 27802-6036**

**Tel: (252) 977.9920 - Fax: (252) 977.9718**

Dealer _____ Acct. # _____	Retail Customer _____
Street _____ Country _____	Street _____
Town _____ State _____ Zip _____	Town _____ State _____ Zip _____
Date of delivery _____ Invoice # _____	Phone _____
Model # _____ Serial # _____	
<p>Pre-Delivery Checklist:</p> <p><input type="checkbox"/> Oil in gearbox.</p> <p><input type="checkbox"/> Greased fittings.</p> <p><input type="checkbox"/> Safety guards in place.</p> <p><input type="checkbox"/> All hardware tight.</p> <p><input type="checkbox"/> Bolts torqued correctly.</p> <p><input type="checkbox"/> Attached unit to tractor. Yes/No.</p> <p><input type="checkbox"/> Field adjusted. Yes/No.</p> <p><input type="checkbox"/> Test run. Dry/Infield.</p> <p><input type="checkbox"/> Safety decals.</p> <p><input type="checkbox"/> Operator's Manual.</p> <p>The machine described above, has been prepared for delivery according to the Pre-Delivery Checklist and the Customer has been instructed in its care and operation and the condition of warranty.</p>	<p>Tractor make: _____</p> <p>Model: _____; HP _____</p> <p>Type of operation: Private homeowner, Landscaping, Commercial maintenance, Golf Course, Municipality, Turf Farm, others: _____</p> <p>Approximate number of acres machine will be used on annually: _____</p> <p>I hereby acknowledge that:  I have received and accepted delivery of the machine described.  The equipment was checked thoroughly for loose or missing parts and has been adjusted in accordance with the Pre-Delivery Checklist.  I have read and understand the nature and extent of the warranty and understand clearly that there were and are no other representations of warranties either expressed or implied, made by anyone. I have been advised on proper operation, maintenance and lubrication procedure of this equipment.  I have been instructed on and do understand the application, limitation and capacities this equipment was designed and recommended for, all as described in the Operator's Manual and literature published by the Company.</p>
Inspected by: _____	
Date: _____	Date: _____
Dealer's Signature: _____	Customer's Signature: _____

**This registration along with a copy of the invoice must be sent to BEFCO, Inc. within 14 days of date of purchase.**

*Sender:*

*Fold here*

---

*Place stamp  
here*

**BEFCO, Inc.**

Warranty Department

P.O. Box 6036

Rocky Mount, NC 27802-6036

*Cut along this line*



# **BEFCO®**

## **Parts Manual**

# **HAY EQUIPMENT**

## **Rotary Tedders**

### **DRO-330, DRP-330**

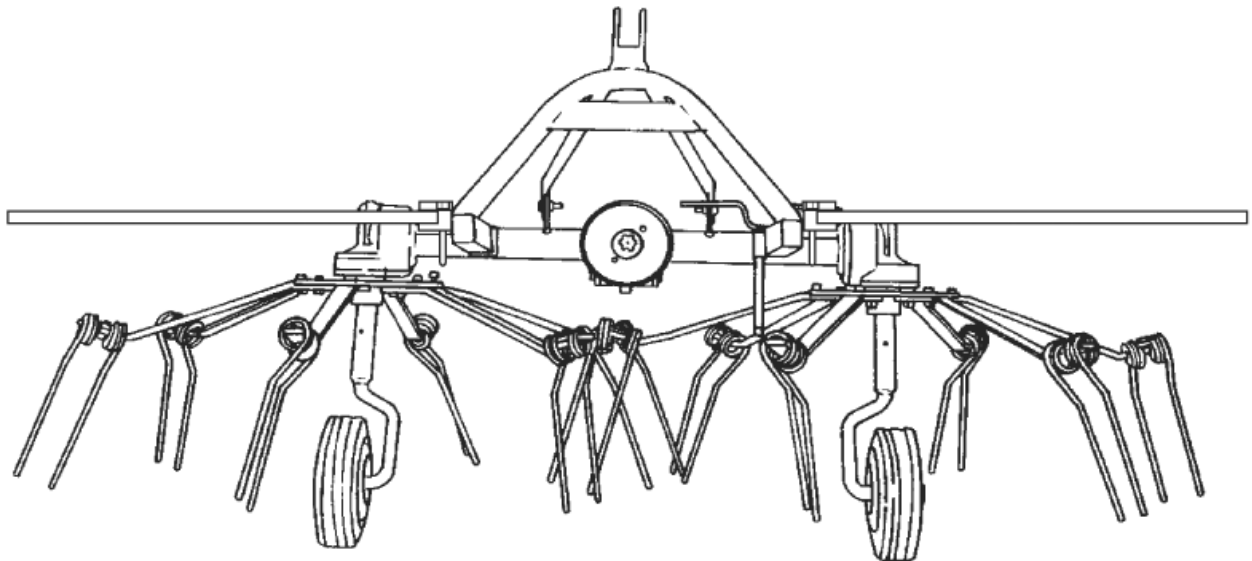

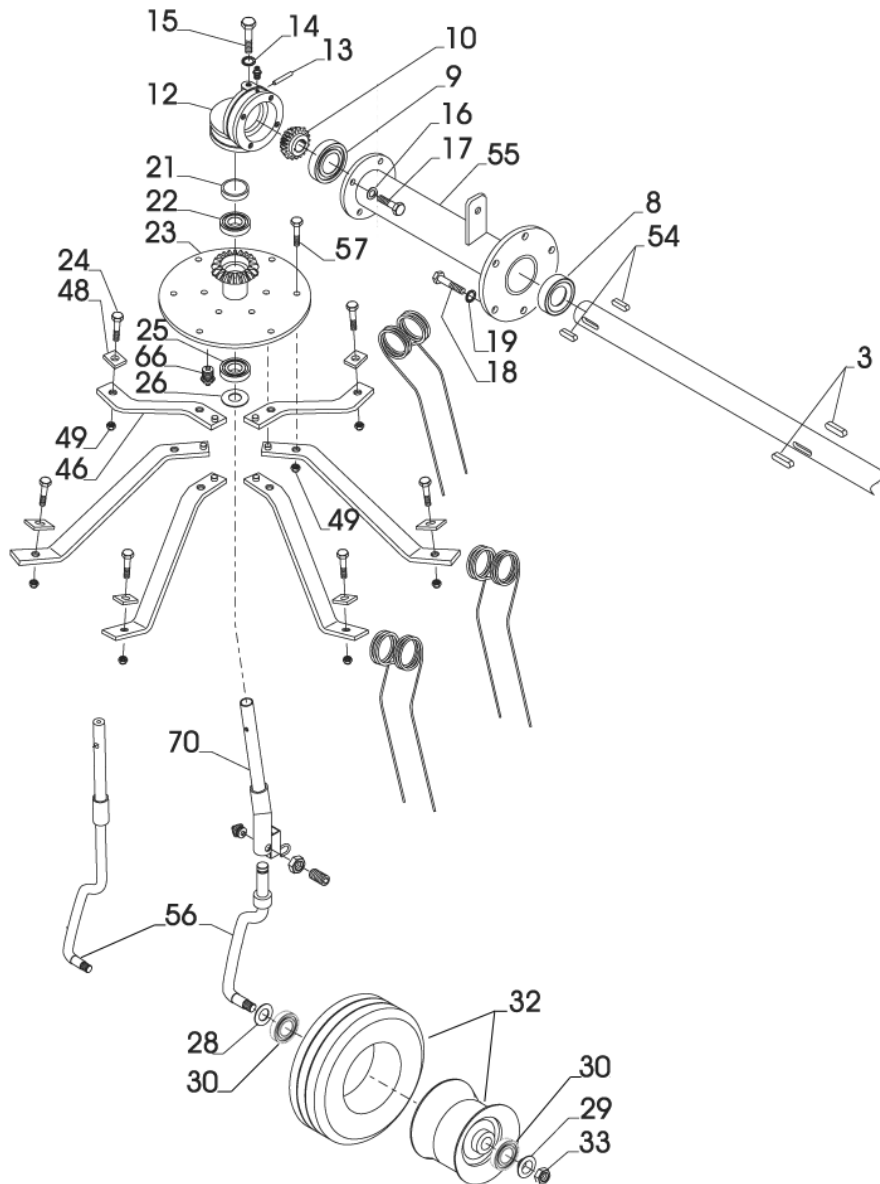



Ref.	Part #	Description	Qty.
3	502-343B	Key 10x8x30	2
8	502-346B	Oil seal Ø40x70x10	1
9	503-197B	Bearing 6207 2RS	1
10	502-347B	Lateral gear Z21	1
12	502-379B	Lateral gearbox housing	1
13	000-5522	Roll pin Ø10x50	1
14	003-0157	Washer, flat Ø10 Z	1
15	000-6349	Bolt HH M10-1.50x20 C8.8 Z F	1
16	502-972B	Lock washer Ø12 internal	4
17	002-3265	Bolt HH M12-1.75x40 C8.8 Z F	4
18	000-1278	Bolt HH M10-1.50x30 C8.8 Z F	6
19	501-861B	Lock washer Ø10 internal	6
21	502-360B	Spacer Ø30x42x21	1
22	004-1422	Bearing 6206	1
23	502-976B	Flange with gear	1
24	007-4232	Bolt HH M14-2.00x40 C8.8 Z F	6
25	005-8472	Bearing 30206	1
26	502-364B	Washer Ø30x60x5	1
28	502-373B	Inner cover	1
29	502-374B	Outer cover	1
30	000-6626A	Bearing 6205 ZZ	2
32	502-375B	Complete wheel 15x600-6	1
	503-624B	Inner spacer for wheel (not shown on image)	1
33	004-1165	Nut ES M16-2.00 Z TN	1
46	502-989B	Fixed tine arm	4
	502-990B	Adjustable tine arm	2
48	501-840B	Tine clip	6
49	001-5218	Nut ES M14-2.00 Z TN	10
54	000-6689	Key 8x7x30	2
55	502-965B	Drive tube right	1
56	502-370B	Wheel shaft right DRO-330	1
	502-980B	Wheel shaft right DRP-330	1
57	007-4232	Bolt HH M14-2.00x40 C8.8 Z F (fixed tine)	4
	502-977B	Bolt SH M14-2.00x25 C8.8 Z F (adjustable tine)	2
66	306-002F	Grease fitting M08-1.25	1
70	502-992B	Wheel support (DRO-330 only)	1

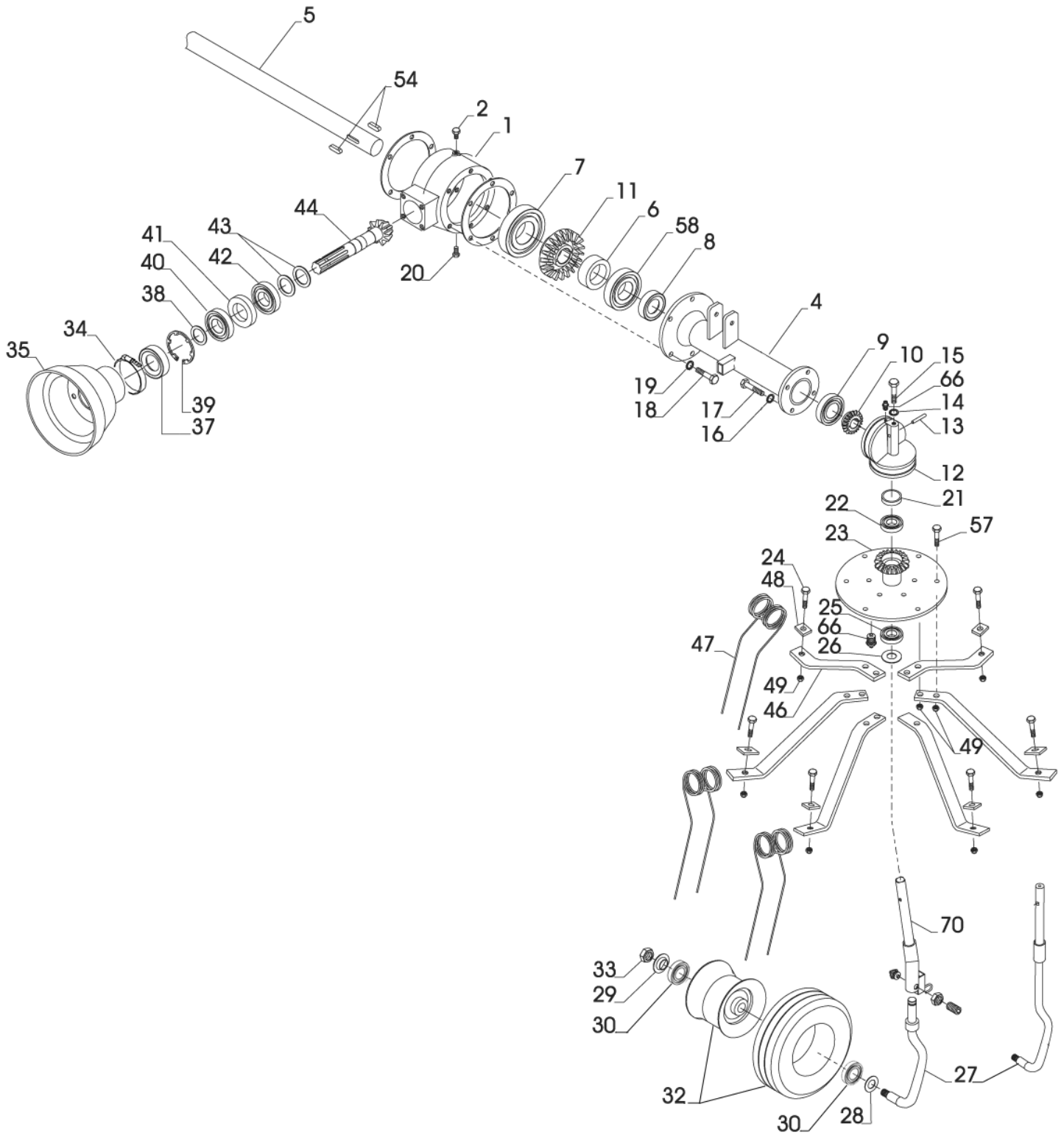

Ref.	Part #	Description	Qty.
1	502-327B	Gearbox housing	1
2	502-964B	Upper oil plug	1
4	502-966B	Drive tube left	1
5	502-967B	Central shaft	1
6	502-968B	Crown spacer Ø40x44x61	1
7	003-0201	Bearing 30208	1
8	502-346B	Oil seal Ø40x70x10	1
9	503-197B	Bearing 6207 2RS	1
10	502-347B	Lateral gear Z21	1
11	502-345B	Bevel gear Z27	1
12	502-379B	Lateral gearbox housing	1
13	000-5522	Roll pin Ø10x50	1
14	003-0157	Washer, flat Ø10x30	1
15	000-6349	Bolt HH M10-1.50x20 C8.8 Z F	1
16	502-972B	Lock washer Ø12 internal	4
17	002-3265	Bolt HH M12-1.75x40 C8.8 Z F	4
18	000-1278	Bolt HH M10-1.50x30 C8.8 Z F	6
19	501-861B	Lock washer Ø10 internal	6
20	502-974B	Lower oil plug	1
21	502-360B	Spacer Ø30x42x21	1
22	004-1422	Bearing 6206	1
23	502-976B	Flange with gear	1
24	007-4232	Bolt HH M14-2.00x40 C8.8 Z F	6
25	005-8472	Bearing 30206	1
26	502-364B	Washer Ø30x60x5	1
27	502-371B	Wheel shaft left DRO-330	1
	502-979B	Wheel shaft left DRP-330	1
28	502-373B	Inner cover	1
29	502-374B	Outer cover	1
30	000-6626A	Bearing 6205 ZZ	2
32	502-375B	Complete wheel 15x600-6	1
	503-624B	Inner spacer for wheel (not shown on image)	1
33	004-1165	Nut ES M16-2.00 Z TN	1
34	4010702	Hose clamp 90x110	1
35	502-984B	Protection (Clamp on)	1
	502-333B	Protection (Bolt on)	1
37	003-0211	Oil seal Ø35x72x10	1
38	004-2122	Snap ring, outer Ø35	1
39	002-5329	Snap ring, inner Ø72	1
40	002-5332	Bearing 6207	1
41	502-330B	Spacer Ø66x70x30	1
42	000-7172	Bearing 30207	1
43	502-329B	Shim Ø35x53x1	-
44	502-328B	Shaft	1
46	502-989B	Fixed tine arm	4
	502-990B	Adjustable tine arm	2
47	501-841B	Spring tine	12
49	001-5218	Nut ES M14-2.00 Z TN	10
54	000-6689	Key 8x7x30	2

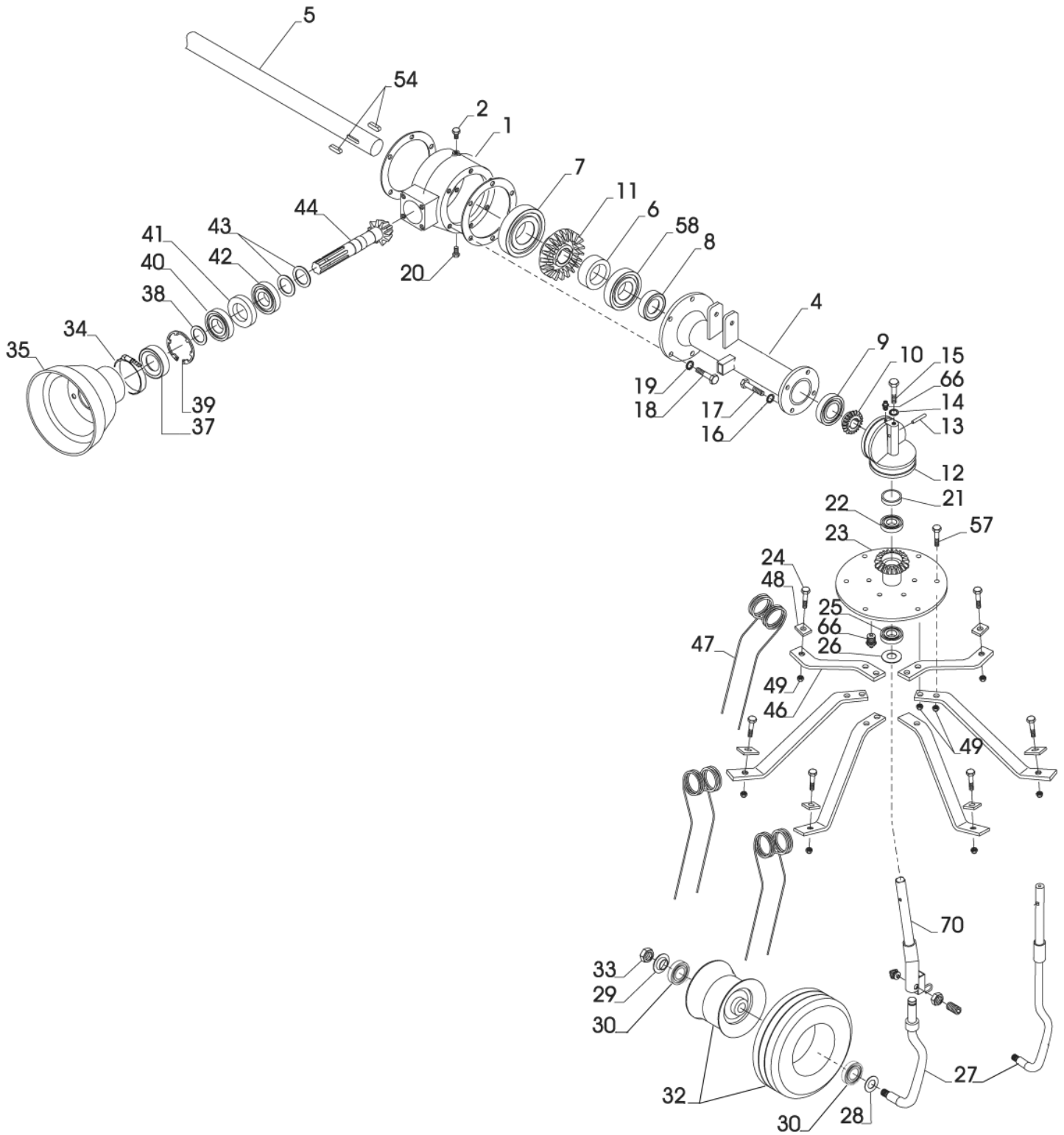

Ref.	Part #	Description	Qty.
57	007-4232	Bolt HH M14-2.00x40 C8.8 Z F (fixed tine)	4
	502-977B	Bolt SH M14-2.00x25 C8.8 Z F (adjustable tine)	2
58	001-2149	Bearing 6208	1
66	306-002F	Grease fitting M8-1.25	1
70	502-992B	Wheel support (DRO-330 only)	1

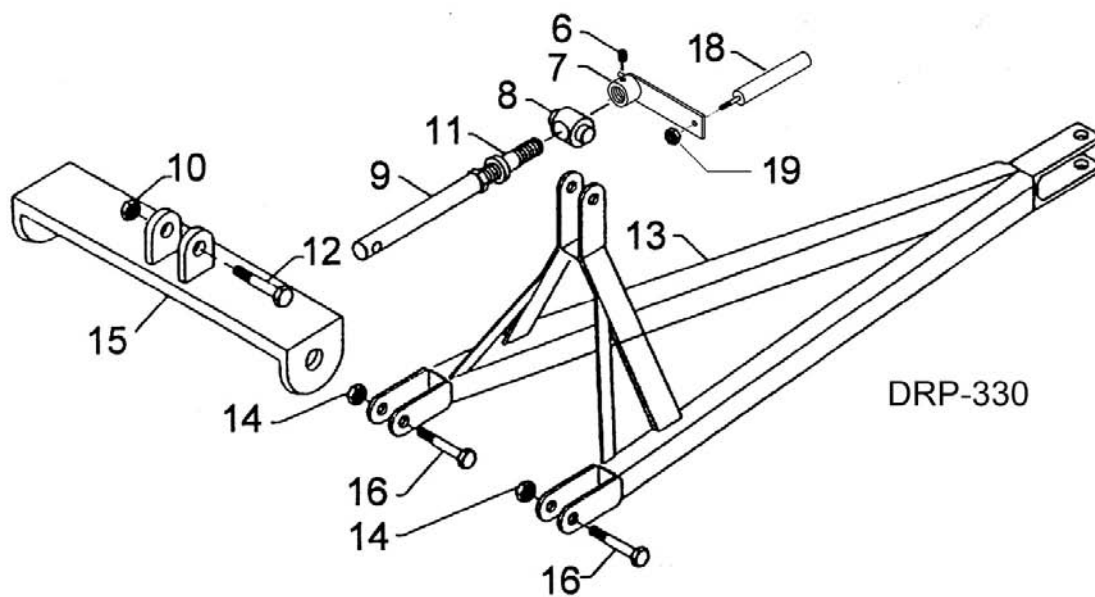
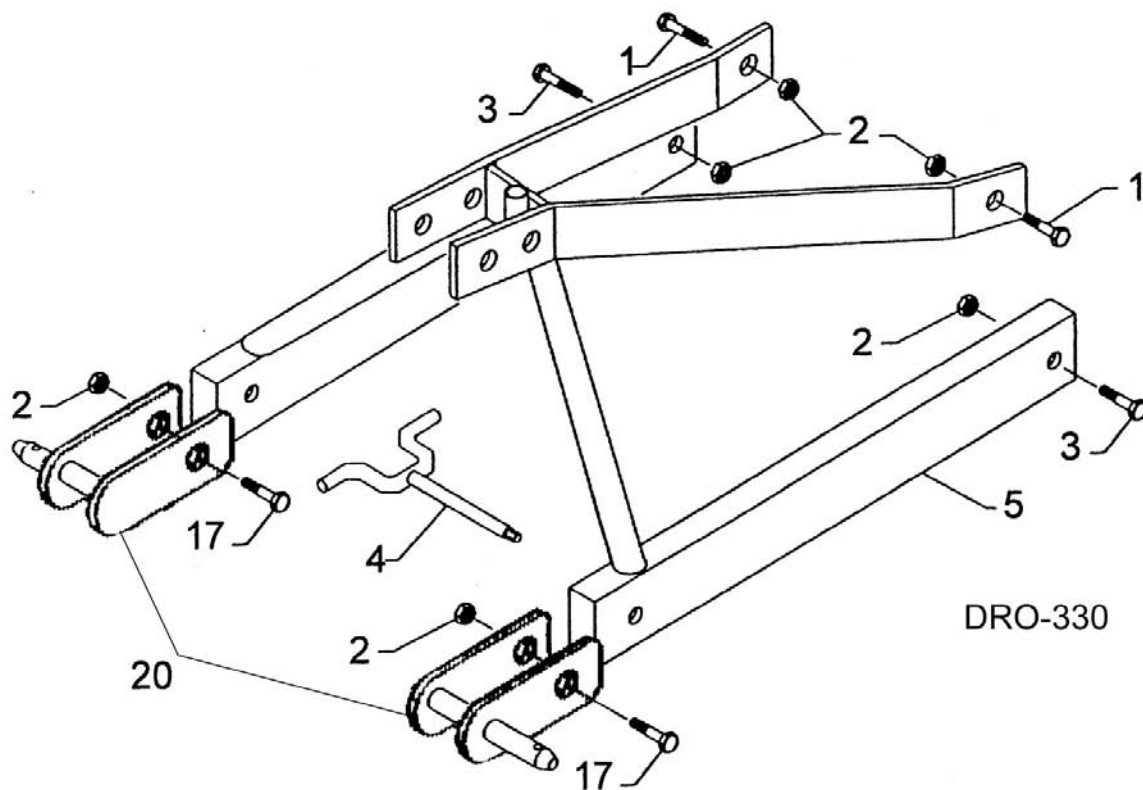

Ref.	Part #	Description	Qty.
1	003-2618	Bolt HH M14-2.00x30 C8.8 Z F	2
2	001-5218	Nut ES M14-2.00 Z TN	4
3	003-0277	Bolt HH M14-2.00x60 C8.8 Z P	2
4	502-995B	Tine arm wrench	1
5	502-996B	Three point hitch	1
6	000-6605	Roll pin Ø6x32	1
7	503-520B	Handle plate	1
8	503-521B	Pivot	1
9	503-522B	Adjustment tube	1
10	004-1165	Nut ES M16-2.00 Z TN	1
11	503-523B	Threaded rod	1
12	003-0309	Bolt HH M16-2.00x70 C8.8 Z F	1
13	503-003B	Pull type tongue	1
14	001-5218	Nut ES M14-2.00 Z TN	2
15	503-001B	Support bar	1
16	000-5536	Bolt HH M14-2.00x90 C8.8 Z P	2
17	003-0278	Bolt HH M14-2.00x80 C8.8 Z P	2
18	503-399B	Handle knob	1
19	001-4106	Nut ES M10-1.50 Z TH	1
20	503-606B	Floating linkage	2

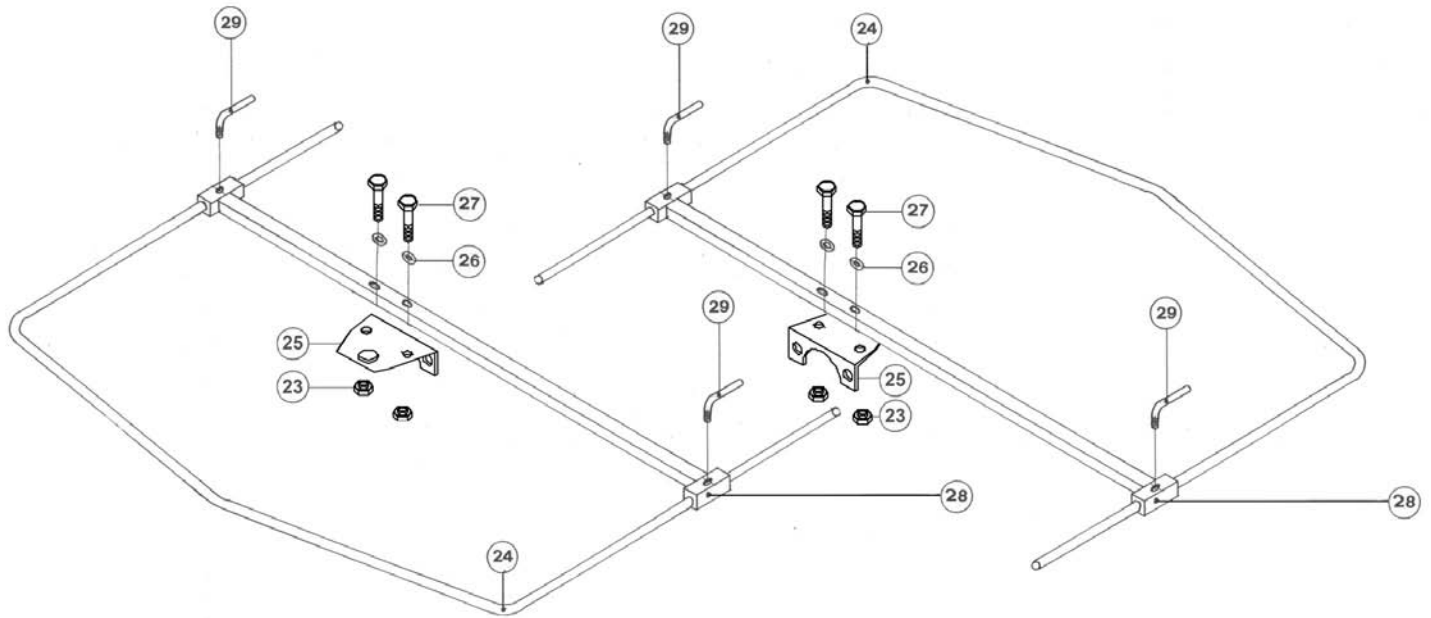

Ref.	Part #	Description	Qty.
23	003-0064	Nut PT M12-1.75 C6 Z	2
24	502-998B	Safety guard	2
25	3000320D	Safety guard support bracket	2
26	000-2265	Washer, flat Ø12	4
27	003-0054	Bolt HH M12-1.75x50 C8.8 Z F	4
28	8800240D	Guard support	2
29	502-997B	Knob M10	4



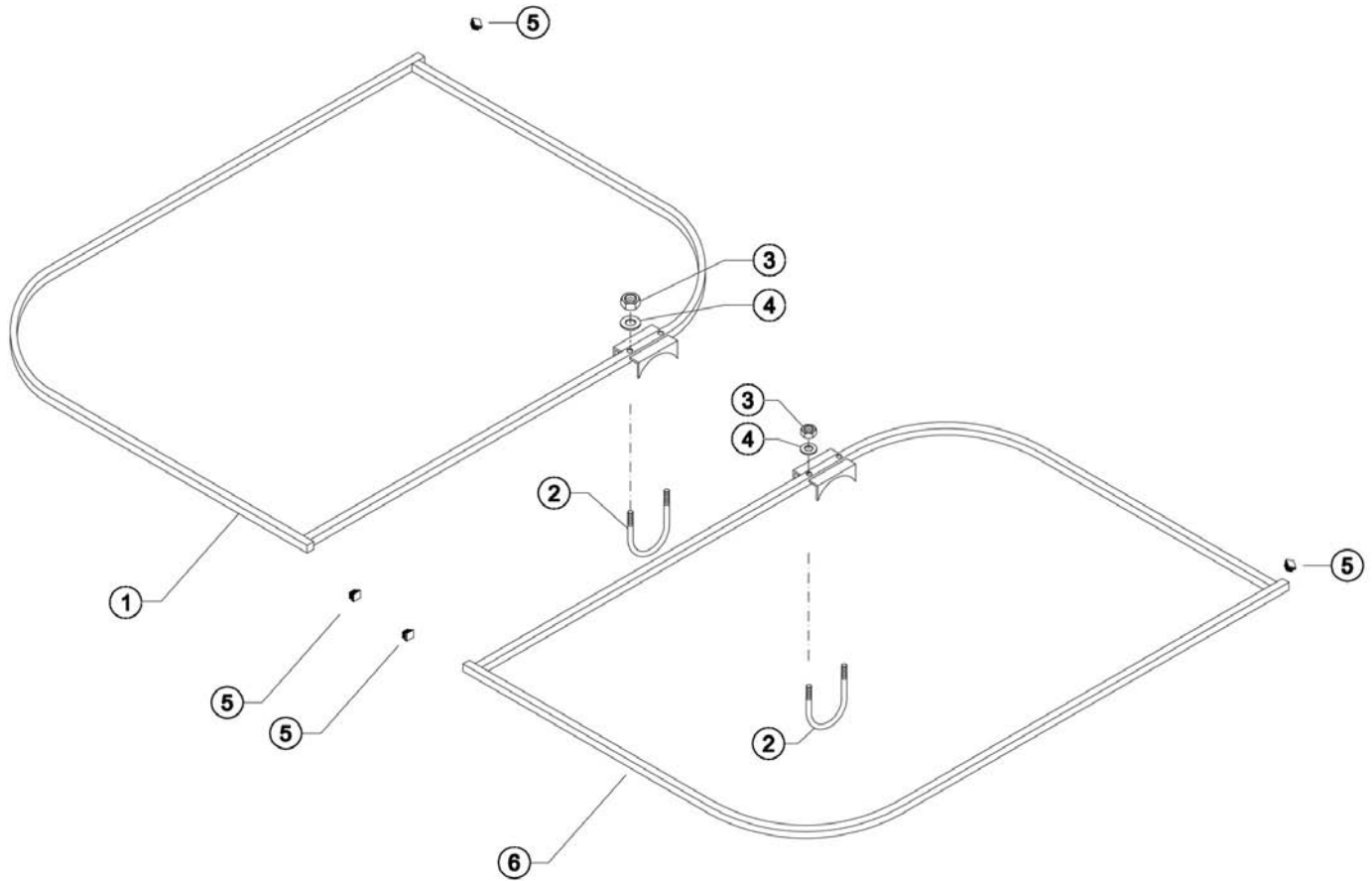

Ref.	Part #	Description	Qty.
1	503-568B	Right safety guard	1
2	502-999B	U bolt	2
3	001-3345	Nut ES M12-1.75 Z TK	2
4	000-2265	Washer, flat Ø12	2
5	8900405D	Plastic cap 25x25	4
6	503-567B	Left safety guard	1

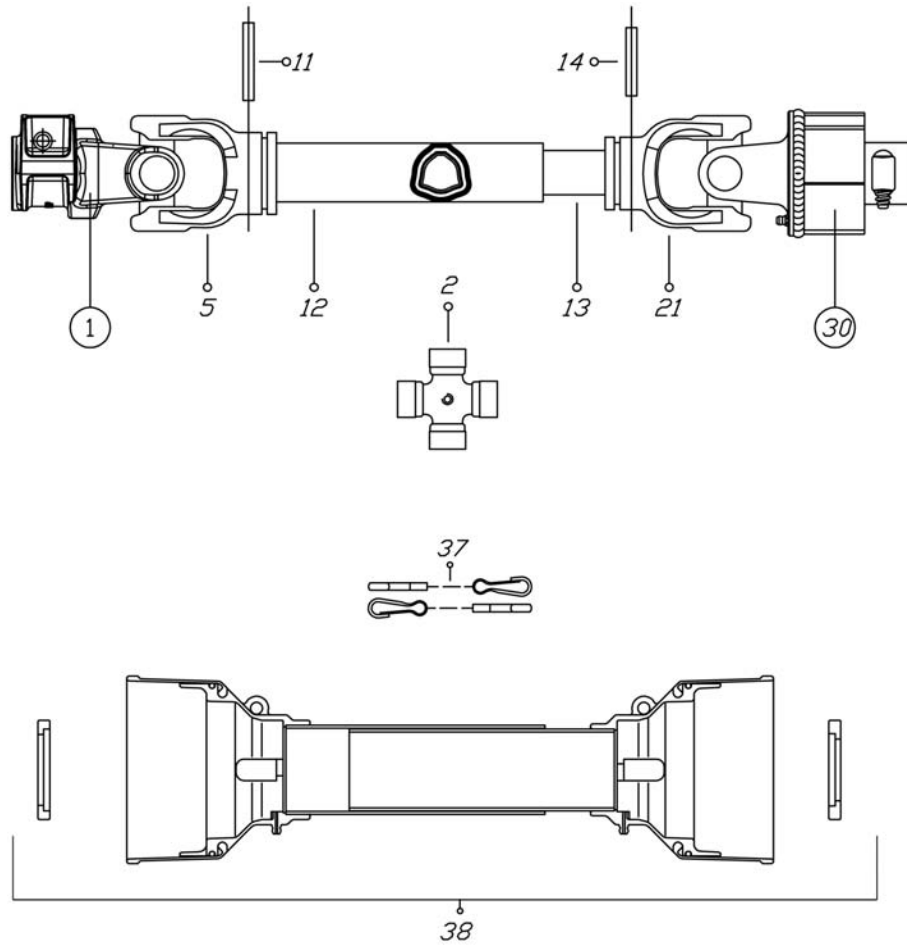

Ref.	Part #	Description	Qty.
1	1022010C	Yoke B2 - B1 3/8" Z6	1
2	1002020C	Cross & bearing B2 (23.8x61.3)	2
5	012-003E	Yoke, outer tube B2	1
11	000-012E	Roll pin Ø8x55	1
12	120-213E	Outer tube B2 - 36x3.2	1
13	120-113E	Inner tube B2 - 29x4	1
14	000-011E	Roll pin Ø8x50	1
21	012-002E	Yoke, inner tube B2	1
30	226-013E	Ratchet torque limiter LW2x02	1
37	1006065C	Chain, anti-rotation	2
38	083B02130	Shield, complete SS B2 1300	-
	950-463B	Decal "DANGER - Rotating driveline, keep away" outer shield	1
	950-464B	Decal "DANGER - Guard missing, do not operate" outer tube	1
	948-909B	PTO shaft complete w/ratchet torque limiter	-

## **Use only original spare parts**

*All rights reserved. It is unlawful to copy, reprint or use any of the information or details in this manual without the expressed written permission of the Company. Technical information provided in this manual is approximate, the Company reserves the right to modify or improve the models shown for technical or commercial purposes. Pictures in this manual do not necessarily show the machine as delivered.*

---

**BEFCO**<sup>®</sup>

P.O. Box 6036  
Rocky Mount, NC 27802-6036  
Tel.: 252.977.9920 - Fax: 252.977.9718  
[www.befco.com](http://www.befco.com)

