

BEFCO[®]

Operator's Manual

GROUND ENGAGE EQUIPMENT

Heavy Duty Rear Blades

BRB-284, BRB-296

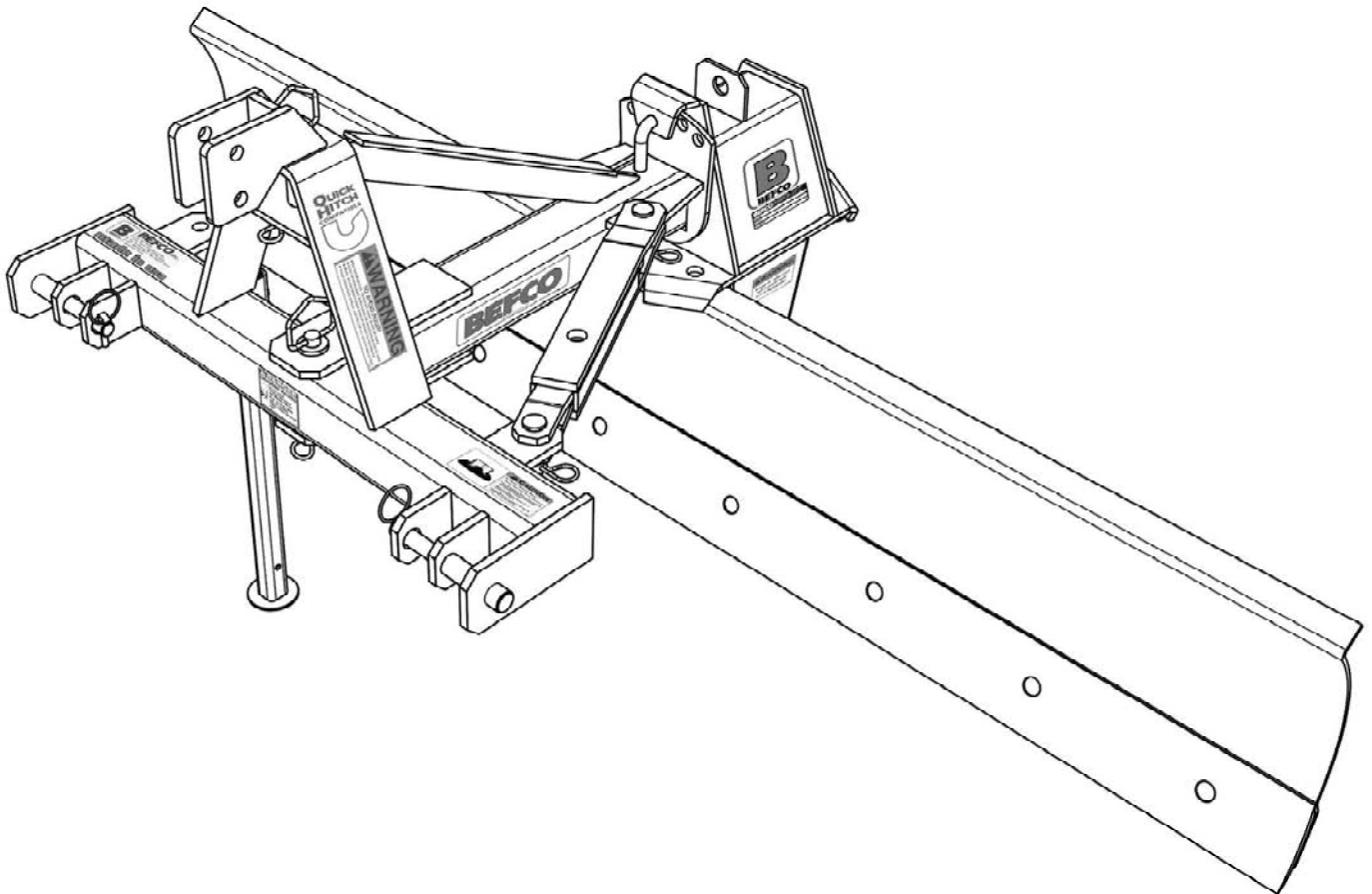

The operator's manual is a technical service guide and must always accompany the machine.

Manual 971-210B

December 2009

SAFETY

Take note! This safety alert symbol found throughout this manual is used to call your attention to instructions involving your personal safety and the safety of others. Failure to follow these instructions can result in injury or death.



*This symbol means:
ATTENTION!
BECOME ALERT!
YOUR SAFETY IS INVOLVED!*

Signal Words

Note the use of the signal words DANGER, WARNING and CAUTION with the safety messages. The appropriate signal words for each have been selected using the following guidelines:



DANGER: Indicates an imminently hazardous situation that, if not avoided, will result in death or serious injury.



WARNING: Indicates a potentially hazardous situation that, if not avoided, could result in death or serious injury, and includes hazards that are exposed when guards are removed. It may also be used to alert against unsafe practices.



CAUTION: Indicates a potentially hazardous situation that, if not avoided, may result in minor or moderate injury.

INDEX

1 - GENERAL INFORMATION	4
1.01 - General	4
1.02 - Model and Serial Number ID	4
1.03 - Assembly Instructions	5
2 - SAFETY PRECAUTIONS	7
2.01 - Preparation	7
2.02 - Starting and Stopping	8
2.03 - Messages and Signs	8
3 - OPERATION	10
3.01 - Operational Safety	10
3.02 - Setup	12
3.03 - Pre-Operational Check	12
3.04 - Attaching to the Tractor	12
3.05 - Start Up	13
3.06 - Working Speed	14
3.07 - Operating Techniques	14
3.08 - Optional Skid Shoes	18
3.09 - Optional Hydraulic Angling Cylinder	19
3.10 - Uneven Terrain	20
3.11 - Transport	20
4 - MAINTENANCE	21
4.01 - Maintenance Safety	21
4.02 - Service	22
5 - REPAIR PROCEDURES	24
5.01 - Cutting Blade Reversal or Replacement	24
5.02 - Suggested Spare Parts	25
5.03 - Storage	25
6 - TROUBLESHOOTING	26
7 - PRE-DELIVERY CHECKLIST	27
8 - WARRANTY	28
PARTS MANUAL	33

1 - GENERAL INFORMATION

Thank you and congratulations for having chosen our implement. Your new rear blade is a technologically advanced machine constructed of high quality, sturdy components that will fulfill your working expectations. Read this manual carefully. It will instruct you on how to operate and service your implement safely and correctly. Failure to do so could result in personal injury and/or in equipment damage.

1.01 - General



CAUTION: Right hand and left hand sides of the implement are determined by facing in the direction the implement will travel when going forward (see fig. 3).

1.02 - Model and Serial Number ID

Attached to the frame is an ID plate showing the model and the serial number. Record your implement model and serial number in the space provided below. Your dealer needs this information to give you prompt, efficient service when you order parts.

BEFCO	1781 S. Wesleyan Blvd. – P.O. Box 6036 Rocky Mount, N.C. 27802 – U.S.A. Tel: 1.252.977.9920 Fax: 1.252.977.9718
MODEL:	<input type="text"/>
SERIAL:	<input type="text"/>
VERSION:	<input type="text"/>

Carefully read the Warranty section¹, detailing coverage and limitations of this warranty. **Warranty** is provided for customers who operate and maintain their equipment as described in this manual. Warranty registration is accomplished by the dealer by completing and forwarding the **Warranty Registration** form to the Company, along with a copy of the dealer's invoice. It is in your best interest to insure that this has been done.

Warranty does not cover the following:

1. Cleaning, transporting, mailing and service call charges.
2. Normal wear items such as cutting blade, etc.

¹ See Chapter 8 - Warranty.

3. Depreciation or damage caused by normal wear, accidents, improper maintenance, improper protection or improper use.
4. The use of non-original spare parts and accessories.

Your Authorized Company Dealer has genuine parts in stock. Only these approved replacement parts should be used.

This limited warranty covers defective material and workmanship. The cost of normal maintenance or repairs for accidents or improper use and related labor will be borne by the owner.

1.03 - Assembly Instructions

For transportation purposes the main components of the rear blade are shipped unassembled.



CAUTION: Stand clear of bands when cutting as they could be under sufficient tension to cause them to fly loose. Take care in removing bands and wire. They often have extremely sharp edges and cut very easily.

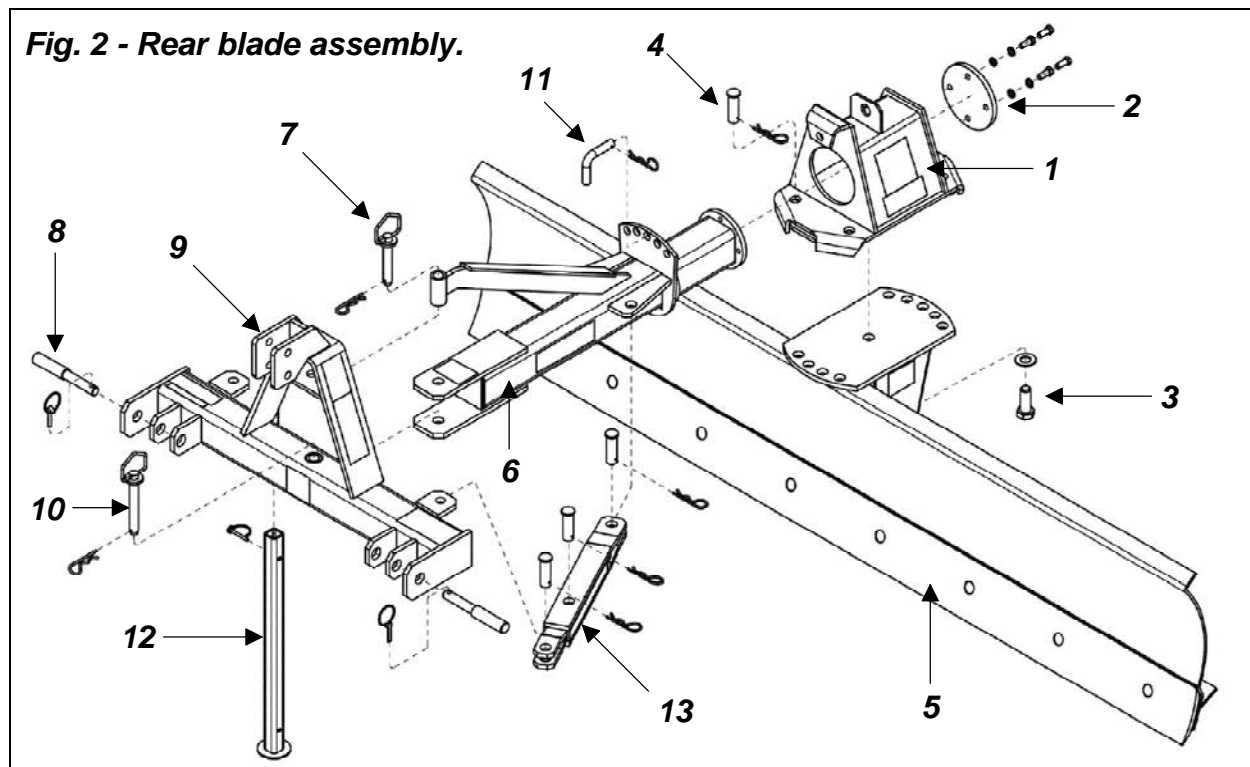

To assemble the rear blade proceed as follows (see fig. 2):

1. Securely block blade assembly (composed of moldboard (#5) and swivel box (#1) that are pre-assembled at the factory) with blocks or stands so that the swivel box (#1) is upward.

2. Ensure that the pivot bolt 1"-8x2.25" (#3) that attaches the moldboard to the swivel box is securely installed.
3. The swivel box cap (#2) must be removed in order to slide in the rear hitch frame (#6). Unbolt the swivel box cap (#2).
4. Slide the rear hitch frame through the swivel box, install swivel box pin (#11) and secure with "R" clip.
5. Reinstall the swivel box cap (#2) by applying the correct torque to the four bolts ½"-20x1.25"².
6. Position the "A" frame (#9) through the rear hitch frame (#6).
7. Insert pivot pin (#10) on bottom of "A" frame and through rear hitch frame and pivot pin (#7) on top of "A" frame and through rear hitch frame, secure both pins with "R" clips provided.
8. Insert the foot stand (#12) in storage position to support the blade and secure with lynch pin.
9. Install the adjustment brace (#13) to the left or to the right of the "A" frame assembly. IMPORTANT: The male end should be installed through the "A" frame (#9) and the female end through the rear frame (#6). Slide a flat head pin on each side and secure with "R" clips.
10. Insert the right and left hitch pins (#8) through the holes on the "A" frame and secure with lynch pins.
11. Ensure all hardware is properly tightened.



WARNING: Ensure that the pivot bolt that attaches the moldboard to the swivel box is always in place and properly tightened before assembly and before reversing the blade. If missing, the blade will fall and may cause serious injury.

² Refer to Table 1 - Torque Specifications, page 23.

2 - SAFETY PRECAUTIONS

Safety is the primary concern in the design and manufacture of our products. Unfortunately our efforts to provide safe equipment can be wiped out by a single careless act of an operator.

In addition to the design and configuration of equipment, hazard control and accident prevention are dependent upon the awareness, concern, prudence and proper training of personnel involved in the operation, transport, maintenance and storage of equipment. It is the operator's responsibility to read and understand all safety and operating instructions in the manual and to follow these.

Allow only properly trained personnel to operate the implement. Working with unfamiliar equipment can lead to careless injuries. Read this manual, and the manual for your tractor, before assembly or operation, to acquaint yourself with the machines. It is the owner's responsibility, if this machine is used by any person other than yourself, is loaned or rented, to make certain that the operator, prior to operating, reads and understands the operator's manuals and is instructed in safe and proper use.

2.01 - Preparation



1. Before operating equipment read and understand the operator's manual and the safety signs (**see fig. 3**).
2. Thoroughly inspect the implement before initial operation to assure that all packaging materials, i.e., wires, bands, and tape have been removed.
3. Personal protection equipment including hard hat, safety glasses, hearing protection, safety shoes, and gloves are recommended during assembly, installation, operation, adjustment, maintaining and/or repairing the implement.
4. Operate the implement only with a tractor equipped with an approved Roll-Over-Protective-System (ROPS). Always wear your seat belt. Serious injury or even death could result from falling off the tractor.
5. Clear area to be cut of stones, branches or other debris that might be thrown, causing injury or damage.
6. Before beginning operation, contact local utility companies to make certain there are no bundled gas lines, electrical cables, etc., in the work area.
7. Operate only in daylight or good artificial light.
8. Ensure implement is properly mounted, adjusted and in good operating condition.
9. Ensure that all safety decals are properly installed and in good condition.

2.02 - Starting and Stopping



1. Be sure that no one is near the machine prior to engaging or while the machine is working.
2. Be sure the tractor is in "Neutral" before starting engine.
3. Equipment operating power is ground driven. Know how to stop the tractor quickly in case of an emergency.
4. After striking an obstacle, shut the tractor off, remove key and thoroughly inspect for damage before restarting.

2.03 - Messages and Signs



1. Read and adhere to all safety and operating decals on this machine (**see fig. 3**).
2. Before dismounting tractor: Allow moving parts to stop, stop engine, set brake and remove the key of unattended equipment.
3. Keep safety decals in place and in good condition.
4. Do not use with bystanders in area.
5. Allow no riders on tractor or implement.
6. Allow moving parts to stop before repair.
7. Securely support implement before working underneath.

Additional warning and operating decals are available at no extra charge. Please specify model and serial number when ordering.

Fig. 3 - Safety decals - implement; replace immediately if damaged.

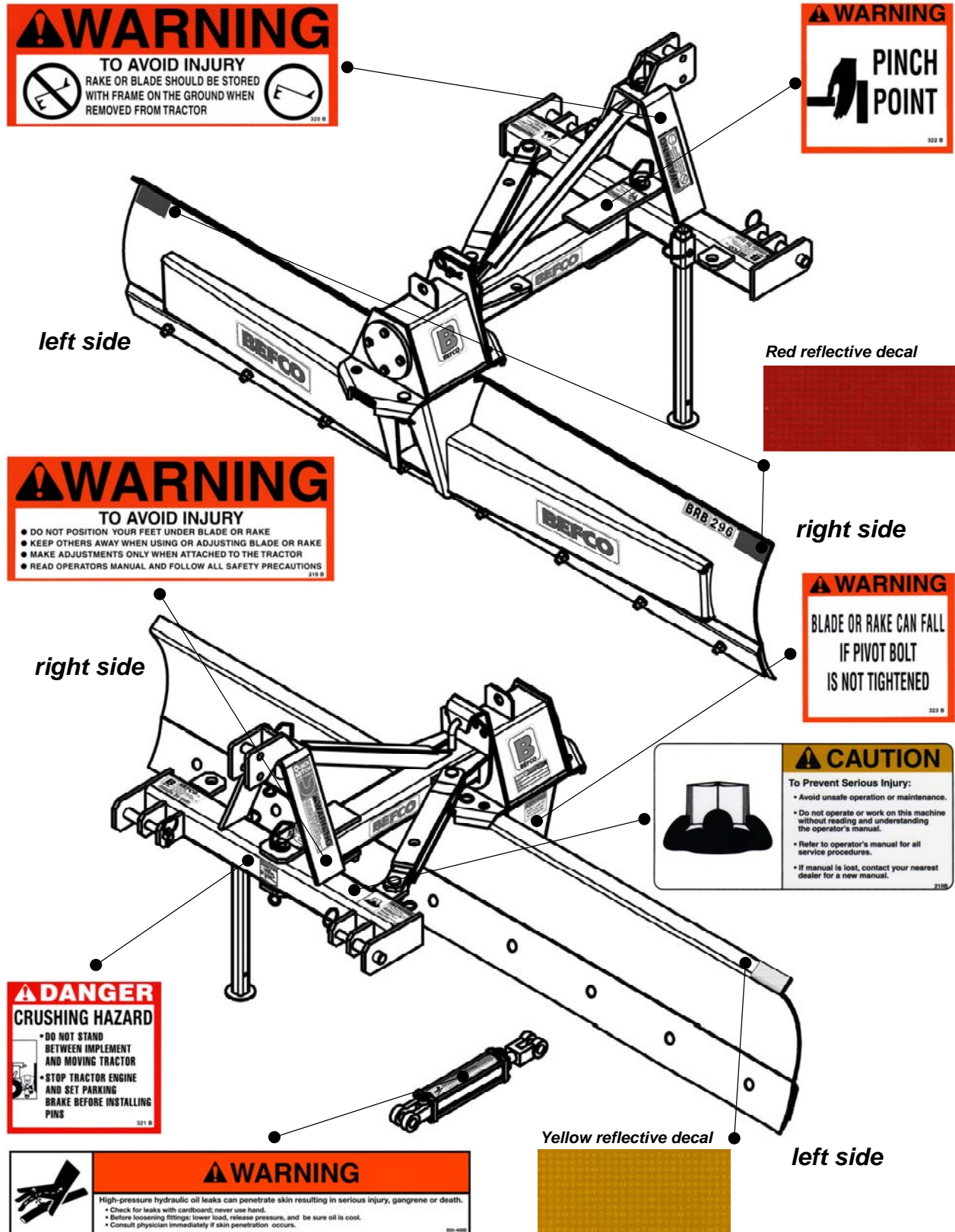

3 - OPERATION

You have purchased a heavy duty rear blade designed for snow removal, landscape grading, construction clean up, dirt leveling and backfilling applications. It is an ideal machine for hobby farmers, landscapers, nurseries and construction operations.

The heavy duty series, available in 84" and 96" (BRB-284 & BRB-296), are specifically designed for medium sized tractors with HP ranging from 30 to 80 and category 1 or 2 three point hitch or a category 1 or 2 Quick Hitch. These heavy duty blades feature a sturdy frame construction with ½"x6" heat treated reversible cutting edge blade, ¼" reinforced moldboard thickness, 11 offset possibilities (5 right, 5 left and 1 center) in 7.5 degrees increments that allow the operator to work next to walls or curbs, 5 tilt positions up to 30 degrees and offer 16 angling and 16 reversing capabilities up to 60 degrees.

Available options are: Skid shoes for easy height adjustment and a consistent finish and a hydraulic angling cylinder for quick and easy blade offset adjustment.

3.01 - Operational Safety



CAUTION: Our rear blades are designed considering safety as the most important aspect and are the safest available in today's market. Unfortunately, human carelessness can override the safety features built into our machines. Injury prevention and work safety, aside from the features on our rear blades, are very much due to the responsible use of the equipment. It must always be operated prudently following with great care, the safety instructions laid out in this manual.



1. The use of this equipment is subject to certain hazards which cannot be prevented by mechanical means or product design. All operators of this equipment must read and understand this entire manual, paying particular attention to safety and operating instructions, prior to using.
2. Do not operate the tractor and implement when you are tired, sick or when using medication.
3. Keep all helpers and bystanders at least several yards from the implement. Only properly trained people should operate this machine.
4. Accidents are most likely to occur with machines that are loaned or rented to someone who has not read the operator's manual and is not familiar with the implement.
5. Always stop the tractor, set brake, shut off the tractor engine, remove the ignition key, lower implement to the ground before dismounting tractor. Never leave equipment unattended with the tractor running.

6. Never place hands or feet under implement with tractor engine running or before you are sure all motion has stopped. Stay clear of all moving parts.
7. Do not reach or place yourself under equipment until it is blocked securely.
8. Do not allow riders on the implement or tractor at any time. There is no safe place for riders.
9. Before backing up, look behind carefully.
10. Never operate tractor and implement under trees with low hanging limbs. Operators can be knocked off the tractor and then run over by the implement.
11. The parts of this machine have been designed and tested for rugged use. However, they could fail upon impact with heavy, solid objects such as steel guard rails and concrete abutments. Such impact could cause the broken objects to be thrown outward at very high velocities. To reduce the possibility of property damage, serious injury, or even death, never allow the machine to contact such obstacles.
12. Frequently check cutting blade. It should be free of nicks and cracks and securely fastened.
13. Stop implement immediately upon striking an obstruction. Turn engine off, remove key, inspect and repair any damage before resuming operation.
14. Stay alert for holes, rocks and roots in the terrain and other hidden hazards. Keep away from drop-offs.
15. Use extreme care and maintain minimum ground speed when transporting on hillside, over rough ground and when operating close to ditches or fences. Be careful when turning sharp corners.
16. Before beginning operation, contact local utility companies to make certain there are no bundled gas lines, electrical cables, etc., in the work area.
17. Reduce speed on slopes and sharp turns to minimize tipping or loss of control. Be careful when changing directions on slopes. Do not start or stop suddenly on slopes. Avoid operation on steep slopes.
18. When using a unit, a minimum 20% of tractor and equipment weight must be on tractor front wheels. Without this weight, tractor could tip over, causing personal injury or death. The weight may be attained with a front end loader, front wheel weights, ballast in tires or front tractor weights. When attaining a minimum 20% of tractor and equipment weight on the front wheels, you must not exceed the ROPS weight certification. Weigh the tractor and equipment. Do not guess or estimate!
19. Inspect the entire machine periodically³. Look for loose fasteners, worn or broken parts, and leaky or loose fittings.
20. Pass diagonally through sharp dips and avoid sharp drops to prevent "hanging up" tractor and implement.
21. Avoid sudden starts and stops while traveling up or downhill.
22. Always cut down slopes; never across the face. Avoid operation on steep slopes. Slow down on sharp turns and slopes to prevent tipping and/or loss of control.
23. Comply with all federal, state and local laws during transport on roads.
24. Before parking the machine, lower the foot stand and secure it with the lock pins.

³ See Chapter 4 - Maintenance.

3.02 - Setup

Notice to dealer: Pre-delivery setup and service including lubrication is the responsibility of the authorized dealer. It is up to him to assure that the machine is in perfect condition and ready to be used. It is his responsibility to ensure that the customer is aware of all safety aspects and operational procedures for the implement. He must also fill out the Pre-Delivery Checklist⁴ prior to delivering the implement.

3.03 - Pre-Operational Check

IMPORTANT: Check each of the following, carefully, prior to engaging the equipment:

1. No wrappings or foreign objects are around the implement.
2. The cutting blade is properly installed and the bolts properly torqued⁵.
3. All hardware is tight.
4. No people or animals are in the work area.



WARNING: Ensure pivot bolt that attaches the moldboard to the pivot box is properly tightened to the welded nut. Blade can fall causing serious injury if pivot bolt is not securely installed.

3.04 - Attaching to the Tractor

Model BRB-284 and BRB-296 may be used on tractors with up to 80 HP and a category 1 or 2 three point hitch or a category 1 or 2 Quick Hitch⁶.



DANGER: Never allow anyone to stand between the rear blade and tractor during hookup operations.

To attach the rear blade to the tractor proceed as follows:

1. Back up the tractor to the rear blade until the draft links align with the lower hitch pins. The outer hitch position is for a category 2 lift arm and the inner hitch position is for a category 1 lift arm (**see fig. 4**).
2. Stop engine, engage parking brakes and remove key before dismounting tractor.
3. Secure the draft links by sliding the hitch pins through the bottom hitch holes on the "A" frame and through the draft links and secure them in place with lynch pins.
4. Raise foot stand all the way up and secure with lynch pin.
5. Attach top link to the top hitch of the rear blade "A" frame using a top link pin. The top hole is for a category 1 or 2 hitch (an optional bushing should be used for a category 2 hitch), the bottom hole is for a category 1 or 2 Quick Hitch (**see fig. 4**).

⁴ See Chapter 7 - Pre-Delivery Checklist.

⁵ See Table 1 - Torque Specifications, page 23.

⁶ See Table 2 - Technical Features, page 23.

6. Adjust the tractor sway chains/bars to center the rear blade behind the tractor and control the side sway.
7. Ensure blade is level by adjusting draft links and top link.
8. Slowly operate tractor controls up and down to ensure that the drawbar, tires and other equipment on the tractor does not touch the blade frame, moldboard or cutting blade. If necessary adjust or remove tractor drawbar to eliminate interference with blade. Ensure blade is at least 6" from tractor tires throughout the complete range of three point movement.

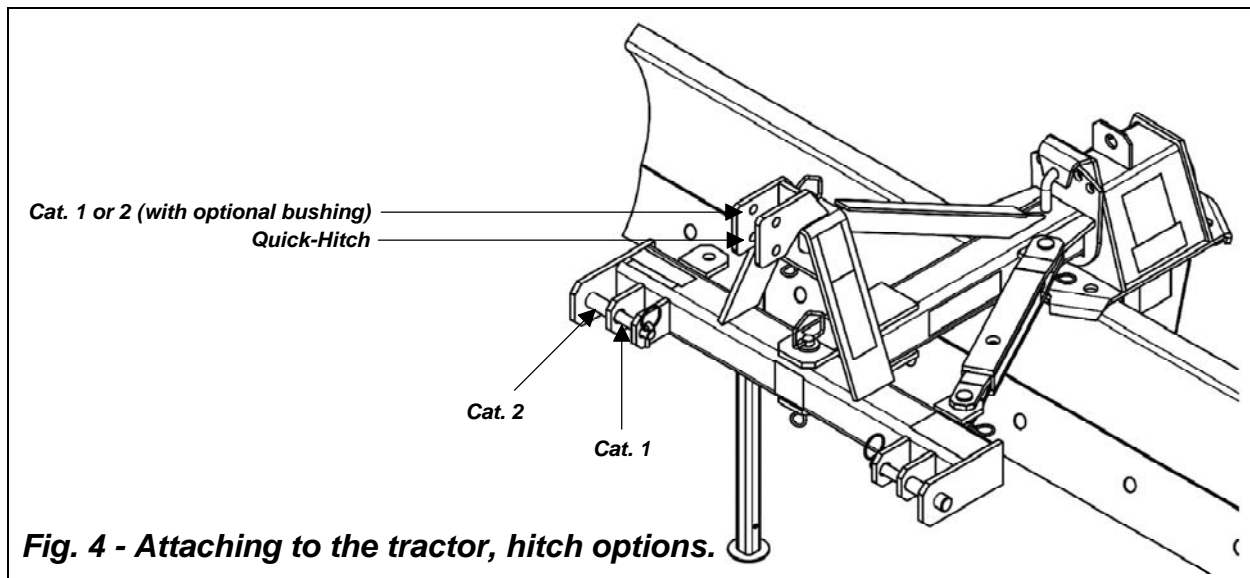

Fig. 4 - Attaching to the tractor, hitch options.



DANGER: Never attempt to attach the implement to the tractor or make any adjustments to it without first turning the tractor off.



DANGER: Failure to ensure a secure coupling of the implement to the tractor can cause injury and damage to the implement or tractor.

3.05 - Start Up



DANGER: Never allow anyone around the implement when it is in operation.



CAUTION: For emergency reasons, learn how to stop the tractor and implement quickly.

Before starting to work, never forget that the **operator is responsible** for the following:

1. Safe and correct driving of the tractor and implement.
2. To learn precise safe operating procedures for both the tractor and the implement.
3. To ensure all maintenance and lubrication has been performed on the implement.
4. To have read and understood all safety aspects for the implement in the operator's manual.
5. To have read and understood all safety decals on the implement.
6. To have contacted the local utility companies to make certain there are no bundled gas lines, electrical cables, etc., in the work area.
7. Checking the overall condition of the machine.
8. Checking to see if front weights need to be added to the tractor in order to maintain balance.
9. Checking the tractor tires for the proper pressure in accordance with the tractor operator's manual.
10. Making sure the proper attire is worn. Avoiding loose fitting clothing which can become entangled. Wearing sturdy, tough-soled work shoes and protective equipment for eyes, hands, ears and head. Never operate tractor or implements in bare feet, sandals or sneakers.
11. Checking area for stones, branches and other debris that might be thrown.
12. Ensuring proper lighting is available, sunlight or good artificial lighting.

3.06 - Working Speed

Ground speed is determined by the soil condition and tractor power. Simple experimentation will determine the best speed for the desired results, usually 2 to 5 mph.

3.07 - Operating Techniques

The heavy duty blade can be adjusted in several different positions and/or combination of positions to fit most of your application needs. It can be angled and reversed, it can be tilted and it can be offset to one side (**see fig. 5**).

Top link/scraping adjustment:

The rear blade level can be adjusted by adjusting the tractor's top link. Lengthening the top link will allow the blade to contact the ground at a sharper pitch and will result in a more aggressive action. Shortening the top link when scraping will raise the cutting blade to provide a more shallow cut.

Material may be spread by gradually raising the blade as the tractor moves forward. Loose material will require a different top link adjustment than hard or compacted soil.

Backfilling adjustment:

The scraper blade should be reversed and lowered to the ground before backing the tractor up to the fill material. Adjusting the top link will help control desired level of blade penetration.

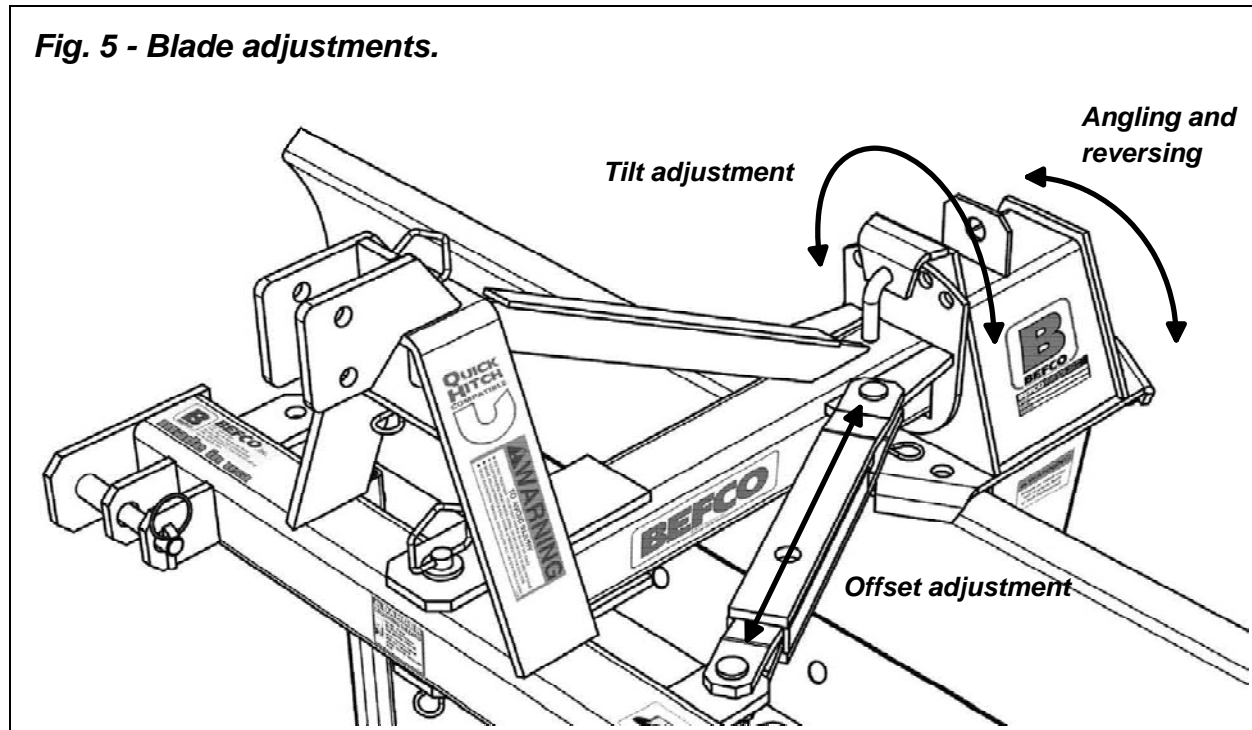

Reversing or angling adjustments (see fig. 6):

The heavy duty rear blade may be angled up to 60 degrees forward (8 positions to the right, 8 positions to the left and one center position) or, after turning the blade 180° it may be angled up to 60° in the reverse position for backfilling applications (8 positions to the right, 8 to the left and one center position). Each setting represents a 7.5 degree adjustment.

For some tractors blade can be rotated without unhooking from the tractor. Wider models may require disassembly of pivot bolt to reverse the blade.

To angle or reverse the blade proceed as follows:

1. Lift implement from the ground.
2. Remove "R" clips and pull out the 2 flat head swivel pins (see #4, fig. 2).
3. Set blade at desired angle and replace swivel pins and "R" clips.



WARNING: Ensure pivot bolt that attaches the moldboard to the pivot box is properly tightened to the welded nut. Blade can fall causing serious injury if pivot bolt is not securely installed.

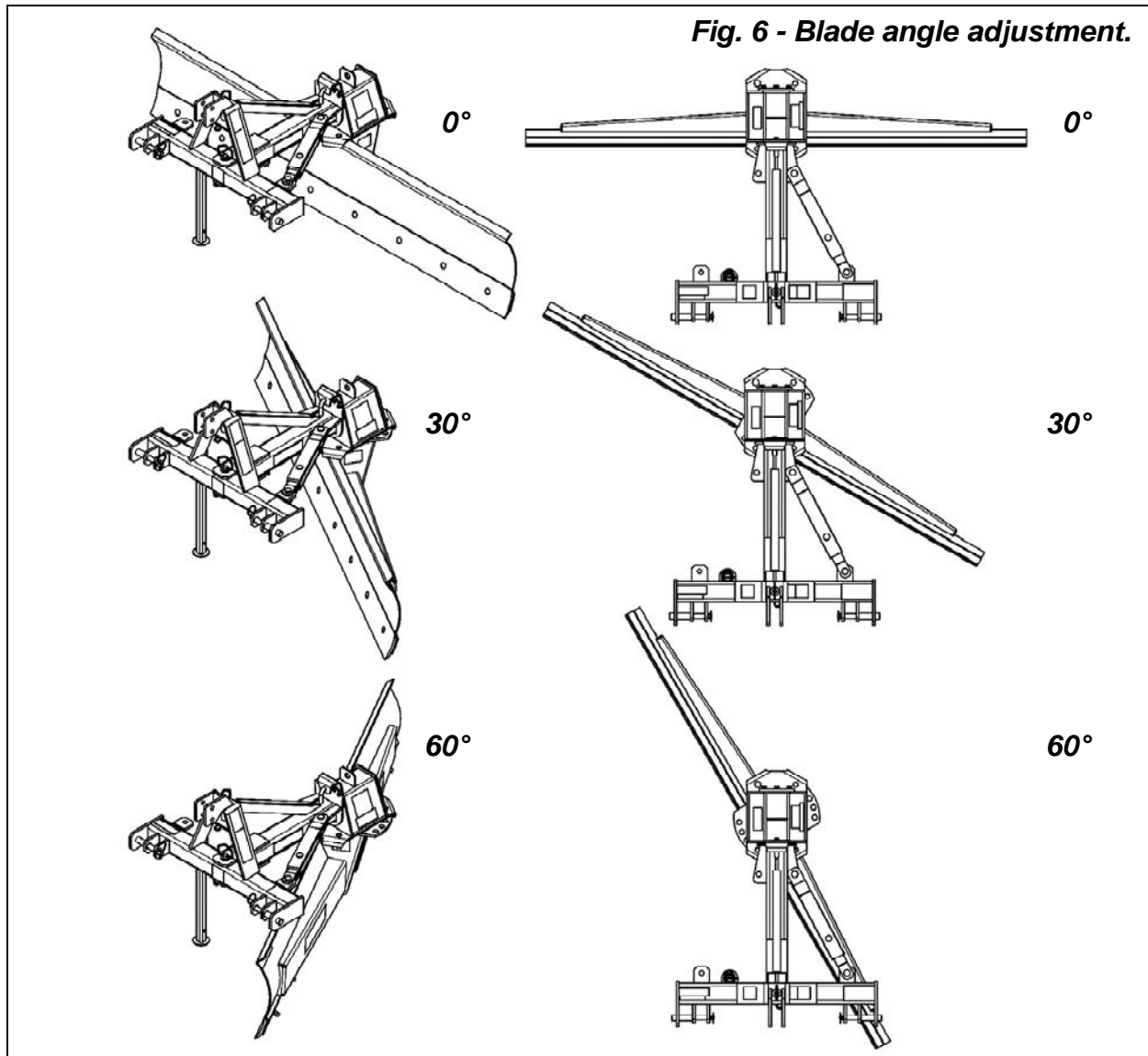

Tilt adjustment (see fig. 7):

On the heavy duty series (BRB-284 and BRB-296) the tilt of the blade can be adjusted by using one of the five tilt positions available on the blade swivel (2 on the right, 2 on the left and one center position). The blade can be tilted 15 or 30 degrees right or left by pulling out the tilt pin (see #11, fig. 2) on the swivel box (see #1, fig. 2) and replacing it at the desired tilt angle.



CAUTION: Depending on the size of the tractor, you may not be able to tilt the blade and still be able to raise it high enough to clear the ground during transport.

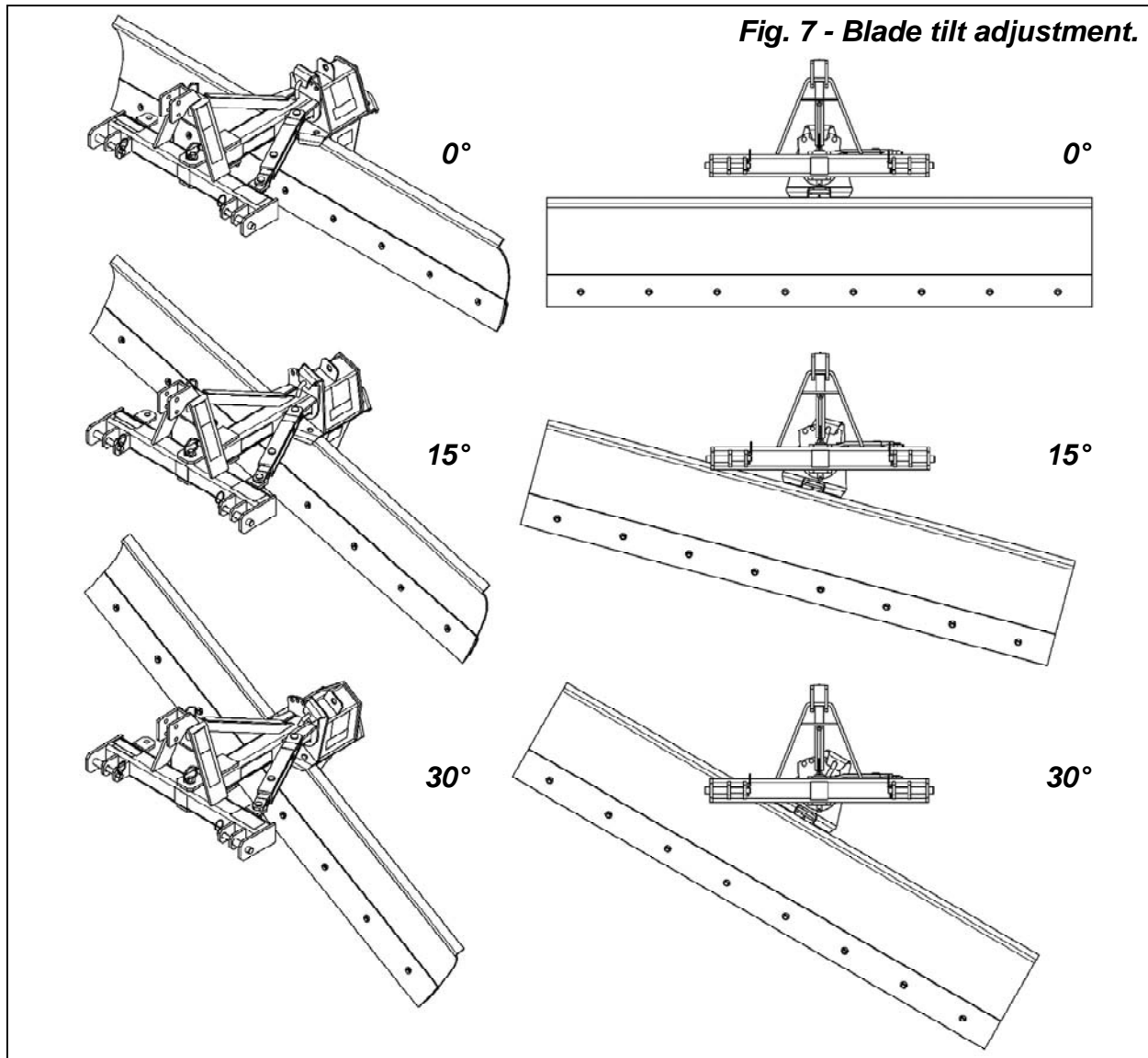

Offset adjustment (see fig. 8):

The rear blade can be offset to the right or to the left up to 37.5° by removing the flat head pin on the adjusting brace (see #13, fig. 2) and the pin on the moldboard assembly (see #4, fig. 2) and by swinging the frame to the desired position. Once in position reinstall the flat head pins and “R” clips.

NOTE: In order to offset the blade to the right, the adjustable brace must be mounted on the left side of the frame, and to offset the blade to the left the adjustable brace must be mounted to the right of the frame.

The optional hydraulic cylinder can be installed to offset blade by using the tractor's hydraulics to extend and retract the cylinder.

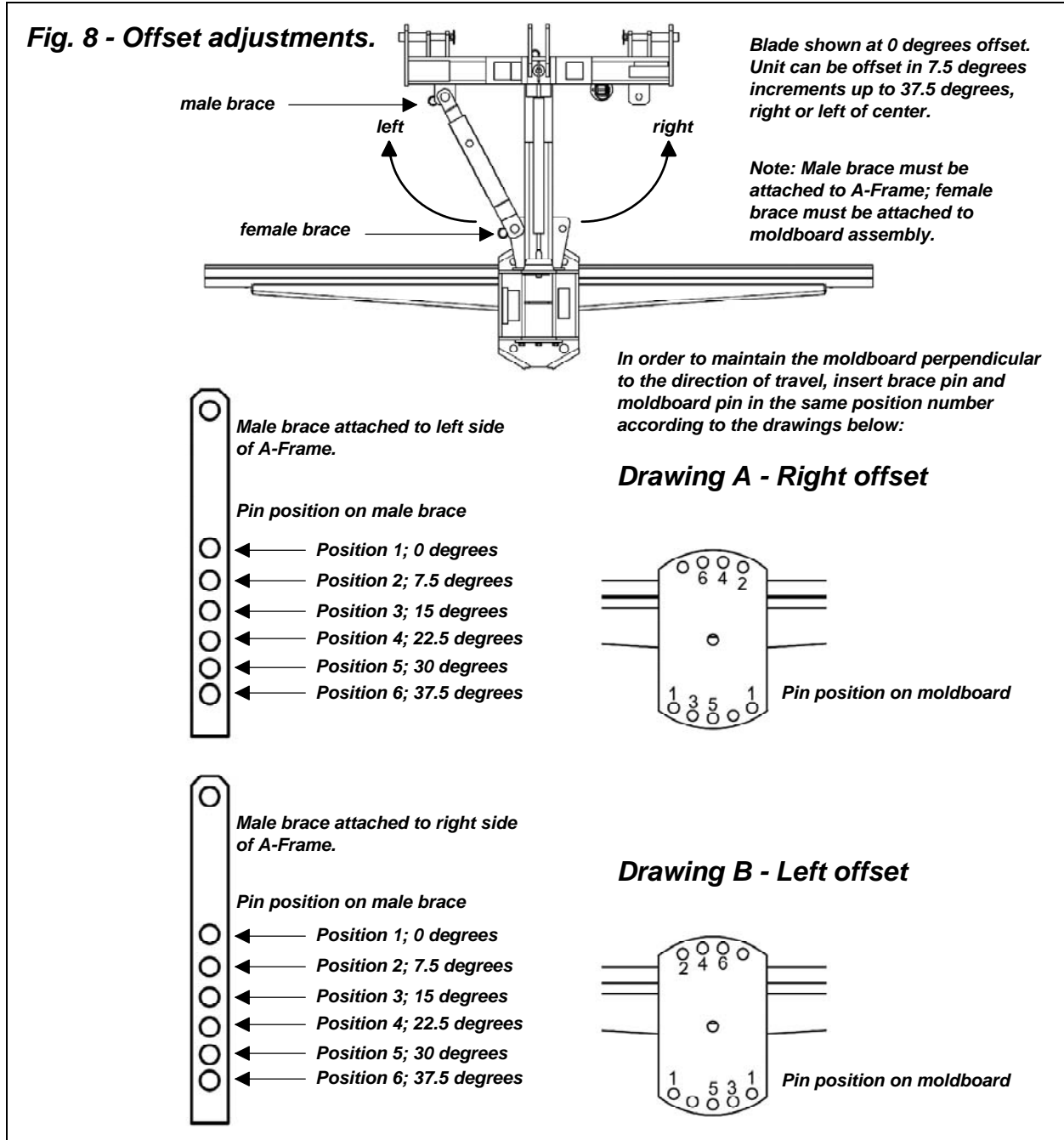

3.08 - Optional Skid Shoes

The optional skid shoes for easy height adjustment will enable a consistent finish.

To install the skid shoes proceed as follows:

1. Raise blade off the ground.
2. Stop engine, engage parking brakes and remove key before dismounting tractor.
3. Remove the 2 outermost 5/8"-11x1.75" plow bolts on each end of the blade.

4. Align slots on skid shoes to moldboard and install using two 5/8"-11x2" plow bolts, two 5/8" lock washers and two 5/8" hex nuts per side.
5. Ensure all hardware is properly tightened before resuming operation.

NOTE: Skid shoes should be rotated periodically from right to left to prolong their operational life.

3.09 - Optional Hydraulic Angling Cylinder

An optional hydraulic cylinder is available for quick and easy blade offset adjustments. The cylinder should be mounted in place of the adjustment brace. Mount the cylinder to the right of the frame to offset implement to the left or mount the cylinder to the left of the frame to offset implement to the right.

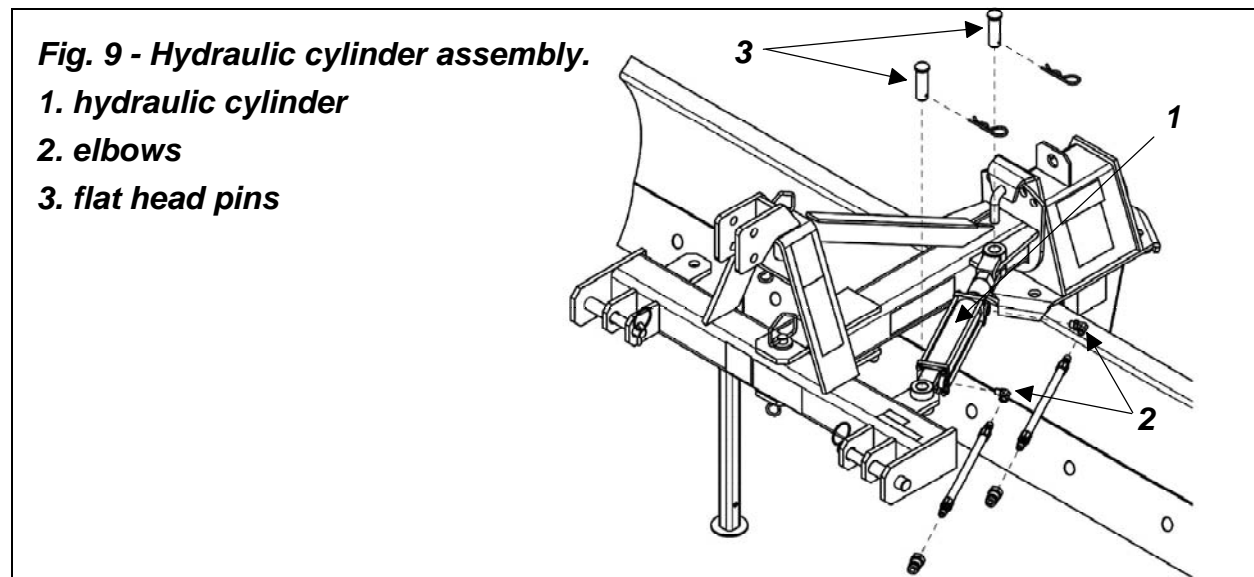

To install hydraulic cylinder proceed as follows (**see fig. 9**):

1. Lower foot stand to safely support implement.
2. Remove adjustment brace by removing both flat head pins.
3. Position the hydraulic cylinder (**#1**) with ports on top and with cylinder base towards the front mounting bracket (**see fig. 9**).
4. Insert the two flat head pins (**#3**) and secure with "R" clips.
5. Insert the 90° elbows (**#2**) on the cylinder ports.
6. Screw the hoses onto the elbows.
7. Screw the quick connect nipples on the hoses.
8. Connect hoses to the tractor's hydraulic system.
9. Ensure all hardware is properly tightened.



WARNING: High pressure hydraulic oil leaks can penetrate skin resulting in injury, gangrene or death. Be sure to relieve any hydraulic oil pressure before disconnecting any lines or pipes between implement and tractor hydraulic system. Check for oil leaks using a cardboard, never use hands.

3.10 - Uneven Terrain



DANGER: Be careful of rollover when operating tractor and implement over uneven ground.

The following precautions should always be observed when working on uneven terrain:

1. In extremely uneven terrain rear wheel weights, front tractor weights, and/or tire ballast should be used to improve stability.
2. Observe the type of terrain and develop a safe working pattern.
3. Operate the implement up and down steep slopes, not across slopes, to prevent the tractor from tipping. Avoid sudden stops and starts, and slow down before changing directions on a slope.
4. Pass diagonally through sharp dips and avoid sharp drops to prevent hanging up the tractor and implement.
5. Slow down on sharp turns and slopes to prevent tipping or loss of control.
6. Watch for holes, roots or other hidden objects. Do not use near the edge of a gully, ditch or stream bank.

3.11 - Transport



CAUTION: Do not tow tractor and implement behind other vehicles. Use a properly equipped trailer with heavy tie-downs for towing operations.

Before transporting:

1. Always select a safe ground speed that is appropriate for the terrain.
2. Beware of traffic on public roads. Install a SMV (Slow Moving Vehicle) sign when traveling on roads or streets. Comply with all federal, state and local laws.
3. Reduce ground speed when turning and take care that the implement does not strike obstacles such as trees, fences or buildings.

4 - MAINTENANCE



DANGER: Stop engine, lock parking brake and remove key before performing any service or maintenance.

Never rely on the tractor lift system. Install blocks or stands under the implement to prevent it from falling.

Always use personal protection devices, such as glasses or gloves when performing maintenance.

Keep fingers out of slots to prevent injury.

4.01 - Maintenance Safety



1. Good maintenance is your responsibility.
2. Keep service area clean and dry. Be sure electrical outlets and tools are properly grounded. Use adequate light for the job at hand.
3. Make sure there is plenty of ventilation. Never operate the engine of the towing vehicle in a closed building. The exhaust fumes may cause asphyxiation.
4. Make no repair or adjustments with the tractor engine running. Before working on the machine, shut off the engine, set the brakes, and remove the ignition key.
5. Be certain all moving parts have come to a complete stop before attempting to perform maintenance.
6. Never work under equipment unless it is blocked securely.
7. Always use personal protection devices such as eye, hand and hearing protectors, when performing any service or maintenance.
8. Frequently check blade. It should be free of nicks and cracks and securely fastened.
9. Periodically tighten all bolts, nuts and screws and check that all cotter pins are properly installed to ensure unit is in a safe condition.
10. After servicing, be sure all tools, parts and service equipment are removed.
11. Never replace hex bolts with less than grade five bolts unless otherwise specified, i.e. shear bolts⁷.
12. Where replacement parts are necessary for periodic maintenance and servicing, genuine replacement parts must be used to restore your equipment to original specifications. The company will not claim responsibility for use of unapproved parts and/or accessories and other damages as a result of their use.
13. Unauthorized modifications to the machine may impair the function and/or safety of the machine and reduce its life. If equipment has been altered in any way from original design, the manufacturer does not accept any liability for injury or warranty.

⁷ Refer to Table 1 - Torque Specifications, page 23.

4.02 - Service

Hourly or whenever an obstacle is hit:







1. Check machine condition, particularly the cutting blade.
2. Replace damaged or worn blade.
3. Remove any wrapping (stalks, weeds, trash, etc.) from implement.

Every 25 hours:

Check hardware tightness; vibration can loosen bolts⁸.

⁸ See Table 1, page 23.

TABLE 1 - TORQUE SPECIFICATIONS

Metric (ISO) treaded bolts head marking							Inch (SAE) treaded bolts head marking								
	Class 5.8		Class 8.8		Class 10.9			Grade 2		Grade 5		Grade 8			
Bolt size mm	Thread mm	N.m	ft-lb	N.m	ft-lb	N.m	ft-lb	Bolt size inch	Thread inch tpi	N.m	ft-lb	N.m	ft-lb	N.m	ft-lb
M5	0.8	4	3	6	4	9	7	1/4"	20	7	5	11	8	16	12
M6	1	6	4	10	7	15	11	1/4"	28	8	6	13	10	19	14
M8	1.25	16	12	25	18	36	27	5/16"	18	15	11	24	17	33	25
M8	1	17	13	26	19	38	28	5/16"	24	17	13	26	19	37	27
M10	1.5	31	23	48	35	71	52	3/8"	16	27	20	42	31	59	44
M10	1.25	33	24	51	38	75	55	3/8"	24	31	23	47	35	67	49
M10	1	35	26	53	39	78	58	7/16"	14	43	32	67	49	95	70
M12	1.75	54	40	84	62	123	91	7/16"	20	48	36	75	55	106	78
M12	1.5	56	41	87	64	128	94	1/2"	13	66	48	102	75	144	106
M12	1.25	59	44	90	66	133	98	1/2"	20	75	55	115	85	163	120
M14	2	84	62	133	98	195	144	9/16"	12	95	70	147	109	208	154
M14	1.5	94	69	142	105	209	154	9/16"	18	106	79	164	121	232	171
M16	2	131	97	206	152	302	223	5/8"	11	132	97	203	150	287	212
M16	1.5	141	104	218	161	320	236	5/8"	18	149	110	230	170	325	240
M18	2.5	181	133	295	218	421	310	3/4"	10	233	172	361	266	509	376
M18	2	196	145	311	229	443	327	3/4"	16	261	192	403	297	569	420
M18	1.5	203	150	327	241	465	343	7/8"	9	226	167	582	430	822	606
M20	2.5	256	189	415	306	592	437	7/8"	14	249	184	642	473	906	668
M20	1.5	288	212	454	335	646	476	1"	8	339	250	873	644	1232	909
M22	2.5	344	254	567	418	807	595	1"	12	371	273	955	704	1348	995
M22	1.5	381	281	613	452	873	644	1-1/8"	7	480	354	1077	794	1746	1288
M24	3	444	327	714	526	1017	750	1-1/8"	12	539	397	1208	891	1958	1445
M24	2	488	360	769	567	1095	808	1-1/4"	7	677	500	1519	1120	2463	1817
M27	3	656	484	1050	774	1496	1103	1-1/4"	12	750	553	1682	1241	2728	2012
M27	2	719	530	1119	825	1594	1176	1-3/8"	6	888	655	1992	1469	3230	2382
M30	3.5	906	668	1420	1047	2033	1499	1-3/8"	12	1011	746	2268	1673	3677	2712
M30	2	1000	738	1600	1180	2250	1659	1-1/2"	6	1179	869	2643	1949	4286	3161
M36	4	1534	1131	2482	1830	3535	2607	1-1/2"	12	1326	978	2974	2194	4823	3557

When using lock washers with nuts, increase torque values by 5%.

TABLE 2 - REAR BLADES - TECHNICAL FEATURES

Heavy duty series, for tractors up to 80 HP, 3 point hitch cat. 1 & 2					
Model	Working width	Weight lb.	Tilt adjustment	Blade angling	Offset adjustment
BRB-284	84"	524	15° and 30°	up to 60°	up to 37.5°
BRB-296	96"	561	15° and 30°	up to 60°	up to 37.5°

5 - REPAIR PROCEDURES



CAUTION: All repair procedures must be done by authorized dealerships. It is not recommended that untrained individuals perform any repair work. The following operations are detailed for qualified personnel only. Never work under the implement without properly blocking the unit.

5.01 - Cutting Blade Reversal or Replacement



CAUTION: Always keep feet away from the blade. It is possible that it could slip and fall causing injury.

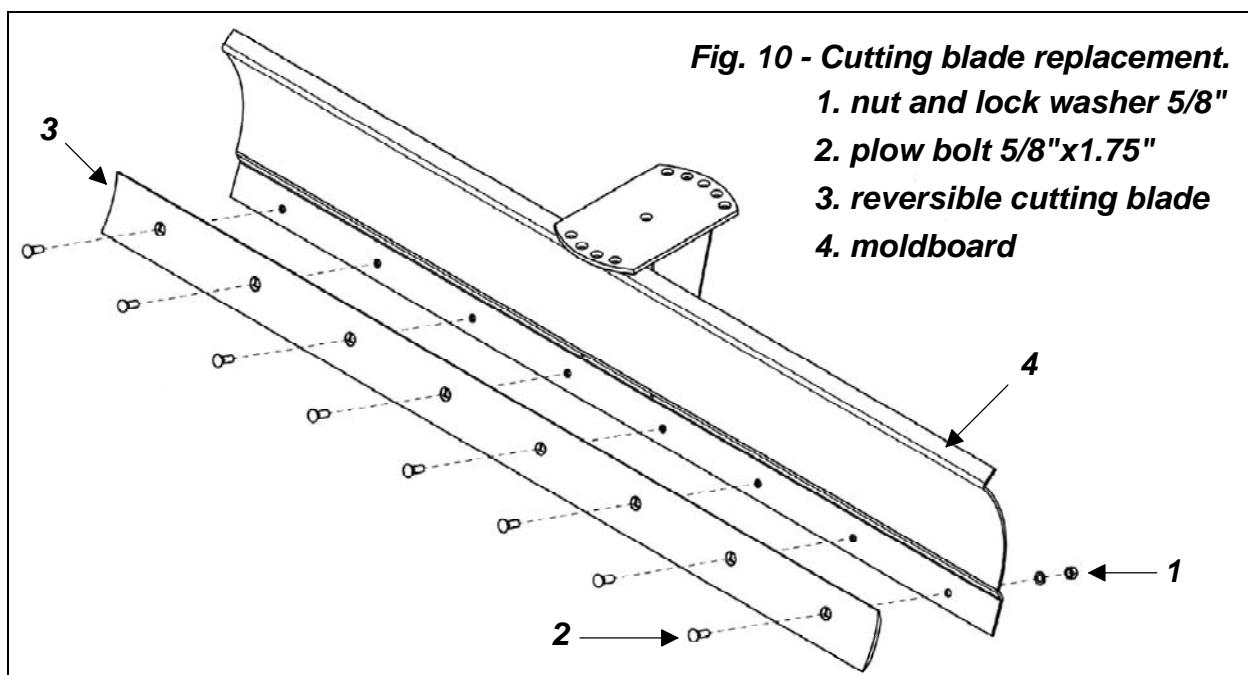

Our scraper blades are reversible. They may be rotated to give a fresh cutting edge.

To remove the blades proceed as follows (**see fig. 10**):

1. Properly support the implement using blocks to support the side plates.
2. Remove the nuts from the plow bolts and turn the blade over.
3. Inspect nuts and bolts and replace them with 5/8"-11x1.75" grade 5 plow bolts if necessary.

4. Reinstall the blade using 5/8" lock washers and 5/8" nuts and properly torque the nuts to 150 ft.lb.



CAUTION: Cutting blades are heavy and you may require assistance to remove and install them.

5.02 - Suggested Spare Parts

It is suggested that the following spare parts be kept on hand for the implement at all times to prevent a minor problem from delaying work.

Description	Quantity
Cutting blade	1
Blade plow bolts, nuts & washers	7 - 8

5.03 - Storage

After seasonal use it is important to perform the following for prolonged storage:

1. Wash the implement carefully.
2. Inspect the implement and replace worn or damaged parts.
3. Tighten all hardware⁹.
4. Grease all areas indicated under Maintenance¹⁰.
5. Apply a thin layer of grease to moldboard and cutting blade to prevent them from rusting.
6. Cover the implement from the elements in order to have it in perfect condition for the start of the next season.



WARNING: Be sure to store the implement on a hard level surface and away from people especially children.

⁹ See Table 1, page 23.

¹⁰ See Chapter 4 - Maintenance.

6 - TROUBLESHOOTING



WARNING: Be sure tractor engine is off, parking brake is locked, and key is removed before making any adjustments.

PROBLEM	POSSIBLE CAUSE	SOLUTION
Cutting blade won't penetrate the ground surface.	Soil condition is extremely packed. Tractor's top link not adjusted properly. Blade may be worn.	Lengthen tractor's top link to increase tine penetration. Adjust tractor's top link, see paragraph 3.07 - Operating Techniques. Reverse or replace cutting blade, see paragraph 5.01

7 - PRE-DELIVERY CHECKLIST

To the dealer: Inspect the machine thoroughly after assembly to assure it is functioning properly before delivering it to the customer. The following checklist is a reminder of points to cover. Check off each item as it is found satisfactory or after proper adjustment is made.

- Guards and shield properly fastened.
- Lubrication of grease fittings.
- All hardware properly tightened.
- All decals properly located and readable (**see fig. 3**).
- Blade properly installed, bolts and nuts tightened.
- Overall condition (touch up scratches, clean and polish).
- Test run, check for excessive vibration or overheating of bearings.
- Operator's Manual.

Review the Operator's Manual with the customer. Explain the following:

- Warranty.
- Safe operation and service.
- Correct machine installation and operation.
- Daily and periodic lubrication, maintenance and inspections.
- Troubleshooting.
- Operational procedures and storage.
- Parts and service.
- Fill out the Pre-Delivery Checklist and Warranty Registration form.
- Give customer the Operator's Manual and encourage the customer to read the manual carefully.

IMPORTANT: Warranty is not valid unless Pre-Delivery Checklist and Warranty Registration form in Operator's Manual is completed in detail and mailed to the Company.

Model Number: _____

Serial Number: _____

Delivery Date: _____

Dealer's Signature: _____

8 - WARRANTY

BEFCO's responsibility will be limited to substitution of the acknowledged defective merchandise to the same place of delivery as the previous one was supplied.

1. LIMITED WARRANTY

BEFCO, Inc. herein referred to as the Company, warrants its machines and related accessories, hereafter referred to as the Machine, to be free from defects in material and workmanship, for a period of twelve (12) months from the date of invoice to the first registered owner; this limited warranty does not apply to common wear items and excludes belts, shear pins, oil, grease, tires, tubes, hydraulic hoses, knives and PTO shafts.

Labor will be reimbursed at \$40.00 per hour based on BEFCO's time schedule.

Cost of transport to the servicing dealer is the responsibility of the customer.

Warranty coverage shall not be transferable from the first owner to any subsequent owner.

2. DISCLAIMER OF ALL OTHER WARRANTIES AND REMEDIES

Neither the Company nor any company affiliated with the Company makes any warranties, representations or promises, expressed or implied, as to the quality, performance or application of its products other than those set forth herein and does not make any implied warranty of merchantability or fitness.

The only remedies the purchaser has in connection with the breach, or performance of any warranty on the Company's Machine are those set forth herein. In no event will the dealer, the Company, or any company affiliated with the Company, be liable for:

- a. Injuries or damages of any kind or nature, direct, consequential or contingent to person or property.
- b. Any expenses incurred by the owner to repair, replace or rework any allegedly defective item.
- c. Any loss, cost, forfeiture or damages (including loss of profits; loss of crops; loss because of delay in field operations; any expenses or loss incurred for labor, supplies, substitute machine rental; liabilities of the owner to its customers or third persons; and all other consequential damages, losses, liabilities or damages for any other reasons) whether direct or indirect, and whether or not resulting from or contributed to by the default or negligence of the Company, its agents, employees and subcontractors which might be claimed as a result of the use or failure of the equipment delivered.

The Company's liability based on this limited warranty or any other applicable laws shall be limited to replacement or refund of the purchase price of the product.

The limited warranty extended herein gives you specific rights and you may also have other rights which vary from state to state. Neither the dealer nor the Company personnel has the authority to make any representation or to modify the terms and limitations of this warranty in any way.

Other than the limited warranty extended hereby there is no other expressed warranty in connection with the design, safety or use of any of the Company's products except as to title. All implied warranties are expressly disclaimed pursuant to the terms of this warranty.

3. CUSTOM WORK

If the Machine is used for commercial purposes such as custom work, the period warranted for the Machine is limited to six (6) months from the date of delivery to the first registered owner and does not cover any labor charges incurred.

4. RENTAL

If the Machine is used for rental purposes the period warranted for the Machine is limited to thirty (30) days from the date of delivery to the first registered owner and does not cover any labor charges incurred.

5. REGISTRATION

In order to qualify for coverage on this limited warranty, the product and name of the original purchaser must be registered with the Company by a completed Machine Pre-Delivery Checklist and Warranty Registration along with a copy of the dealer's invoice to the first registered owner to the Company within fourteen (14) days after the date of delivery to the original purchaser.

6. WARRANTY SERVICE

Warranty Service must be performed by a dealer authorized by BEFCO. If the warranty service requested is approved, the owner shall pay only for labor beyond the rate allowed, for overtime labor, and for any mileage charge for transporting the equipment to and from the dealer's shop. It is assumed that the dealer has the appropriate general and special tools to service the machine. Time required for replacement of knives, oil, grease and to remove excessive dirt from the Machine is not subject to reimbursement by the Company. The owner is required to clean the Machine before presenting it to the dealer for service work. The Machine must be delivered within thirty (30) days after failure date by the owner to the dealer to be eligible for warranty consideration.

7. UNAPPROVED SERVICE OR MODIFICATION

All obligations of the Company under this limited warranty shall be terminated if:

- a. Proper service and operation instructions as outlined in the Operator's Manual and on the instruction sticker on the Machine, are not followed.
- b. The Machine is modified or altered in any way not approved by the Company.
- c. The Company does not receive a copy of the dealer's invoice to the first registered owner within fourteen (14) days from the date of delivery.
- d. The Company has not been paid in full, by the dealer, for the Machine.

8. ACCIDENTS AND NORMAL MAINTENANCE

This limited warranty covers defective material and workmanship. It does not cover depreciation or damage caused by normal wear, accidents, improper maintenance, improper protection or improper use. The costs of normal maintenance or repairs for accidents or improper use, and related labor will be borne by the owner.

9. REPLACEMENT PARTS

BEFCO, Inc. warrants replacement parts to be free from defect in material and workmanship for a period of thirty (30) days from the date of delivery to the original purchaser.

WARRANTY REGISTRATION

BEFCO, Inc.
P.O. Box 6036
Rocky Mount, NC 27802-6036

Tel: (252) 977.9920 - Fax: (252) 977.9718

Dealer _____ Acct. # _____	Retail Customer _____
Street _____ Country _____	Street _____
Town _____ State _____ Zip _____	Town _____ State _____ Zip _____
Date of delivery _____ Invoice # _____	Phone _____
Model # _____ Serial # _____	
<p>Pre-Delivery Checklist:</p> <p><input type="checkbox"/> Greased fittings.</p> <p><input type="checkbox"/> Safety guards in place.</p> <p><input type="checkbox"/> All hardware tight.</p> <p><input type="checkbox"/> Bolts torqued correctly.</p> <p><input type="checkbox"/> Attached unit to tractor. Yes/No.</p> <p><input type="checkbox"/> Field adjusted. Yes/No.</p> <p><input type="checkbox"/> Test run. Dry/Infield.</p> <p><input type="checkbox"/> Safety decals.</p> <p><input type="checkbox"/> Operator's Manual.</p> <p>The machine described above, had been prepared for delivery according to the Pre-Delivery Checklist and the Customer has been instructed in its care and operation and the condition of warranty.</p>	<p>Tractor make: _____</p> <p>Model: _____; HP _____</p> <p>Type of operation: Private homeowner, Landscaping, Commercial maintenance, Golf Course, Municipality, Turf Farm, others: _____</p> <p>Approximate number of acres machine will be used on annually: _____</p> <p>I hereby acknowledge that: I have received and accepted delivery of the machine described. The equipment was checked thoroughly for loose or missing parts and has been adjusted in accordance with the Pre-Delivery Checklist. I have read and understand the nature and extent of the warranty and understand clearly that there were and are no other representations of warranties either expressed or implied, made by anyone. I have been advised on proper operation, maintenance and lubrication procedure of this equipment. I have been instructed on and do understand the application, limitation and capacities this equipment was designed and recommended for, all as described in the Operator's Manual and literature published by the Company.</p>
Inspected by: _____	
Date: _____	Date: _____
Dealer's Signature: _____	Customer's Signature: _____

This registration along with a copy of the invoice must be sent to BEFCO, Inc. within 14 days of date of purchase.

Sender:

Fold here

*Place stamp
here*

BEFCO, Inc.

Warranty Department

P.O. Box 6036

Rocky Mount, NC 27802-6036

Cut along this line



BEFCO®

Parts Manual

GROUND ENGAGE EQUIPMENT

Heavy Duty Rear Blades

BRB-284, BRB-296

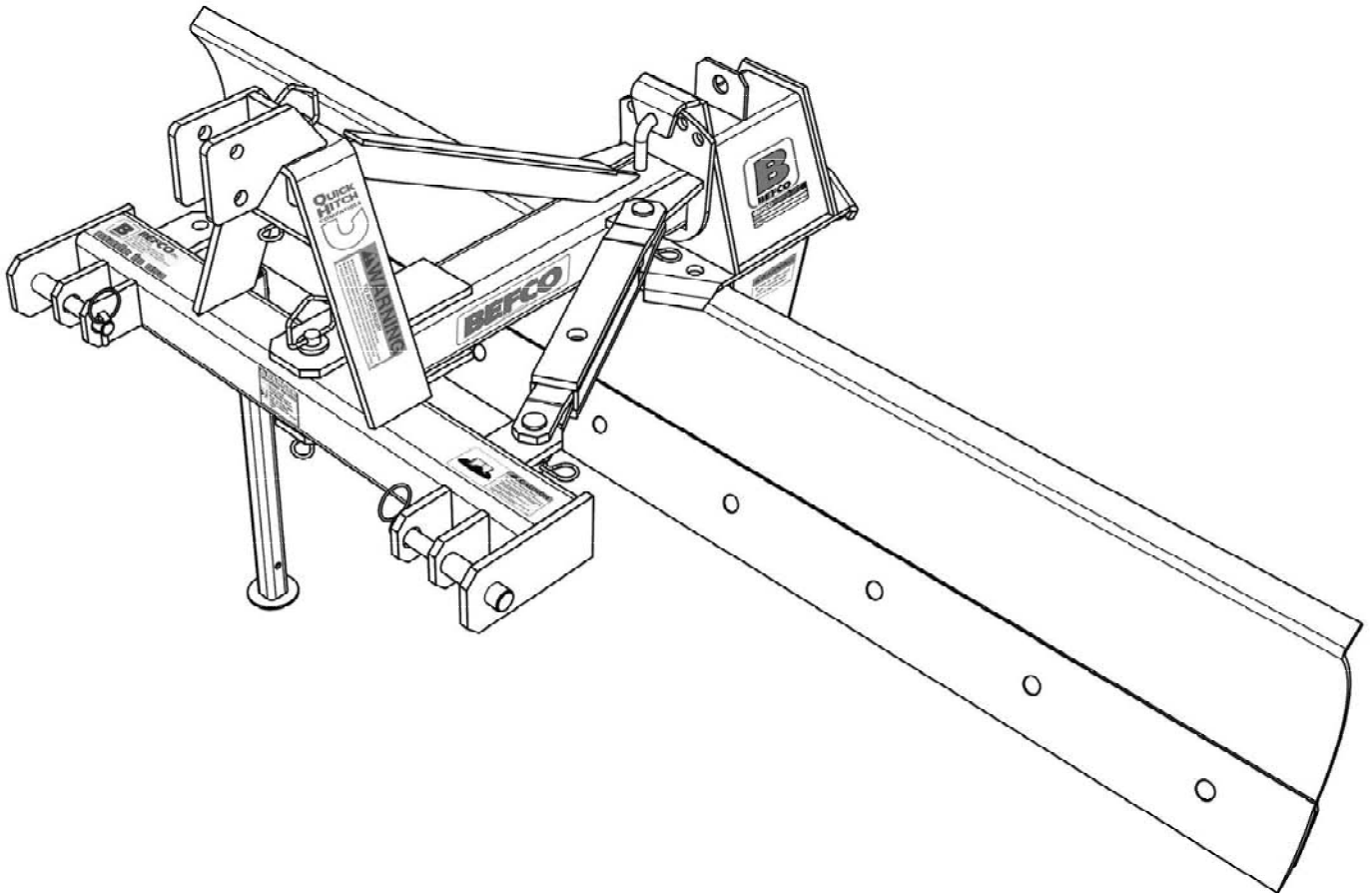

Ref.	Part #	Description	Qty.
1	503-671B	HD Hitch A-frame; #279555 & below	1
	7900081	HD Hitch A-frame; #279556 & above	1
2	503-672B	HD Hitch rear frame; #279555 & below	1
	7900082	HD Hitch rear frame; #279556 & above	1
3	503-673B	Swivel box	1
4	503-674B	Swivel box cap	1
5	503-677B	Mold board BRB-284; #279555 & below ¹¹	1
	7900080	Mold board BRB-284; #279556 & above	1
	503-712B	Mold board BRB-296; #279555 & below ¹²	1
	7900090	Mold board BRB-296; #279556 & above	1
6	046-9019	Scraper blade BRB-284	1
	066-9019	Scraper blade BRB-296	1
7	503-675B	Adjustment brace male; #279555 & below	1
	7900083	Adjustment brace male; #279556 & above	1
8	503-676B	Adjustment brace female; #279555 & below	1
	7900084	Adjustment brace female; #279556 & above	1
9	503-651B	Bolt PB 5/8"-11X1.75" G5 Z	-
10	502-866B	Washer, lock 5/8" Z	-
11	502-865B	Nut HH 5/8"-11 Z	-
12	009-1507	"R" clip Ø4	5
13	503-679B	Foot stand	1
14	006-9510	Bolt HH 1/2"-20x1.25" G5 Z	4
15	190-2056	Washer, lock 1/2" Z	4
16	006-9511	Bolt HH 1"-8x2.25" G5 Z	1
17	006-9513	Washer, flat 1" Z	1
18	006-9507	Hitch pin cat. 1 - cat. 2	2
19	001-8266	Lynch pin 11x45	2
20	006-9506	Flat head pin 1"x3 5/16"	4
21	501-684B	Lock pin 3/8"x2.5"	1
22	006-9514	Handle pin 6.88"	1
23	006-9508	Handle pin 7.75"	1
24	501-657B	"R" clip Ø5	2
25	006-9400	Skid shoe (option)	2
26	503-650B	Bolt PB 5/8"-11x2" G5 Z (option)	4
27	503-972B	Stroke control (option)	1
28	502-170B	1/2" Quick connector nipple 1/2" fp (option)	2
29	503-880B	90° Elbow 3/8" (option)	1
30	502-414B	90° Elbow 3/4" O-ring (option)	1
31	503-714B	Hydraulic hose 72" (option)	2
32	002-9286	Block pin 3.5"	1
33	503-033B	Hydraulic cylinder (option)	1
	502-756B	Repair kit for cylinder 503-033B	-
34	001-8010	Bushing cat.1-2 (option)	1

¹¹ Moldboard interchangeable with part #7900080.

¹² Moldboard interchangeable with part #7900090.

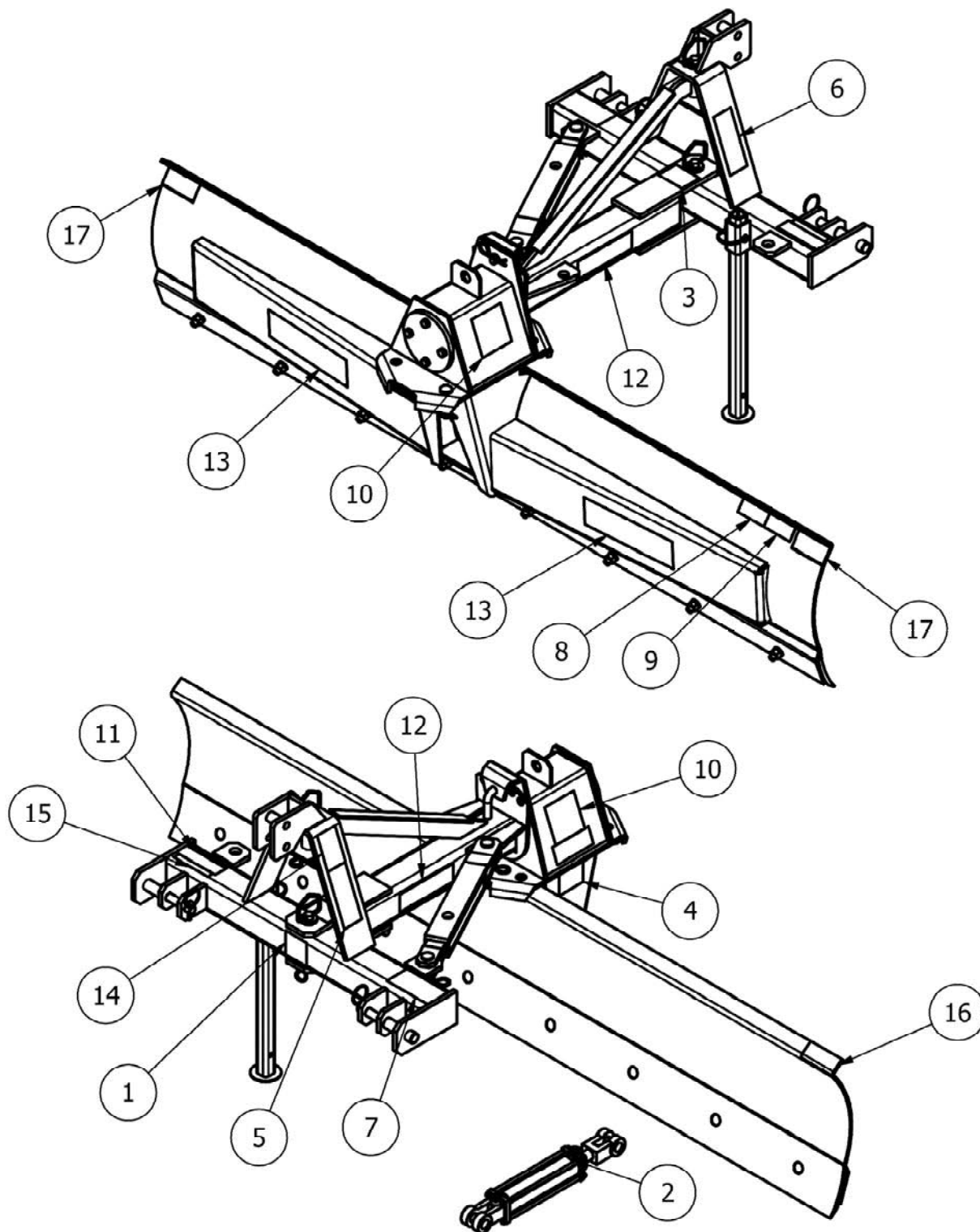

Ref.	Part #	Description	Qty.
1	950-321B	Decal "DANGER - Crushing hazard"	1
2	950-408B	Decal "WARNING - High pressure hydraulic oil leaks"	1
3	950-322B	Decal "WARNING - Pinch point"	1
4	950-323B	Decal "WARNING - Tighten pivot point"	1
5	950-319B	Decal "WARNING - To avoid injury"	1
6	950-320B	Decal "WARNING - To avoid injury, storage"	1
7	950-210B	Decal "CAUTION - Read operator's manual"	1
8	950-813B	Decal "BRB"	1
9	950-248B	Decal "284"	1
	950-345B	Decal "296"	1
10	950-103B	Decal "B" logo	2
11	950-381B	Decal "BEFCO INC" address	1
12	950-106B	Decal "BEFCO" small	2
13	950-107B	Decal "BEFCO" medium	2
14	950-940B	Decal "Quick Hitch Compatible"	1
15	950-358B	Decal "Made in USA"	1
16	950-405B	Yellow reflective decal	1
17	950-366B	Red reflective decal	2
	971-210B	Operator's & Parts Manual BRB-284, BRB-296	1

Use only original spare parts

All rights reserved. It is unlawful to copy, reprint or use any of the information or details in this manual without the expressed written permission of the Company. Technical information provided in this manual is approximate, the Company reserves the right to modify or improve the models shown for technical or commercial purposes. Pictures in this manual do not necessarily show the machine as delivered.

BEFCO[®]

P.O. Box 6036
Rocky Mount, NC 27802-6036
Tel.: 252.977.9920 - Fax: 252.977.9718
www.befco.com

