

**BEFCO**

# OPERATOR'S MANUAL

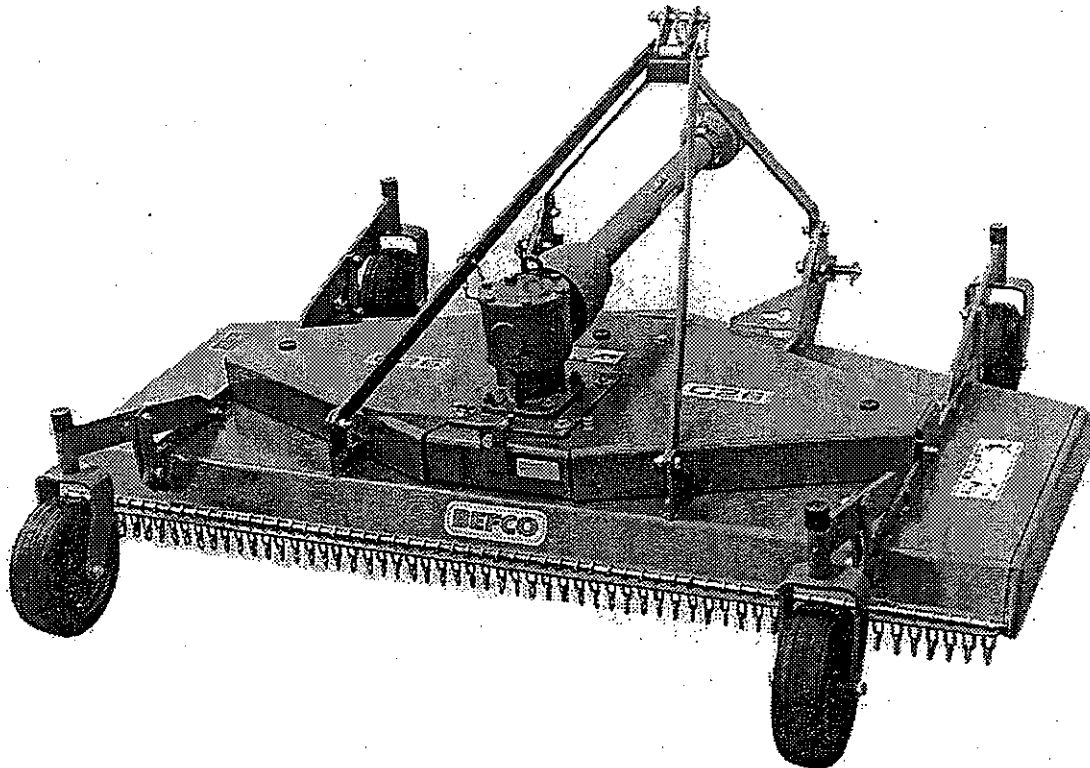

## SERIES 2 FINISHING MOWER

# INTRODUCTION

Read this manual carefully. It will instruct you on how to operate and service your machine safely and correctly. Failure to do so could result in personal injury and/or equipment damage.



This SAFETY-ALERT symbol means **ATTENTION! BE ALERT!**  
YOUR SAFETY IS INVOLVED!

When you see this symbol, be alert to the possibility of serious bodily injury or death. Carefully follow the instructions in the safety message.

This machine is of metric design. However, for your convenience, most specifications are given in metric measurements with the customary U.S. measurements following.



**CAUTION: All hardware is metric. Only metric tools should be used. Other tools that do not fit properly can slip and cause injury.**

Right-hand and left hand sides of the implement are determined by facing in the direction the implement will travel when going forward.

Warranty is provided for customers who operate and maintain their equipment as described in this manual. Warranty registration is accomplished by the dealer completing and forwarding the WARRANTY REGISTRATION FORM along with a copy of the dealer's invoice to BEFCO, Inc. It is in your best interest to insure that this has been done.

BEFCO's warranty does not cover the following:

- 1) Cleaning, transporting, mailing and service call charges.
- 2) Normal wear items such as belts, blades, bearings, etc.
- 3) Depreciation of damage caused by normal wear, accidents, improper maintenance, improper protection or improper use.

See Complete Warranty found on the inside back cover.

Your authorized BEFCO Dealer has in stock genuine BEFCO parts. Only these BEFCO-approved replacements should be used.

Record your implement model and serial number in the space provided below. Your dealer needs this information to give you prompt, efficient service when you order parts.

MODEL NO. \_\_\_\_\_

SERIAL NO. \_\_\_\_\_

DATE PURCHASED \_\_\_\_\_

# DEALER CHECKLIST

To The Dealer:

Inspect the implement thoroughly after assembly to be certain it is functioning properly before delivering it to the customer. The following checklist is a reminder of points to cover. Check off each item as it is found satisfactory or after proper adjustment is made.

## PREDELIVERY CHECKLIST

- |   |  |
|---|--|
| <input type="checkbox"/> 1. Gear case oil level and seals                     | <input type="checkbox"/> 7. Other adjustments for machine level, height, etc.            |
| <input type="checkbox"/> 2. Guards and shields properly fastened              | <input type="checkbox"/> 8. Overall condition (touch up any scratches, clean and polish) |
| <input type="checkbox"/> 3. Lubrication of grease fittings                    | <input type="checkbox"/> 9. Test run for about one minute, check for excessive vibration |
| <input type="checkbox"/> 4. All hardware properly tightened                   | <input type="checkbox"/> 10. Operator's manual   |
| <input type="checkbox"/> 5. All decals properly located and readable          |  |
| <input type="checkbox"/> 6. Blades and belts properly installed and tightened |  |

DATE SET UP \_\_\_\_\_

SIGNATURE \_\_\_\_\_

# DELIVERY

Review the operator's manual with the customer. Explain the following:

- 1. BEFCO warranty
- 2. Safe operation and service
- 3. Correct machine installation and operation
- 4. Daily and periodic lubrication and maintenance
- 5. Correct lubricants
- 6. Daily and periodic inspections
- 7. Trouble shooting
- 8. Removing and storing machine
- 9. BEFCO parts and service
- 10. Have the customer write the machine model and serial number in space provided in manual introduction
- 11. Give customer the operator's manual and encourage the customer to read the manual carefully
- 12. Remove and file this page

Warranty is not valid unless Registration Form in Operator's Manual is completed in detail and mailed to Befco, Inc., P.O. Box 6036, Rocky Mount, N.C., 27802

DATE DELIVERED \_\_\_\_\_

SIGNATURE \_\_\_\_\_ (Dealer)

SIGNATURE \_\_\_\_\_ (End User)

Model No. \_\_\_\_\_

Serial No. \_\_\_\_\_

# DESCRIPTION

The Series 2 Cyclone Mower is designed for commercial use. The mower is available in 3 different sizes which are four, five and six feet. The mowers are engineered to be used on 15 to 50 PTO horsepower tractors with category I hitches.

The cyclone's floating hitch design allows the mower to follow the ground contour. Blade spindles are driven by two V-belts and large diameter cast iron pulleys which produce greater torque and durability.

# CONTENTS

## Section I

Safety Precautions .....	6, 7, 8
--------------------------	---------

## Section II Owner/Operator Instructions

Preparing the Tractor .....	8
Preparing the Machine .....	8, 9
Attaching the Machine .....	9
Operating the Machine .....	10, 11, 12
Transporting and Detaching .....	14
Storage .....	14
Lubrication and Maintenance .....	15, 16, 17, 18
Troubleshooting .....	19

## Section III Parts

Main Frame .....	20, 21, 22, 23
Gearbox .....	24, 25
Rotor & Blade .....	26, 27
PTO .....	28, 29

## Section IV

Assembly .....	30, 31, 32
Specifications .....	33
Delivery and Warranty Registration .....	37
Warranty .....	Inside Back Cover

# SAFETY

## OBSERVE SAFETY SIGNS

**DANGER:** This message denotes the most serious specific potential hazard. The sign will have the color combination of **red and white**.



**CAUTION:** This message denotes a reminder of safety practices. The sign will have the color combination of **yellow and black**.



**WARNING:** This message denotes a specific potential hazard. The sign will have the color combination of **yellow and black**.



Carefully read and follow all safety signs. Reinstall safety signs that are damaged or missing.

 <b>KEEP AWAY!</b> Rotating <b>DRIVELINE</b>	<b>WARNING</b> <b>AVOID INJURY FROM PTO</b> <ul style="list-style-type: none"> <li>• Entanglement can cause serious injury or death</li> <li>• Keep driveline shields in place &amp; in good condition</li> <li>• Keep hands, feet, and clothing away</li> <li>• Operate only with 540 RPM</li> </ul>
--	--

<b>DANGER</b>  <b>ROTATING DRIVELINE</b> CONTACT CAN CAUSE DEATH <b>KEEP AWAY!</b> DO NOT OPERATE WITHOUT — • ALL SHIELDS, PROTECTIVE AND EQUIPMENT SHIELDING IN PLACE • SHIELDS SECURELY ATTACHED TO BOTH SHAFTS • SHIELDS SHIELDING THAT TRAP FINGER OR LIMB
--

<b>DANGER</b>  <b>ROTATING BLADE</b> DO NOT CUT HAIR OR FEET UNDER OR INTO ANY PART OF THE MOWER OR OTHER BLADES IS ROTATING OR ENGINE RUNNING
---

<b>WARNING</b> <b>AVOID BODILY INJURY</b> <ul style="list-style-type: none"> <li>• READ OPERATOR MANUAL with all safety procedures</li> <li>• Use regulations and labels at control</li> <li>• Keep all shields &amp; guards in place</li> <li>• Stay out of powertrain parts</li> <li>• Never carry loads</li> <li>• Use proper methods &amp; safe distance away from blade</li> <li>• Always wear clear view of objects that may be thrown by blades</li> <li>• Use PTO clutch at all times when using discharge deflector</li> </ul> <b>BEFORE DISMOUNTING OR SERVICING</b> <ul style="list-style-type: none"> <li>• Shut off engine and disconnect battery</li> <li>• Lock or block the mower</li> </ul>
---

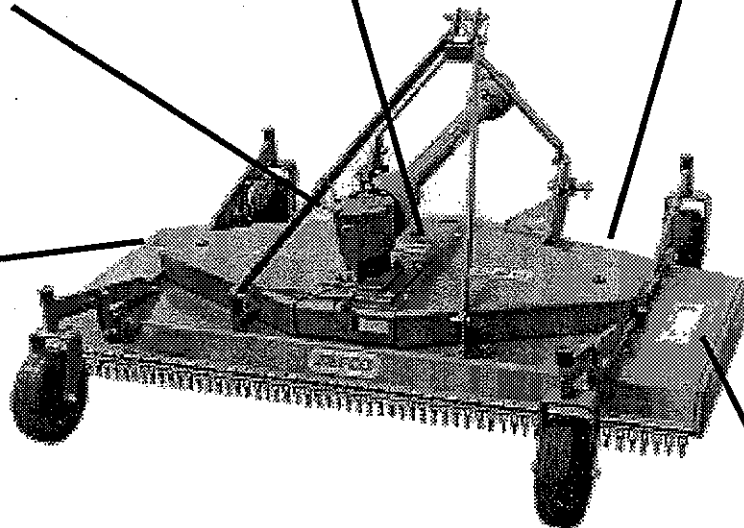

 <b>DANGER</b> <b>ROTATING BLADE</b> DO NOT CUT HAIR OR FEET UNDER OR INTO ANY PART OF THE MOWER OR OTHER BLADES IS ROTATING OR ENGINE RUNNING • THROWN OBJECTS DO NOT OPERATE IN VICINITY OF OTHER PERSONS CLEAR AREA OF OBJECTS IN ALL DIRECTIONS NEVER OPERATE WITHOUT DISCHARGE DEFLECTOR	
---	--

# SAFETY, cont.

## LEARN MACHINE SAFETY

Carefully read this manual. Learn how to operate the machine safely.

Do not let anyone operate this machine without proper instruction.

Unauthorized modification to the machine may impair the function and/or safety of the machine and reduce machine life.

## STAY CLEAR OF ROTATING DRIVELINE

Entanglement in rotating driveline can cause serious injury or death. Disengage PTO, engage parking brake or place transmission in "PARK", shut off the tractor and remove the key before:

- Working around hitch
- Attaching or detaching driveline
- Making adjustments or servicing the machine
- Cleaning the machine

## PROTECT CHILDREN AND BYSTANDERS

**NEVER** operate the machine near people or pets.

**DO NOT** stand near the machine while the blades are spinning. Debris can be thrown hundreds of feet.

**DO NOT** allow children to ride on the machine, tractor, or any attachment.

**DO NOT** allow children to operate tractor or machine.

## KEEP RIDERS OFF MACHINE

Allow only the operator on the machine. Keep riders off. Riders are subject to injury and obstruct the operator's view.

## INSPECT MOWER REGULARLY

Check for loose hardware, especially blades and blade holder locknuts.

## OPERATE TRACTOR AND MOWER SAFELY

Keep all guards and shields in place.

Keep hands, feet and clothing away from the mower deck when the blades are turning.

Use proper ballast and weights for your make and model of tractor.

Clean the work area of objects that might be picked up and thrown by the mower blades.

Disengage the mower and carefully look behind the mower before backing up.

Shut off tractor engine and remove the key before adjusting, servicing, cleaning or inspecting the cutter.



**CAUTION: DO NOT OPERATE THE TRACTOR AND MOWER WHEN YOU ARE TIRED OR WHEN USING MEDICATION. PERSONAL INJURY OR DEATH CAN OCCUR.**

Observe the type of terrain and develop a safe cutting pattern. Do not cut under any condition where traction or stability is doubtful without first test driving over the terrain with the PTO disengaged and mower in the down position.

# SAFETY, cont.

## TRANSPORT TRACTOR AND MOWER SAFELY

Disengage PTO.

Fully raise machine and lock rockshaft control lever.

Beware of traffic on public roads.

## PRACTICE PERSONAL SAFETY

Wear safety equipment and fairly tight clothing.

Use only during daylight hour.

# PREPARING THE TRACTOR

## TRACTOR REQUIREMENTS

1. The "Cyclone" mower can be used with tractors up to 50 PTO horsepower.



**IMPORTANT: TRACTOR ENGINE SPEED MUST ALWAYS BE SET SO THAT THE PTO SPEED DOES NOT EXCEED 540 RPM.**

2. Tractor must be equipped with a category 1- 3 pt. hitch and should have stabilizing chains or a similar device to control mower side sway.
3. On some tractors, it may be necessary to shorten remove or position to one side the drawbar to prevent interference with the driveline.
4. Adjust right and left hand lower draft links to the same height.

5. To insure proper stability, adjust ballast, wheel spacing and tire inflation according to tractor operator's manual.



**IMPORTANT: TRACTOR FRONT END STABILITY IS NECESSARY FOR SAFE OPERATION WHEN USING 3 PT. MOUNTED EQUIPMENT. REFER TO YOUR TRACTOR OPERATOR'S MANUAL OR SEE YOUR DEALER TO FIND THE REQUIRED AMOUNT OF FRONT END BALLAST.**

# PREPARING THE MACHINE

## OPERATOR'S RESPONSIBILITIES

- Safe and correct operation of this machine.
- Before operating mower be familiar with all mower/tractor controls and their function.
- Proper inspection, lubrication and maintenance.

- Read this manual carefully in order to understand the safe and correct operation procedures.
- Observe all safety precaution decals on the machine and highlighted throughout the manual.



# PREPARING THE MACHINE cont.

## GETTING READY TO MOW

With the engine off and key removed from the ignition:

- Check the condition of blades. Tighten, sharpen, or replace the blades as required.
- Check to ensure that the cutting edge is positioned in the direction of blade rotation (See Installing Blades pg. 16).
- Check blades and spindles for any wrapped objects such as wire or steel bands that need to be removed.

-Inspect tractor for proper tire air pressure and front and rear ballast. Refer to tractor operator's manual.

- Check that mower discharge deflector, PTO shield and belt shields are properly fastened.
- Raise and lower machine to make sure PTO does not bottom out and has a minimum of 3" overlap when extended.

## ATTACHING THE MACHINE

### CONNECTING THE DRAFT LINKS AND CENTER TOP LINK

**CAUTION: MAKE SURE NO ONE IS BEHIND MOWER OR BETWEEN TRACTOR AND MOWER WHILE ATTACHING.**

1. Back tractor up to mower until draft links align with hitch pins.
2. Secure draft links to hitch pins using quick lock pins.



**CAUTION: SHUT OFF ENGINE, REMOVE KEY AND ENGAGE PARKING BRAKE BEFORE WORKING AROUND HITCH.**

3. Attach center top link to hitch mast with headed mast pin and quick lock pin.
4. Adjust sway chains if necessary to center mower behind tractor and to control mower side sway.

### CONNECTING DRIVELINE

1. Press in pin (A) and turn yoke to align with spline on tractor PTO shaft (B).
2. Push driveline forward until pin (A) snaps into locked position.
3. **IMPORTANT:** Move driveline back and forth on PTO to be sure it is locked.

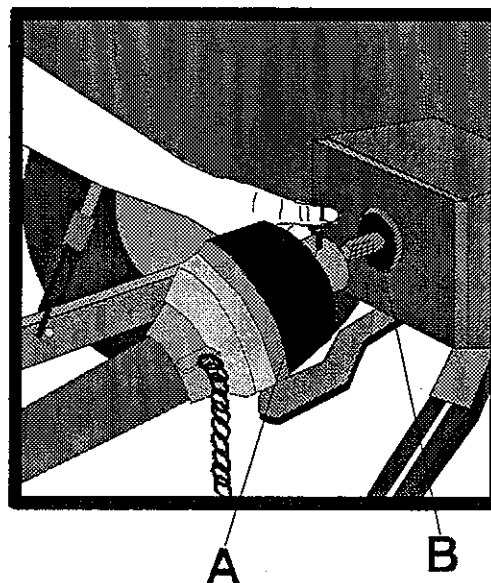

# OPERATING THE MACHINE

## ADJUSTING CUTTING HEIGHT

The cutting height can be adjusted to one of twelve positions. This is the distance between the blades and the ground. The positions range from 1" to 6 1/2" and are controlled by the four adjustable caster wheels.

1. Lift the mower using the tractor's rock shaft control lever.



**WARNING: STOP ENGINE, REMOVE KEY AND APPLY PARKING BRAKE BEFORE MAKING ANY ADJUSTMENTS.**

2. Put blocks or support stands under mower deck.

### CUTTING HEIGHT ADJUSTMENT:

3. BEFCO current series 2 finishing mowers features multiple cutting height adjustment. On each wheel support arm there are 3 primary position holes provided. On each wheel yoke spindle there is a 1" and 1/2" spacer.

Counting from the deck outward; primary hole position #1 on the wheel support arm is the 1" cutting position, hole #2 is 3" cut, and hole #3 is 5" cut. By utilizing the 1" and 1/2" spacers you can fine tune the primary cutting heights by 1/2" increments.

**EXAMPLE:** Wheel arm in #1 position with 1/2" spacer placed on the bottom of yoke spindle will place the cutting height at 1 1/2"

PRIMARY HOLE POSITION	SPACER POSITION	DECK CUTTING HEIGHT
#1	BOTH ON TOP	1"
#1	1/2" ON BOTTOM	1 1/2"
#1	1" ON BOTTOM	2"
#1	BOTH ON BOTTOM	2 1/2"
#2	BOTH ON TOP	3"
#2	1/2" ON BOTTOM	3 1/2"
#2	1" ON BOTTOM	4"
#2	BOTH ON BOTTOM	4 1/2"
#3	BOTH ON TOP	5"
#3	1/2" ON BOTTOM	5 1/2"
#3	1" ON BOTTOM	6"
#3	BOTH ON BOTTOM	6 1/2"

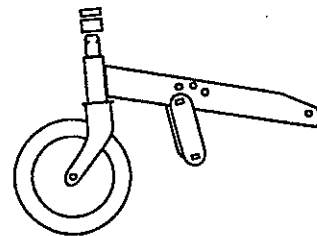

4. Be sure all wheel arms are adjusted equally in order to maintain mower level side to side and front to rear.



**IMPORTANT: VERY LOW CUTTING HEIGHTS SHOULD BE AVOIDED. DAMAGING SHOCK LOADS OCCUR WHEN THE BLADES STRIKE THE GROUND REPEATEDLY. THIS CAN CAUSE DAMAGE TO THE MOWER.**

5. Be sure to retighten both bolts on each wheel arm once the desired cutting height has been established.

# OPERATING THE MACHINE, cont.

## ADJUSTING TRACTOR TOP LINK

Adjust tractor top link to allow the mower to follow the ground contour and yet remain as level as possible when raised to transport position. When lowered in working position, the mower's top hitch plates should have approximately 1 1/2" clearance, as shown.

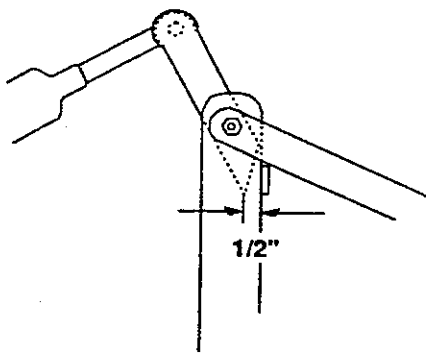

## ENGAGING MOWERS



**CAUTION: THE MOWER MUST ALWAYS BE LOWERED TO THE GROUND BEFORE STARTING TRACTOR ENGINE OR ENGAGING PTO LEVER.**



**CAUTION: TRACTOR PTO SHOULD ALWAYS BE DISENGAGED BEFORE STARTING OR STOPPING ENGINE.**

1. Lower mower to the ground with the tractor rockshaft control lever.
2. With engine idling, slowly engage the PTO drive.
3. Move the throttle lever until a PTO speed of 540 rpm's is obtained.



**CAUTION: YOUR CYCLONE MOWER IS DESIGNED TO OPERATE AT A PTO SPEED OF 540 RPM'S. SOME TRACTORS ARE EQUIPPED WITH A MULTI-SPEED REAR PTO AND MUST BE SET FOR 540 RPM. DO NOT OPERATE THE PRO ABOVE 540 RPM'S. SERIOUS DAMAGE CAN OCCUR TO THE MACHINE AND/OR THE OPERATOR.**

4. Shift the transmission to a slower speed gear and start forward travel.
5. **DO NOT** mow in reverse unless absolutely necessary and only after careful observation of the area behind the mower.



**CAUTION: THE MOWER MUST BE OVER CLEAR GROUND BEFORE STARTING ENGINE.**

## MOWING TECHNIQUE

1. For maximum cutting efficiency, always operate the tractor PTO at 540 rpm. This will maintain the constant maximum blade speed necessary for a clean cut.
2. Ground speed should be controlled by gear selection, not engine speed. All of the following factors are important in selecting the proper forward speed:
  - height of grass
  - type of grass
  - density of grass
  - type of terrain
3. Under certain conditions such as tall grass, the weight of the tractor's wheels may prevent certain grasses from being cut properly. When this occurs reduce the tractor ground speed or mow the area twice.

## OPERATING THE MACHINE, cont.

4. Mow extremely tall grass twice. On the first pass use a high cutting height. On the second pass position the mower at the desired height and when practical mow at a right angle in travel to the first pass.
5. Due to the direction of the blades' rotation, operate the mower with uncut grass to the left. Clippings will discharge over the cut area. Continued discharging of clippings over the uncut area could result in the build up of clippings.
10. Avoid tipping the mower while cutting. Watch for holes, roots or other hidden objects. Do not cut near the edge of a gully, ditch or stream bank.



**WARNING: NEVER OPERATE THE MOWER WITHOUT THE DISCHARGE DEFLECTOR PROPERLY INSTALLED. THE MOWER BLADES CAN THROW OBJECTS HUNDREDS OF FEET WHICH COULD RESULT IN PERSONAL OR PROPERTY DAMAGE.**

6. If at any time the mower should jam resulting in belt slippage of 2 or more seconds, raise the mower and continue for 2-3 minutes. This will allow the pulleys to cool and prolong belt life.
7. For cleaner cuts and more efficient mowing the blades must be kept sharp. See Sharpening Blades section for details.
8. Observe the type of terrain and develop a safe mowing pattern. Whenever traction or stability is doubtful, first test drive over the terrain with the PTO disengaged.
9. Operate the mower up and down steep slopes, not across slopes, to prevent the tractor from tipping. Avoid sudden stops and starts and slow down before changing directions on a slope.

# NOTES

# TRANSPORTING AND DETACHING

## TRANSPORTING MOWER



**CAUTION: MAKE SURE PTO IS DISENGAGED AND BLADES HAVE STOPPED TURNING BEFORE RAISING MOWER TO FULL TRANSPORT POSITION.**

1. Disengage PTO
2. Fully raise machine and lock rockshaft control lever.
3. Lock both tractor brakes together.
4. Always select a safe ground speed that is appropriate for the terrains.
5. Beware of traffic on public roads. Install a SMV (Slow Moving Vehicle) sign when traveling on roads or streets.
6. Reduce ground speed when turning and take care that the mower does not strike obstacles such as trees, fences or buildings.



**CAUTION: DO NOT TOW TRACTOR AND MOWER BEHIND OTHER VEHICLES. USE A PROPERLY EQUIPPED TRAILER WITH HEAVY TIE-DOWNS FOR TOWING OPERATIONS.**

## DETACHING MOWER



**DANGER: ENTANGLEMENT IN ROTATING DRIVELINE CAN CAUSE SERIOUS INJURY OR DEATH. DISENGAGE THE PTO, LOCK PARKING BRAKE, SHUT OFF ENGINE AND REMOVE KEY BEFORE DETACHING THE DRIVELINE.**

1. Support driveline and push pin (A) to unlock driveline from PTO (B).
2. Pull driveline rearward off PTO (B).
3. Detach hitch top link.
4. Disconnect draft links from the mower's hitch pins.

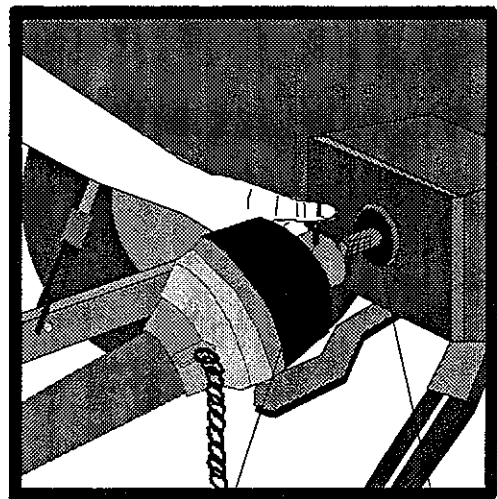

A

B

## STORAGE

1. Detach mower from tractor.
2. Use a hand scraper and/or water to remove debris from underside of mower deck.
3. Check blade wear. Sharpen blades if necessary (refer to sharpening blades section for details).
4. Remove belt shields and clean belt area thoroughly.
5. If mower is to be stored for a long time, loosen the belts (refer to replacing belts section to loosen belts).
6. Restore or replace any damaged parts and apply touch up paint where needed to prevent rust.
7. Mower should be stored in a clean and dry place.

# LUBRICATION AND MAINTENANCE



**IMPORTANT: THE LUBRICATION PERIODS RECOMMENDED ARE BASED ON NORMAL USAGE. SEVERE OR UNUSUAL CONDITIONS MAY REQUIRE MORE FREQUENT LUBRICATION.**

## GEAR CASE OIL

Use SAE 90 weight gear lube or its equal.

## GENERAL PURPOSE GREASE

Use an SAE multi-purpose type grease to lubricate at intervals shown.

Clean fittings thoroughly before lubricating.

Replace missing or damaged grease fittings immediately.

## SERVICE/DAILY

### Mower Blades

Check the condition of mower blades for nicks or dull edges. Sharpen if necessary. Replace bent or damaged blades. See Removing Blades for details.

Also check blades for damage after hitting an obstruction.



**CAUTION: STOP ENGINE, LOCK PARKING BRAKE AND REMOVE KEY BEFORE INSPECTING OR WORKING ON BLADES. NEVER RELY ON THE TRACTOR LIFT SYSTEM. INSTALL BLOCKS OR STANDS UNDER THE MOWER DECK TO PREVENT IT FROM FALLING.**

Clean foreign material from mower deck and belt area.

### Lubricate Driveline

1. Lubricate both U-Joints with one or two shots of multi-purpose grease.

2. Lubricate driveline guard plastic fitting with one or two shots of grease.
3. Separate the front and rear driveline, brush on grease and then reassemble driveline.

### Lubricate Caster Wheels

Apply two or three shots of grease to fittings on caster wheel spindles.

### Gear Box Oil Level

1. With tractor and mower on a level surface, remove the dipstick, wipe clean and re-install.
2. Remove dipstick. Oil must be up to the mark on the dipstick. If the oil is low, add SAE 90 weight gear lube or equivalent to bring the oil to the proper level.

## SERVICE/25-HOURS

### Hardware Tightness

Mower vibration can loosen bolts. Table 1 which is found in the assembly instructions gives the correct torque values for various bolts and cap screws. Check tightness of the hardware periodically, using this table as a guide.

## SERVICE/50-HOURS

### Lubricate Blade Spindles

Lubricate the three spindles with two or three shots of multi-purpose grease.

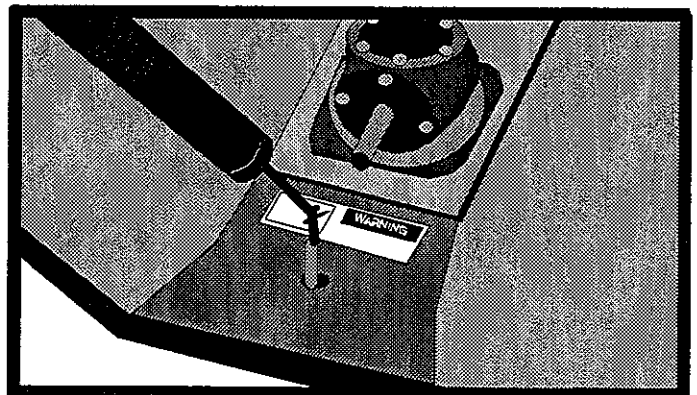

# LUBRICATION AND MAINTENANCE, cont.

## SERVICE/AS NEEDED

### Removing Blades

**CAUTION: AVOID POSSIBLE INJURY, WEAR PROPER EYE AND HAND PROTECTION WHEN SERVICING MOWERS BLADES.**

**STEP 1:** Shut off the engine, engage parking brake and remove key.

**STEP 2:** Place blocks or support stands under the mower deck.

**WARNING: NEVER TRUST A TRACTOR'S HYDRAULIC LIFT SYSTEM. USE SUPPORT STANDS OR BLOCKS TO PREVENT THE MOWER FROM FALLING. SERIOUS INJURY CAN OCCUR.**

**STEP 3:** Loosen and remove the 18mm nylon insert locknut, conical shaped washer and mower blade.

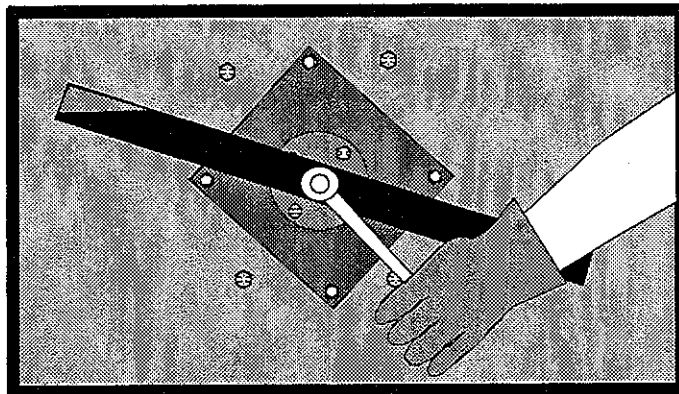

### Installing Blades

**CAUTION: AVOID POSSIBLE INJURY, WEAR PROPER EYE AND HAND PROTECTION WHEN SERVICING MOWER BLADES.**

**STEP 1:** Position the mower blade on the shaft so the cutting edge will be leading the blade rotation. The blade rotates counterclockwise when you are facing the bottom of the deck.

**STEP 2:** Fasten the blade with the 18mm conical shaped washer and 18mm nylon insert locknut. Torque the nut to 309 N-m (209 ft-lb).

**WARNING: AVOID PERSONAL INJURY OR DEATH. USE ONLY AN 18MM NYLON INSERT LOCKNUT TO HOLD THE MOWER BLADE ON THE SPINDLE SHAFT. ALSO, THE PROPER TORQUE MUST BE USED**

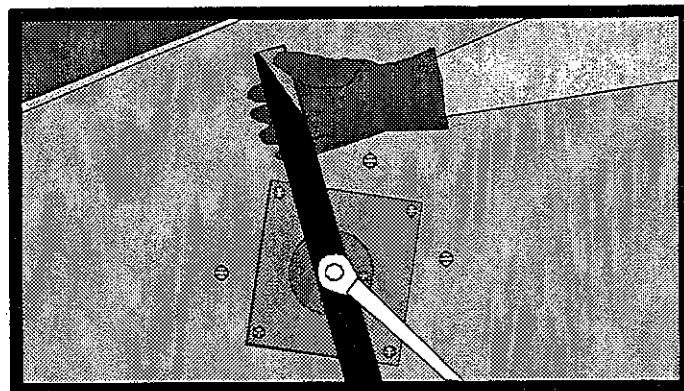

**WHEN TIGHTENING THE NUT. TORQUE THE NUT TO 309 N-M (209 ft-lb). IF THESE SAFETY PRECAUTIONS ARE NOT FOLLOWED, THE BLADE COULD COME OFF DURING OPERATION AND BE THROWN FROM THE MOWER.**

**NOTE:** The 18mm conical shaped washer fits between the blade and the nylon insert locknut.



# LUBRICATION AND MAINTENANCE, cont.

## Sharpening Blades

**CAUTION: AVOID POSSIBLE INJURY. WEAR PROPER EYE AND HAND PROTECTION WHEN SERVICING MOWER BLADES.**

Sharpen the blades by using a hand file or grinder. **DO NOT** sharpen the blades to a sharp cutting edge. The cutting edge should be between 0.4mm to 0.8mm (1/64" to 1/32") to prevent excessive pitting and dulling of the blades. Sharpen both ends of the blade equally for balance.

**CAUTION: UNBALANCED OR WARPED BLADES CAN CAUSE DAMAGE TO THE MOWER AND/OR PERSONAL INJURY. REPLACE DAMAGED BLADES BEFORE OPERATING THE MOWER. SHARPEN BOTH ENDS OF THE MOWER BLADES EQUALLY OR UNTIL THE BLADE IS BALANCED.**

**NOTE:** Contact your BEFCO Dealer if you have questions pertaining to blade sharpening or how to obtain GENUINE BEFCO REPLACEMENT PARTS.

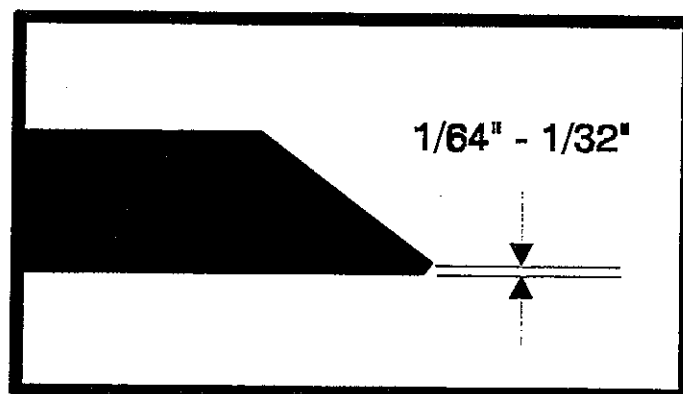
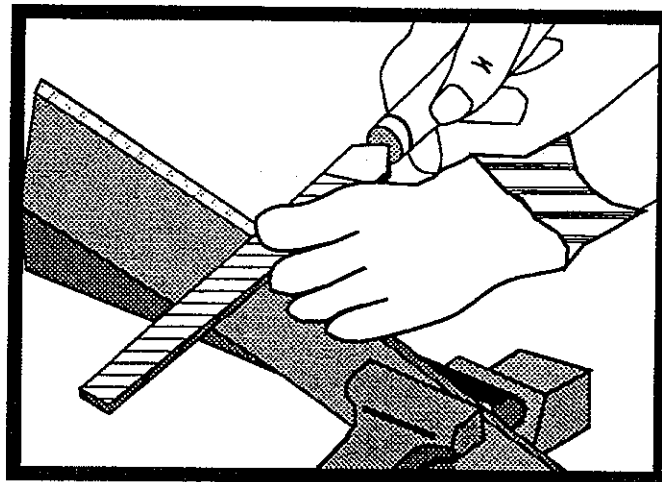

## BELT TENSION

**STEP 1:** Lower hydraulic lift, shut off engine and remove the key.

**STEP 2:** Unscrew the nuts and bolts securing the left and right belt shields and remove the shields.

**STEP 3:** Clean the foreign material from the mower deck and belt area.

**STEP 4:** Check the belt tension by applying a force of 5.4 - 6.8 Kg (12 - 15 lbs) pushing against the belt halfway between the pulleys. The belt deflection should be between 7.9 to 9.5mm (5/16" to 3/8").

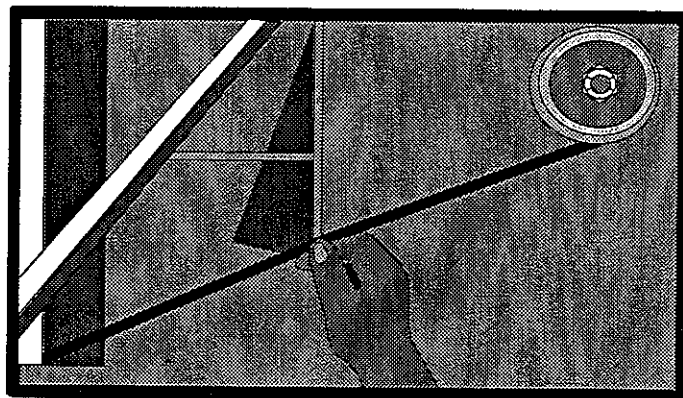

(Continued on next page)

# LUBRICATION AND MAINTENANCE, cont.

If the belts are within the range reinstall the belt shields and tighten the bolts and nuts.

If the belts deflect more than 9.5mm (3/8") tighten the belts. Refer to Replacing Belts section to tighten belts.

## Replacing Belts

- STEP 1:** Lower hydraulic lift, shut off engine and remove the key.
- STEP 2:** Unscrew the 4 nuts and 2 bolts holding the left and right belt shields and remove the shields.
- STEP 3:** Clean the foreign material from the mower deck and belt area.
- STEP 4:** Loosen the four nuts (A) holding the gear box. Then turn the adjustment bolt (B) counter clockwise until the gearbox has slid all the way forward.
- STEP 5:** Remove the old belt if applicable.
- STEP 6:** Place the new belt around the gear-box pulley and middle spindle pulley.
- NOTE:** The belts must be located correctly on the pulleys. The top belt goes in the **top** groove of the middle spindle and gearbox pulleys and in the groove of the outside spindle which measures the **highest** from the deck. The bottom belt is vice versa. (See parts layout on page 21.)
- STEP 7:** Turn the adjustment bolt clockwise until the belt deflection is between 7.9-9.5mm (5/16" x 3/8").
- STEP 8:** Tighten the four nuts holding the gearbox.
- STEP 9:** Reinstall the belt shields and tighten the 2 bolts and 4 nuts.

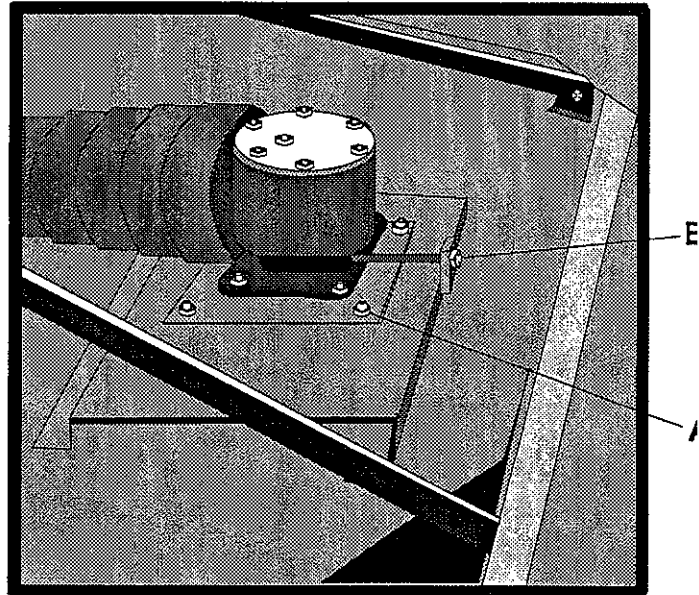

# TROUBLESHOOTING

PROBLEM	POSSIBLE CAUSE	SOLUTION
UNEVEN CUTTING	Washer not between blade and nut	Check washer location at all 3 spindles
	Ground speed too fast	Shift to lower gear
	Blades need sharpening	Sharpen blades
	Caster wheels uneven	Adjust wheel positions
BLADES TURNING BUT NOT CUTTING	Direction of blades is wrong	Blade should turn CCW when you FACE DECK BOTTOM. SEE INSTALLING BLADES SECTION
BELT SLIPPAGE	Lack of tension	Tighten Belt
	Object clogging mower	Remove
	Debris in sheaves	Clean sheaves
MOWER VIBRATES	Object wrapped around blade	Remove object
	Belt damaged	Replace belt
BELT SQUEAL	Belt slipping	Tighten-belt
GRASS BUILD UP AT EXIT	Wet grass	Allow grass to dry
	Grass too high	Raise mower, shift to lower gear, make two passes over grass. Mow grass high 1st pass, 2nd pass cut to desired height.
	Tractor rpm too slow	Increase tractor rpm, check engine and PTO speeds.
BELTS ARE TIGHT WHEN INSTALLING	Wrong belt size	Check belt size
	Installed belts incorrectly	See Replacing Belts section.
STREAKING CONDITIONS IN SWATH	Too wet to mow, blades cannot cut grass pressed down by wheels	Allow grass to dry, maintain engine speed and shift to lower gear.
	Dull blade	Sharpen blade. SEE SHARPENING BLADES SECTION.



Three Spindle Mower  
Frame  
17 - (C24, 25, 26) - 715, RD5, R14

GR 17  
SR 2

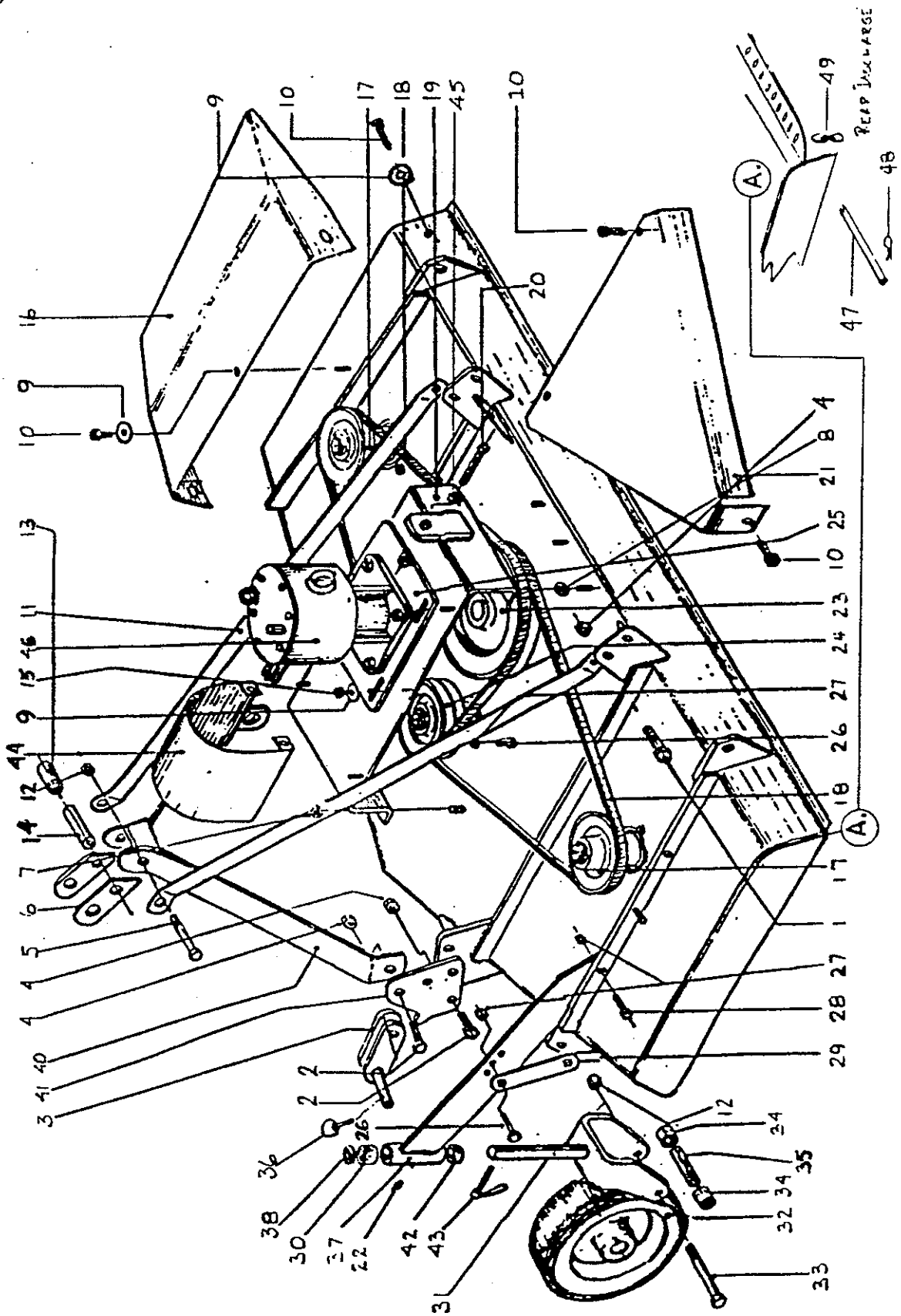



Three Spindle Mower  
Frame  
17 - (C24, 25, 26) - 715, RD5, R14

GR 17  
SR 2

ITEM #	PART #	DESCRIPTION	QTY.
1	000 6578	BOLT M16X45	2
2	003 1038	BOLT M16X50	6
3	000 6573	HITCH BLOCK	2
	501 536B	HITCH BLOCK EXTENSION (Optional)	2
4	000 5581	M16 NUT	8
5	007 0582	BOLT M14X130	1
6	000 6895	TOP HITCH PLATE	2
7	003 0156	NUT M10	18
8	000 1279	NUT M10	4
9	003 0157	FLAT WASHER M10	6
10	003 3176	BOLT M10X25	2
11	000 6837	TOP HITCH ARM C24	2
	000 6838	TOP HITCH ARM C25	2
	000 6839	TOP HITCH ARM C26	2
12	003 0358	M14 NUT	5
13	000 6558	OUTER SPACER	1
14	000 6898	INNER SPACER	1
15	001 4106	M10 LOCK NUT	10
16	000 6781	DEFLECTOR C24	1
	000 6521	DEFLECTOR C25	1
	000 6831	DEFLECTOR C26	1
17	000 6792	120X1 PULLEY C24	2
	000 6622	130X1 PULLEY C25	2
	000 6842	160X1 PULLEY C26	2
18	000 6798	BELT 5V-630 C24	2
	000 6693	BELT 5V-710 C25	2
	000 6848	BELT 5V-850 C26	2
19	000 6904	CENTRAL PLATE C24	1
	000 6875	CENTRAL PLATE C25	1
	000 6913	CENTRAL PLATE C26	1
20	000 6547	BOLT M12X100	1
21	000 6775	BELT PROTECTION C24	2
	000 6515	BELT PROTECTION C25	2
	000 6825	BELT PROTECTION C26	2
22	000 1065	GREASE FITTING	4
23	000 6692	PULLEY SPB 250X2	1
24	000 6791	PULLEY SPB 120X2 C24	1
	000 6621	PULLEY SPB 130X2 C25	1
	000 6841	PULLEY SPB 160X2 C26	1
25	000 6541	GEARBOX FLANGE	1
26	004 6334	BOLT 12X45	4
27	001 3345	LOCK NUT M12	12
28	000 6594	BOLT M12X45	12
29	000 6588	WHEEL REGULATE LEVER	8
30	000 6586	SPACER 1"	4
31	000 6597	WHEEL YOKE	4

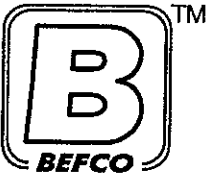

Three Spindle Mower  
Frame  
17 - (C24, 25, 26) - 715, RD5, R14

GR 17  
SR 2

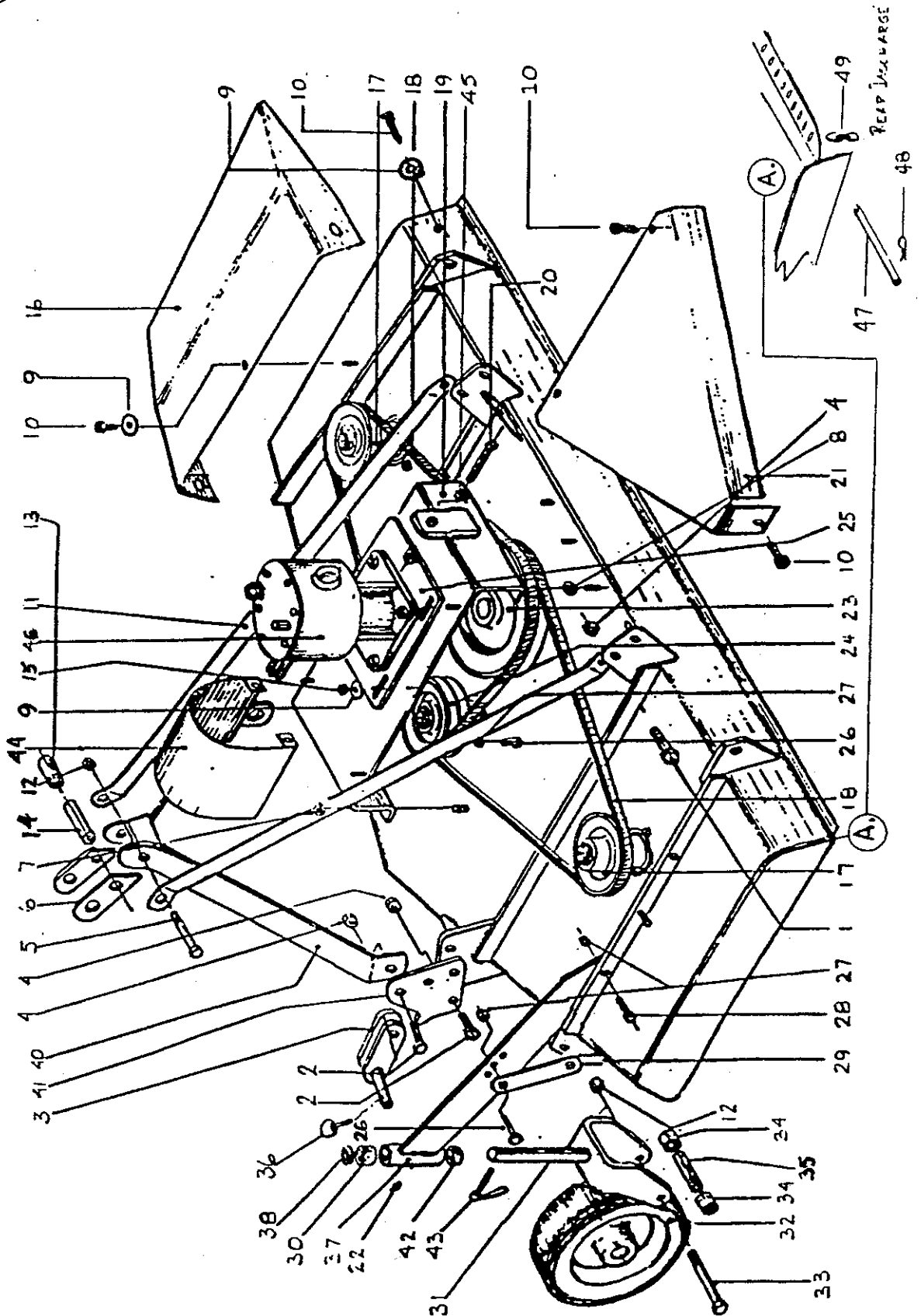



Three Spindle Mower  
Frame  
17 - (C24, 25, 26) - 715, RD5, R14

GR 17  
SR 2

ITEM#	PART #	DESCRIPTION	QTY.
32	000 6611	WHEEL	4
	502 092B	AIR TIRE	-
33	000 6615	BOLT M14X140	4
	502 093B	BUSHING (PNEUMATIC TIRE)	-
34	502 196B	FLAT WASHER M20 (PNEUMATIC TIRE)	8
	000 8842	SPACER	8
35	000 8841	SPACER	4
36	001 8266	LYNCH PIN	2
37	000 6591	WHEEL ARM	4
38	000 6606	SPACER-WASHER	4
39	000 6594	BOLT M12X45	8
40	000 6881	3 POINT HITCH	1
41	000 6540	LOWER HITCH BLOCK PLATE	2
42	000 6587	SPACER 1/2"	4
43	000 8505	LYNCH PIN	4
44	003 4355	PROTECTIVE COVER	1
45	000 1106	NUT M12	2
46	050 0563	GEARBOX COMPLETE	1

FOR REAR DISCHARGE

47	020 6762	ROD 5'	1
	030 6762	ROD 6'	1
48	004 4156	COTTER PIN	1
49	000 6764	CHAIN	-

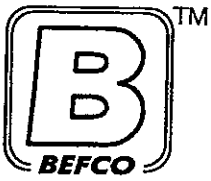

Three Spindle Mower  
Gearbox  
17 - (C24, 25, 26) - 715, RD5, R14

GR 17  
SR 2

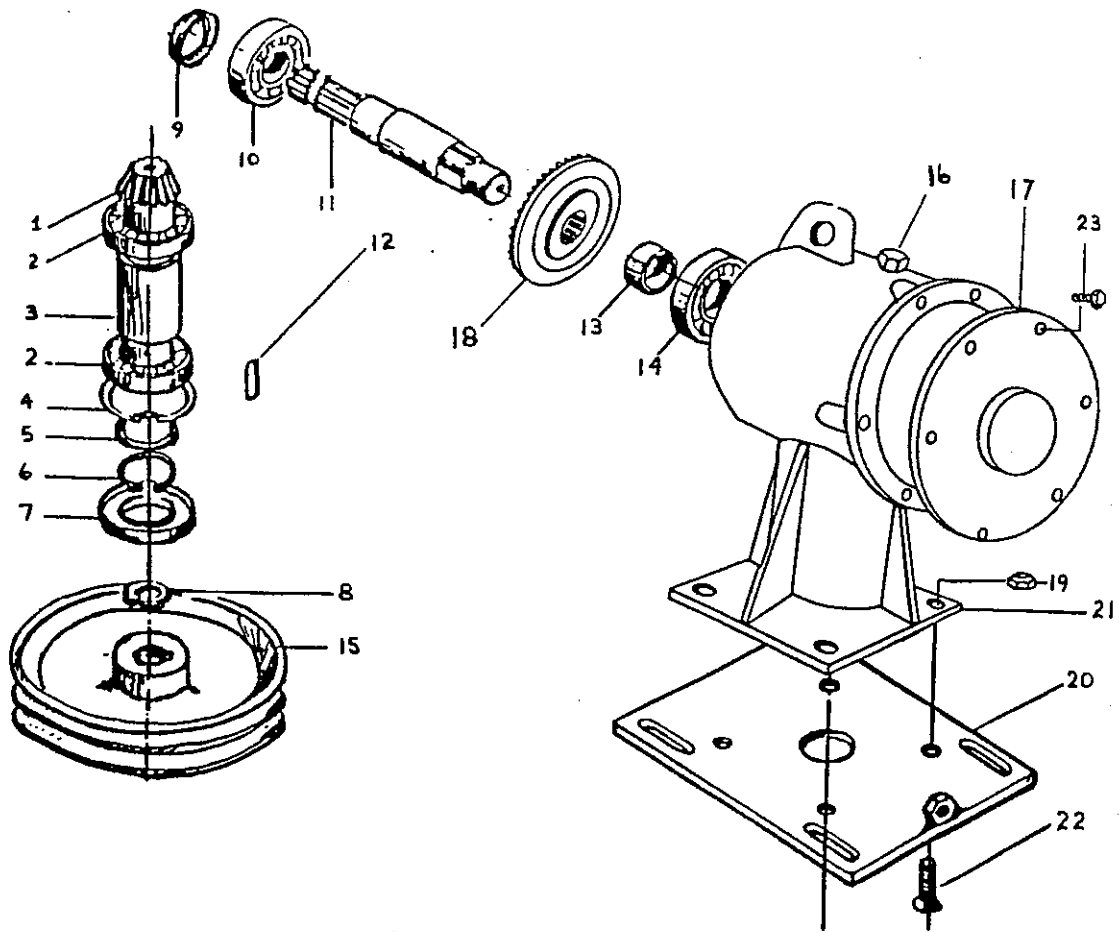





Three Spindle Mower  
Gearbox  
17 - (C24, 25, 26) - 715, RD5, R14

GR 17  
SR 2

ITEM#	PART #	DESCRIPTION	QTY.
1	000 6678	PINION GEAR	1
2	001 2149	BEARING 6208	2
3	000 6687	SPACER	1
4	000 1154	SNAP RING M80 I.	1
5	000 6685	SPACER-WASHER	1
6	000 8138	SNAP RING M40	1
7	000 6684	SEAL, OIL 40.80.10	1
8	000 6698	SAFETY NUT M25	1
9	000 2295	SEAL-OIL 35.62.10	1
10	002 5332	BEARING 6207	1
11	000 6657	SHAFT THROUGH DRIVE	1
12	000 6689	KEY M8X7X35	1
13	000 6667	SPACER	1
14	000 2292	BEARING 6305	1
15	000 6692	PULLEY SPB250X2	1
16	000 5586	DIP STICK	1
17	000 6653	COVER, GEARBOX	1
18	000 6679	RING GEAR	1
19	003 0064	NUT M12	4
20	000 6541	FLANGE, GEARBOX	1
21	000 6652	GEARBOX	1
22	002 0227	BOLT M12X45	4
23	000 1241	BOLT 10X25	6
	050 0563	GEARBOX COMPLETE	-

NOTE: For machines before serial number 141765 use the following numbers:

ITEM#	PART #	DESCRIPTION	QTY
17	000 6675	GEARBOX COVER	1
21	000 6654	GEARBOX HOUSING	1
	050 0534	GEARBOX COMPLETE	-

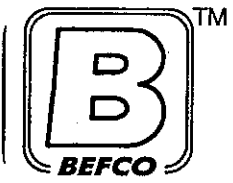

Three Spindle Mower  
Rotor & Blade  
17 - (C24, 25, 26) - 715, RD5, R14

GR 17  
SR 2

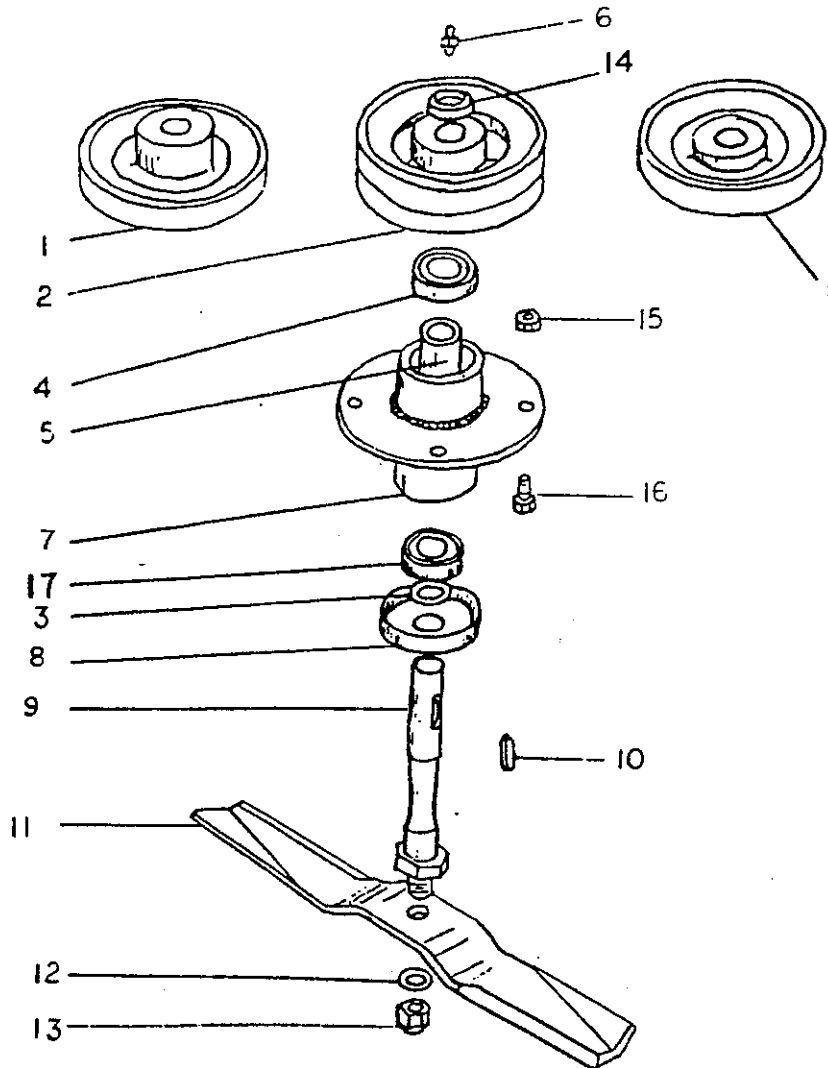

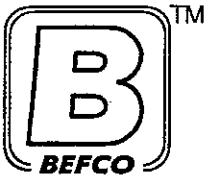

Three Spindle Mower  
Rotor & Blade  
17 - (C24, 25, 26) - 715, RD5, R14

GR 17  
SR 2

ITEM #	PART #	DESCRIPTION	QTY.
1	000 6792	PULLEY SPB 120X1 C24	2
	000 6622	PULLEY SPB 130X1 C25	2
	000 6842	PULLEY SPB 160X1 C26	2
2	000 6791	PULLEY SPB 120X2 C24	1
	000 6621	PULLEY SPB 130X2 C25	1
	000 6841	PULLEY SPB 160X2 C26	1
3	000 6606	SPACER-RING	3
4	000 6634	BEARING 6205Z	3
5	000 6640	SPACER	3
6	002 9036	GREASE FITTING M8	3
7	000 6648	SHAFT SUPPORT	3
8	000 6636	COVER	3
9	000 6638	BLADE HOLDER SHAFT	3
10	000 6639	KEY M8X7X25	3
11	000 6795	BLADE C24	3
	000 6641	BLADE C25	3
	000 6641B	BLADE (HIGHLIFT) C25	3
	000 6641F	BLADE (FLAT) C25	3
	000 6845	BLADE C26	3
	000 6845B	BLADE (HIGHLIFT) C26	3
	000 6845F	BLADE (FLAT) C26	3
12	000 6642	CONICAL SHAPED WASHER	3
13	000 6643	SELF LOCKING NUT M18	3
14	000 6698	SELF LOCKING NUT M25	3
15	003 0156	SELF LOCK NUT M10	12
16	000 1008	BOLT M10X30	12
17	000 6626	BEARING 6205-2Z	3
	000 6620	SPINDLE ASSEMBLY COMPLETE	3

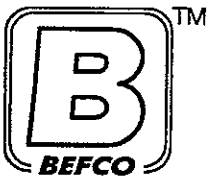

Three Spindle Mower  
PTO  
17 - (C24, 25, 26) - 715, RD5, R14

GR 17  
SR 2

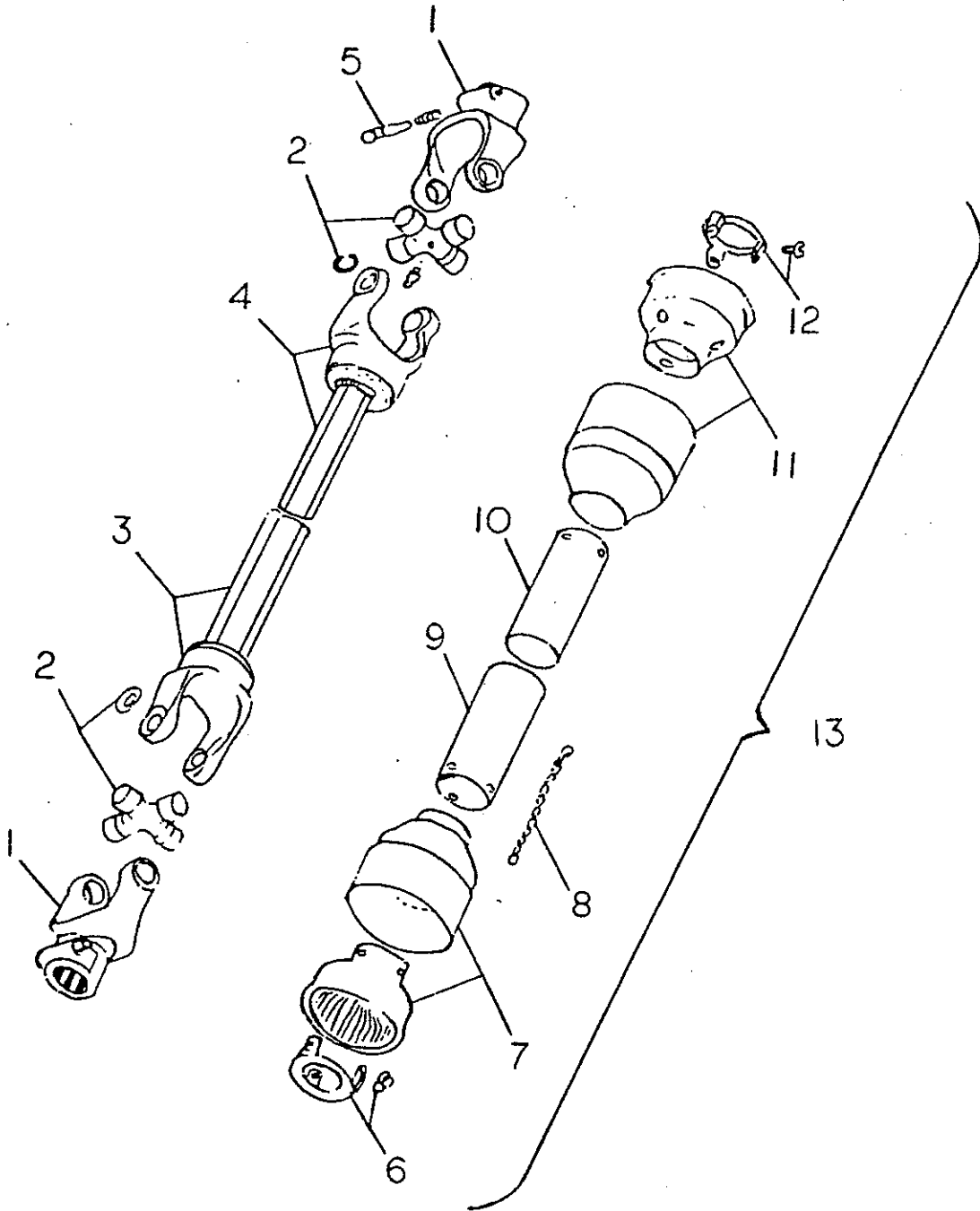

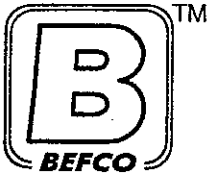

Three Spindle Mower  
PTO  
17 - (C24, 25, 26) - 715, RD5, R14

GR 17  
SR 1

ITEM#	PART #	DESCRIPTION	QTY.
1	023 001E	PUSH PIN YOKE	2
2	013 130E	CROSS & BEARING	2
3	231 018E	OUTER TUBE YOKE C24	1
	231 009E	OUTER TUBE YOKE C25	1
	231 019E	OUTER TUBE YOKE C26	1
4	230 010E	INNER TUBE YOKE C24	1
	230 909E	INNER TUBE YOKE C25	1
	230 011E	INNER TUBE YOKE C26	1
5	026 004E	PUSH PIN SET	2
6	013 012E	LOCKING COLLAR OUTER	1
6A	000 019E	LOCK COLLAR BOLTS - PLASTIC	6
7	013 016E	GUARD CONE OUTER	1
8	016 025E	SAFETY CHAIN	2
9	141 179E	FEMALE SHIELD	1
10	141 275E	MALE SHIELD	1
11	013 028E	GUARD CONE INNER	1
12	013 011E	LOCKING COLLAR INNER	1
13	230 215E	SHIELD COMPLETE	1
	948 204B	PTO COMP. T30 850 MM C24	-
	948 205B	PTO COMP. T30 900MM C25	-
	948 206B	PTO COMP. T30 1050MM C26	-

# ASSEMBLY INSTRUCTIONS

Initial setup, lubrication and adjustment should be performed by the BEFCO dealer. Use the following procedures to properly assemble the mower. Inspect the mower thoroughly after set up and complete the Dealer checklist before delivering the machine to the customer.

This machine is of metric design. The table shown below gives correct torque values for various metric bolts and cap screws. Tighten all bolts to the torques specified.



**CAUTION: MOWER DECK IS HEAVY. USE A SAFE LIFTING DEVICE TO REMOVE MACHINE FROM CRATE.**

This machine is shipped partially assembled in one box. Remove loose parts carefully and layout for easy location. Remove crate sides and leave mower on pallet or remove deck from crate and support on minimum two inch blocks.

NOTE: Right and left hand sides are determined by standing at rear of deck and facing forward.

ALL HARDWARE NEEDED FOR ASSEMBLY WILL BE FOUND IN THE HARDWARE BAG.

NOTE: Assembly will be easier if all mower parts are loosely assembled before tightening the hardware.

## HITCH MOUNT

Locate the 3 point hitch (40) and bolt to deck with the M16x50 bolts (12) and M16 nuts (4).

Locate the inner spacer (14), slide one top hitch plate (6) onto the inner spacer then slide the outer spacer (13) followed by the second top hitch plate (6) onto the inner spacer (14).

Locate the top hitch arms (11). Using the M14x130 bolt (5) and M14 nut (12) bolt the top hitch arm's (11) and top hitch assembly to the 3 point hitch (40).

NOTE: The top hitch plates must move freely. Tighten the bolt for a snug fit but not so as to prevent movement.

TABLE 1: METRIC TORQUE SPECIFICATIONS

BOLT DIAMETER	ASTM CLASS STAMPED ON BOLT HEAD			
	8.8		10.9	
	N.m	(lb-ft)	N.m	(lb-ft)
M8	25	(18)	35	(26)
M10	50	(37)	70	(52)
M12	90	(66)	125	(92)
M14	140	(103)	200	(148)
M16	225	(166)	310	(229)
M18	295	(217)	420	(309)
M20	435	(321)	610	(450)
M25	750	(553)	1050	(774)

When using locks, nuts, increasing torque values by 5%.

# ASSEMBLY INSTRUCTIONS, cont.

Next bolt the top hitch arms by using two bolts (1) and locknuts (4) to the rear of the mower deck.

Locate hitch blocks (3). Attach blocks to deck with 16x50mm hex bolt (2) and locknut (4). Hitch blocks must swing freely. Do not overtighten lock nuts.

**NOTE:** Lifting pins on hitch blocks can be positioned to face inward or outward depending on tractor hitch requirements. Standard position is with pins pointing outward.

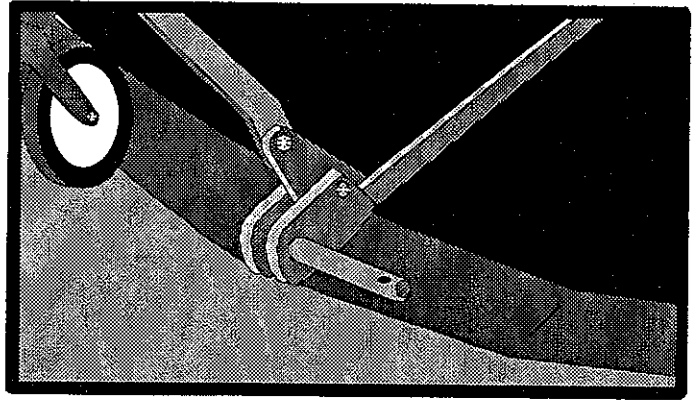

## CASTER WHEEL SUPPORTS

Attach four wheel support arms (37) to deck struts with 12x45mm hex bolt (28) and lock nut (27). Be sure to install arms on inside of face of deck struts.

## CASTER WHEEL ASSEMBLY

Clean and lubricate with a thin coat of grease the yoke pivot shafts (31) and inside bore of tubes on wheel support arms (37). Along with 1/2" & 1" spacers, insert pivot shafts into support arms. Make sure yokes pivot freely. Secure in place with lynch pin (43).

Insert spacers (35) into wheel hub and bushings (34) on both sides, and secure wheels in yokes with 14x140mm hex bolts (33) and lock nuts (12).

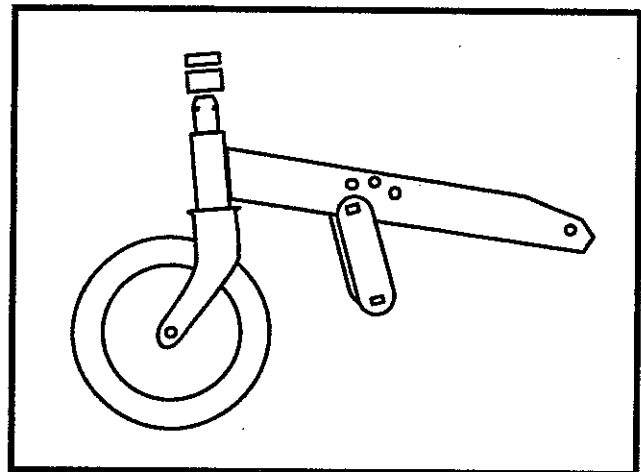

## WHEEL ADJUSTMENT BRACKETS

Attach wheel adjustment brackets (29) to each side of deck lugs with 12x45mm carriage bolts (26) and lock nuts (27). Attach top end of adjustment brackets to adjustment hole in wheel arm with same type carriage bolts and lock nuts. Be sure to use same hole in each arm.

Tighten all wheel support arm and caster wheel hardware. Make sure wheels spin freely in yokes.

# ASSEMBLY INSTRUCTIONS, cont.

## DISCHARGE DEFLECTOR

Position discharge deflector (16) on right side of mower deck as shown and secure with 10x25 hex bolts (10) and flat washer (9). Use large flat washer against slots in deflector.

NOTE: Deflector is adjustable. Outer edge should be adjusted downward to approximately 1.5 inches below top surface of mower deck.

**!** **WARNING: MOWER SHOULD NOT BE OPERATED WITH DISCHARGE DEFLECTOR IN RAISED OR LEVEL POSITION. FAILURE TO ADJUST DEFLECTOR DOWNWARD COULD ALLOW OBJECTS TO BE THROWN BY BLADES FROM MOWER. SERIOUS INJURY OR DEATH COULD RESULT.**

## INSTALL DRIVELINE

Clean and lubricate gear case input shaft splines. Attach female PTO shaft to gear box by pressing spring loaded pin and sliding yoke onto splines until pin snaps into locked position.

Move driveline on shaft to be sure it is locked. Attach chains on PTO shield to mower "A" frame to prevent rotation of shield.

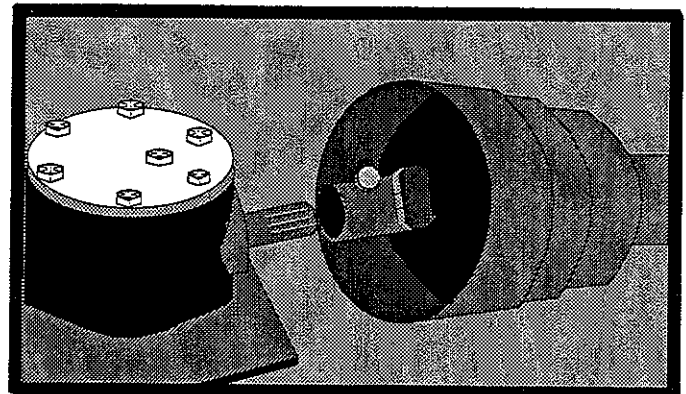
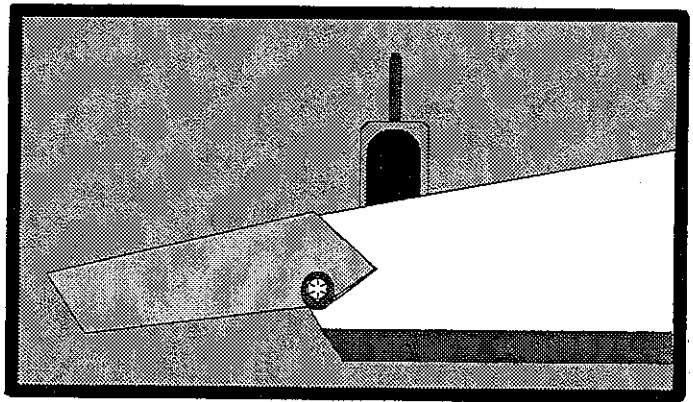



# SPECIFICATIONS

Model	C24	C25	C26
Cutting Width	48"	60"	72"
Length	58"	70"	82"
Width	33"	36"	42"
Height	37"	37"	37"
Weight (lbs.)	430	460	540
Cutting Height Range	1 1/4" to 5 1/3"		
4 Caster Wheels	10 X 3.25 SEMI PNEUMATIC		
Hitch	3 POINT CAT 1		
Driveline	STANDARD 540 RPM 1 3/8' 6-SPLINE		
Recommended PTO HP	15-50	20-50	25-50
PTO Speed	540 RPM		
NO. of Blades	3		
Blade RPM	3170	2926	2378
Blade Tip Speed ft/min	13,714	15,372	15,187
Belt Drive	5V-630	5V-710	5V-850
Gear Pulley Dia. (mm)	250		
Spindle Pulley Dia. (mm)	120	130	160
Gearbox Ratio	1:2.8		

# NOTES

# NOTES

# NOTES

# DELIVERY AND WARRANTY REGISTRATION

BEFCO, Inc.  
 P. O. Box 6036  
 Rocky Mount, NC 27802-6030  
 (919) 977-9920

Date: \_\_\_\_\_

Dealer		Acct. No.	Retail Customer		
Street or Route No.		County	Street or Route No.		
Town	State	Zip	Town	State	County
Date of Delivery		Invoice No.	Zip	Phone	
Model No.		Serial No.			

## PRE-DELIVERY CHECK LIST

- OIL IN GEARBOX
- GREASED FITTINGS
- ALL HARDWARE TIGHT
- PTO LENGTH
- ATTACHED UNIT TO TRACTOR YES/NO
- FIELD ADJUSTED YES/NO
- TEST RUN DRY/INFIELD
- FRICTION CLUTCH
- SHEAR PIN/SIZE \_\_\_\_\_
- HARDNESS \_\_\_\_\_
- INSTRUCTION STICKER
- OPERATOR'S MANUAL

The Machine described above, had been prepared for delivery according to the Pre-Delivery Check List and the Customer has been instructed in its care and operation and the condition of warranty.

Inspected By: \_\_\_\_\_

Date: \_\_\_\_\_

Dealer's signature \_\_\_\_\_

## TRACTOR MAKE:

MODEL \_\_\_\_\_ HP \_\_\_\_\_

Type of Operation: Hobbieist, Landscaper  
 Nursery, Commercial Vegetable, Vineyard,  
 Orchard, Rowcrops, Municipality, Other \_\_\_\_\_

Approx. No. of acres machine will be used on annually \_\_\_\_\_

I hereby acknowledge that:  
 I have received and accepted delivery of the Machine described.

The equipment was checked thoroughly for loose or missing parts and has been adjusted in accordance with the PRE-DELIVERY CHECK LIST.

I have read and understand the nature and extent of the Warranty and understand clearly that there were and are no other representations or warranties, either express or implied, made by anyone. I have been advised on proper operation, maintenance and lubrication procedures of this equipment.

I have been instructed on and do understand the application, limitations and capacities this equipment was designed and recommended for, all as described in the Owner-Operator's manual and literature published by BEFCO.

CUSTOMER SIGNATURE \_\_\_\_\_

DATE: \_\_\_\_\_

FOLD AND STAPLE

AFFIX  
STAMP  
HERE

**BEFCO**  
P. O. Box 6036  
Rocky Mount, NC 27802-6036

Attention: Warranty Department

# WARRANTY

BEFCO's responsibility will be limited to the substitution of the acknowledged defective merchandise to the same place of delivery as the previous one was supplied.

## 1. LIMITED WARRANTY

BEFCO Inc. herein referred to as the Company, warrants its machines and related accessories, hereafter referred to as the Machine, to be free from defects in material and workmanship, for a period of twelve (12) months from the date of invoice to the first registered owner; this limited warranty does not apply to and excludes shear pins, oil, grease, tires, tubes, hydraulic hoses, knives, and PTO shafts.

Labor will be reimbursed at \$17.00 per hour based on BEFCO's timeschedule.

Cost of transport to the servicing dealer is the responsibility of the customer.

Warranty coverage shall not be transferable from the first owner to any subsequent owner.

**2. DISCLAIMER OF ALL OTHER WARRANTIES AND REMEDIES. NEITHER THE COMPANY NOR ANY COMPANY AFFILIATED WITH THE COMPANY MAKES ANY WARRANTIES, REPRESENTATIONS, OR PROMISES, EXPRESSED OR IMPLIED, AS TO THE QUALITY, PERFORMANCE OR APPLICATION OF ITS PRODUCTS OTHER THAN THOSE SET FORTH HEREIN AND DOES NOT MAKE ANY IMPLIED WARRANTY OF MERCHANTABILITY OR FITNESS.**

**THE ONLY REMEDIES THE PURCHASER HAS IN CONNECTION WITH THE BREACH, OR PERFORMANCE OF ANY WARRANTY ON THE COMPANY'S MACHINE ARE THOSE SET FORTH HEREIN. IN NO EVENT WILL THE DEALER, THE COMPANY, OR ANY COMPANY AFFILIATED WITH COMPANY BE LIABLE FOR:**

(a) INJURIES OR DAMAGES OF ANY KIND OR NATURE, DIRECT, CONSEQUENTIAL OR CONTINGENT TO PERSON OR PROPERTY.

(b) ANY EXPENSES INCURRED BY THE OWNER TO REPAIR, REPLACE OR REWORK ANY ALLEGEDLY DEFECTIVE ITEM.

(c) ANY LOSS, COST, FORFEITURE OR DAMAGES (INCLUDING LOSS OF PROFITS; LOSS OF CROPS; LOSS BECAUSE OF DELAY IN FIELD OPERATIONS; ANY EXPENSE OR LOSS INCURRED FOR LABOR, SUPPLIES, SUBSTITUTE MACHINE RENTAL; LIABILITIES OR DAMAGES FOR ANY OTHER REASONS) WHETHER DIRECT OR INDIRECT, AND WHETHER OR NOT RESULTING FROM OR CONTRIBUTED TO BY THE DEFAULT OR NEGLIGENCE OF THE COMPANY, ITS AGENTS, EMPLOYEES AND SUBCONTRACTORS WHICH MIGHT BE CLAIMED AS A RESULT OF THE USE OR FAILURE OF THE EQUIPMENT DELIVERED.

**THE COMPANY'S LIABILITY BASED ON THIS LIMITED WARRANTY OR ANY OTHER APPLICABLE LAWS SHALL BE LIMITED TO REPLACEMENT OR REFUND OF THE PURCHASE PRICE OF THE PRODUCT.**

**THE LIMITED WARRANTY EXTENDED HEREIN GIVES YOU SPECIFIC RIGHTS AND YOU MAY ALSO HAVE OTHER RIGHTS WHICH VARY FROM STATE TO STATE. NEITHER THE DEALER NOR THE COMPANY PERSONNEL HAS THE AUTHORITY TO MAKE ANY REPRESENTATION OR TO MODIFY THE TERMS AND LIMITATIONS OF THIS WARRANTY IN ANY WAY.**

**OTHER THAN THE LIMITED WARRANTY EXTENDED HEREBY. THERE IS NO OTHER EXPRESS WARRANTY IN CONNECTION WITH THE DESIGN, SAFETY OR USE OF ANY OF THE COMPANY'S PRODUCTS EXCEPT AS TO TITLE.**

**ALL IMPLIED WARRANTIES ARE EXPRESSLY DISCLAIMED PURSUANT TO THE TERMS OF THE WARRANTY.**

## 3. CUSTOM WORK

If the machine is used for commercial purposes such as custom work the period warranted for the Machine is limited to six (6) months from the date of delivery to the first registered owner and does not cover any labor charges incurred.

## 4. RENTAL

If the Machine is used for rental purposes the period warranted for the Machine is limited to thirty (30) days from the date of delivery to the first registered owner and does not cover any labor charges incurred.

## 5. REGISTRATION

In order to qualify for coverage on this limited warranty, the product and name of the original purchaser must be registered with the Company by mailing a completed Machine Delivery and Warranty Registration along with a copy of the dealer's invoice to the first registered owner to the Company within fourteen (14) days after the date of delivery to the original purchaser.

## 6. WARRANTY SERVICE

Warranty Service must be performed by a dealer authorized by BEFCO. If the warranty service requested is approved, the owner shall pay only for labor beyond the rate allowed, for overtime labor, and for any mileage charge for transporting the equipment to and from the dealer's shop. It is assumed that the dealer has the appropriate general and special tools to service the machine. Time required for replacement of knives, oil, grease and to remove excessive dirt from the Machine is not subject to reimbursement by the Company. The owner is required to clean the Machine before presenting it to the dealer for service work. The machine must be delivered within thirty (30) days after failure date by the owner to the dealer to be eligible for warranty consideration.

## 7. UNAPPROVED SERVICE OR MODIFICATION

All obligations of the Company under this limited warranty shall be terminated if:

(a) Proper Service and Operation Instructions as outlined the Owner's manual and on the instruction sticker on the Machine, are not followed.

(b) The Machine is modified or altered in any way not approved by the Company.

(c) The Company does not receive a copy of the dealers invoice to the first registered owner within fourteen (14) days from the date of delivery.

(d) The Company has not been paid in full, by the dealer, for the machine.

## 8. ACCIDENTS AND NORMAL MAINTENANCE

This limited warranty covers defective material and workmanship. It does not cover depreciation or damage caused by normal wear, accidents, improper maintenance, improper protection or improper use. The costs of normal maintenance or repairs for accidents or improper use, and related labor will be borne by the owner.

---

**BEFCO**

P.O. Box 6036

Rocky Mount, NC 27802-6036

Tel.: 252.9779920 - Fax: 252.9779718

[www.befco.com](http://www.befco.com)

