

# **BEFCO®**

## **Parts Manual**

### **CYCLONE SERIES 3**

**Three Spindle Grooming Mower**

**090-711, 110-711**

**090-712, 110-712**

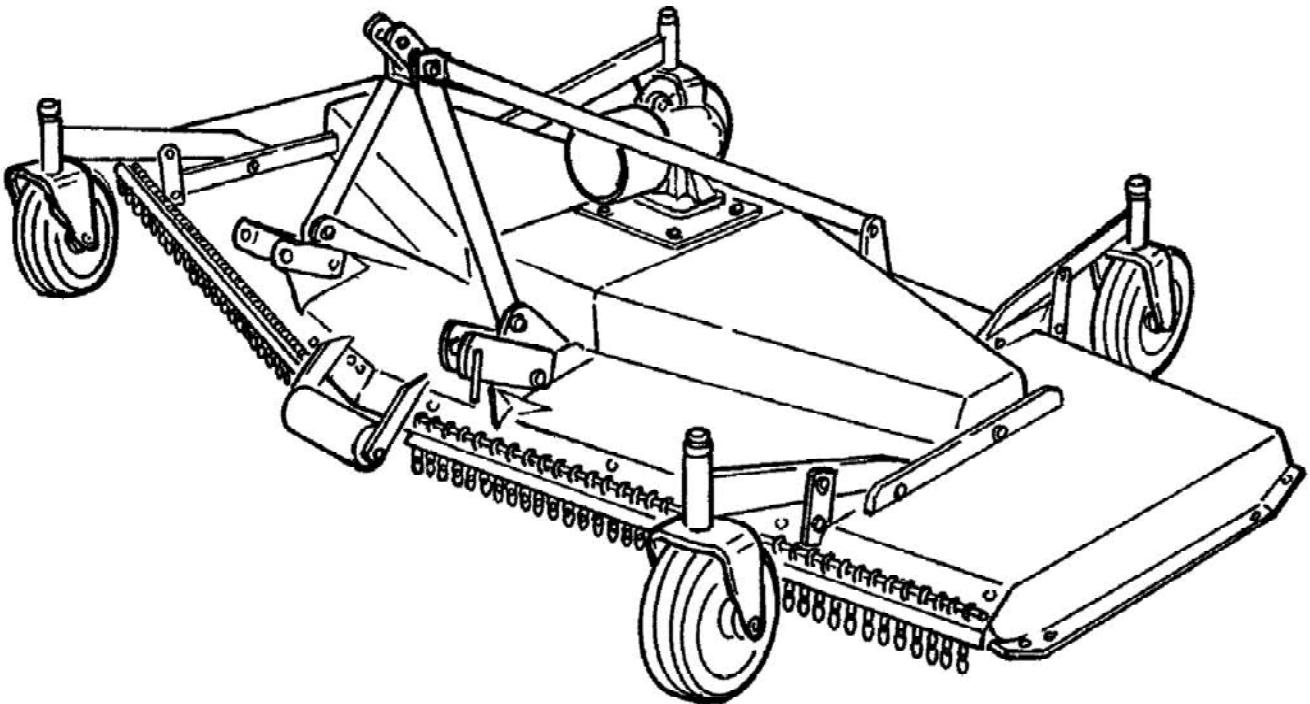

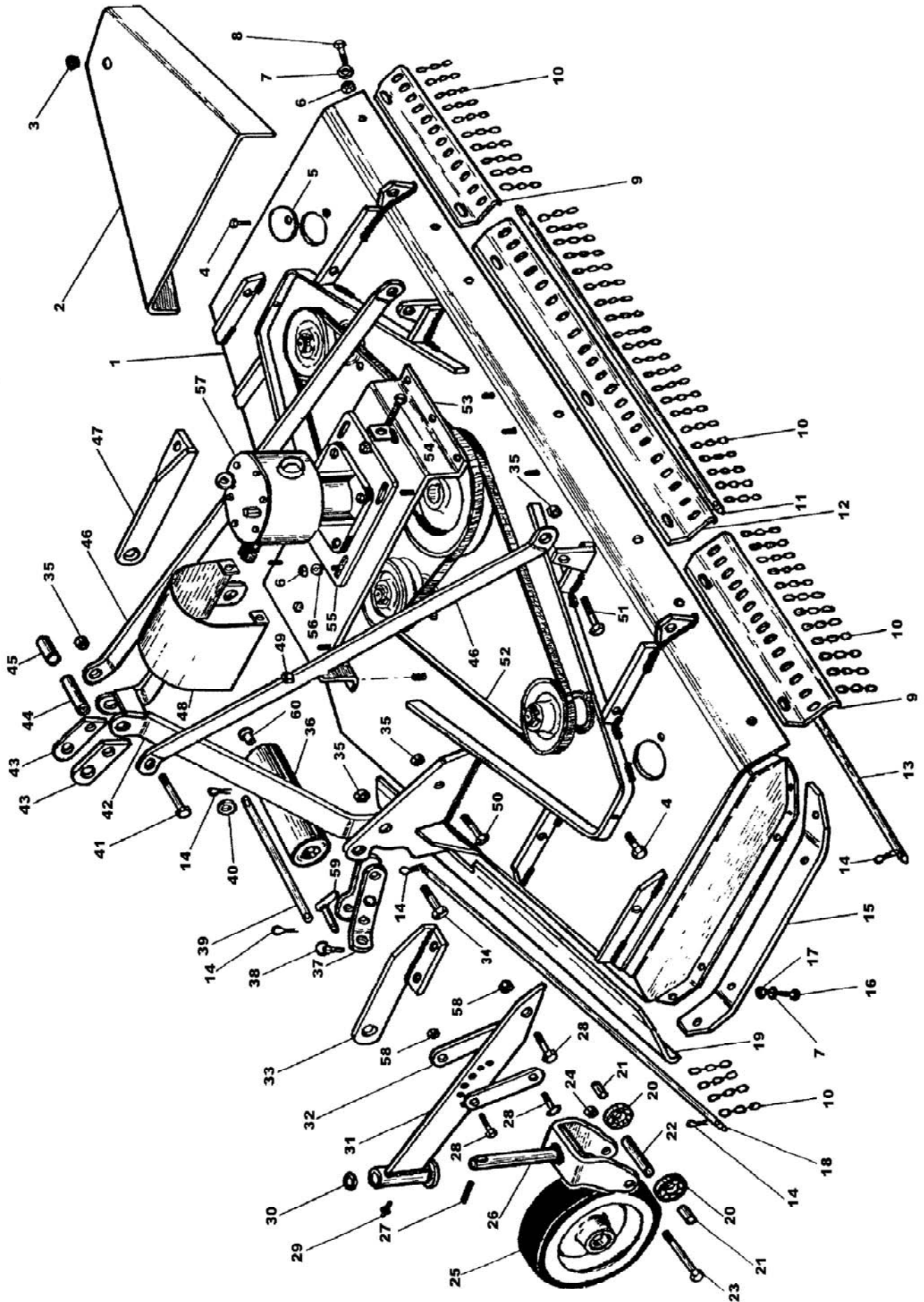

Ref.	Part #	Description	Qty.
1	004-4002	Frame 090	1
	004-4502	Frame 110	1
2	004-4161	Belt protection 090	2
	004-4571	Belt protection 110	2
3	000-6647	Plastic cap	3
4	000-3037	Bolt HH M12-1.75x25 C8.8 Z F	9
5	004-4091	Cover	3
6	001-3345	Nut ES M12-1.75 Z TK	-
7	000-2265	Washer, flat Ø12 Z	-
8	004-4146	Bolt CR M12-1.75x25 C8.8 Z	-
9	004-4144	Side protection, rear 090	2
	004-4554	Side protection, rear 110	2
10	004-4158	Chain	-
11	004-4152	Rear pivot 090	1
	004-4563	Rear pivot 110	1
12	004-4143	Central protection, rear 090	1
	004-4553	Central protection, rear 110	1
13	004-4153	Rear pivot left 090	1
	004-4562	Rear pivot left 110	1
14	004-4156	Cotter pin Ø4x25	6
15	004-4021	Side skid 090	2
	004-4531	Side skid 110	2
16	004-4023	Bolt CS M12-1.75x30 C10.9 Z F	8
17	000-1106	Nut HH M12-1.75 C6 Z MD	8
18	004-4151	Front pivot 090	2
	004-4561	Front pivot 110	2
19	004-4141	Front protection 090	2
	004-4551	Front protection 110	2
20	000-6634A	Bearing, hard tire 6205-Z	8
	502-406B	Bearing, air tire	8
	502-407B	Retainer, air tire	8
21	004-4133	Wheel spacer	8
22	004-4138	Wheel spacer, hard tire	4
	502-121B	Wheel spacer, air tire	4
23	004-4135	Bolt HH M14-2.00x170 C8.8 Z P, hard tire	4
	502-122B	Bolt, air tire	4
24	003-0358	Nut PT M14-2.00 C6 Z TK, hard tire	4
	502-123B	Nut, air tire	4
25	004-4131	Hard tire	4
	502-120B	Air tire	4
26	004-4121	Wheel yoke, hard tire (short shaft); 090-711 & 110-711	4
	004-4125	Wheel yoke, hard tire (long shaft); 090-712 & 110-712	4
	004-4129	Spacer 1", for wheel yoke with long shaft; 090-712 & 110-712	4
	004-4130	Spacer ½", for wheel yoke with long shaft; 090-712 & 110-712	4
	004-4117	Wheel yoke, air tire	4
27	000-5521	Roll pin Ø10x45	4
	502-542B	Lynch pin	4
28	000-6594	Bolt CR M12-1.75x45 C8.8 Z	8
	004-4112	Bolt CR M12-1.75x55 C8.8 Z	4
29	000-1065	Grease fitting M10-1.00	4
30	004-4128	Spacer washer	4

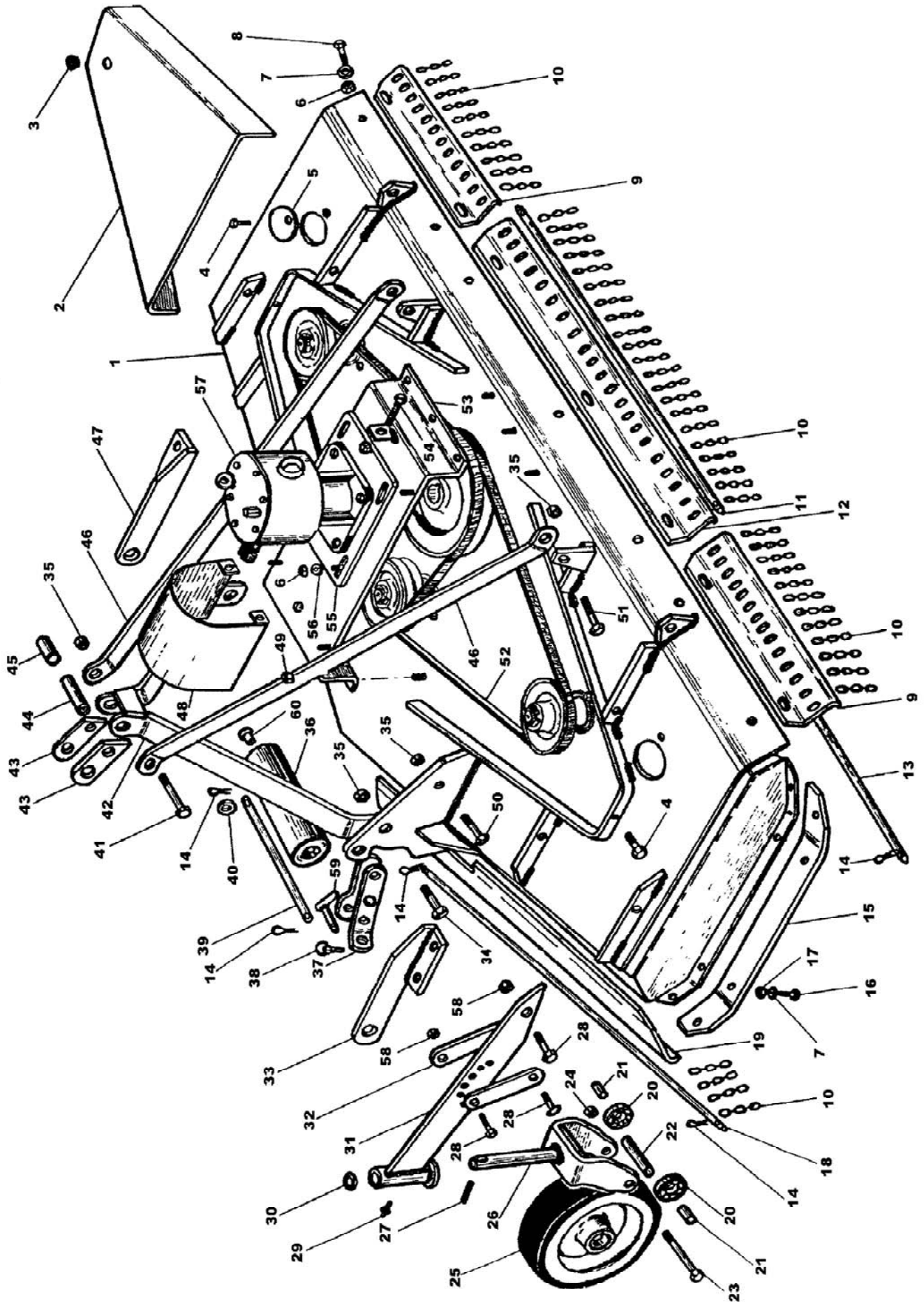

Ref.	Part #	Description	Qty.
31	004-4101	Wheel arm (6 holes), for short shaft wheel yoke; 090-711 & 110-711 <sup>1</sup>	4
	004-4107	Wheel arm (3 holes), for long shaft wheel yoke; 090-712 & 110-712	4
32	004-4111	Wheel regulate lever	8
33	024-4031	Roller support left; #146999 & below	1
	044-4031	Roller support left; #147000 & above	1
34	003-3218	Bolt HH M16-2.00x55 C8.8 Z P	2
35	000-5581	Nut PT M16-2.00 C6 Z TK	7
36	004-4038	Front roller	1
37	004-4073	Hitch block	2
	501-743B	Hitch block, extended plate (option)	2
38	001-8266	Lynch pin	2
39	004-4039	Roller pin	1
40	000-8568	Washer, flat Ø16	1
41	000-6891	Bolt HH M16-2.00x140 C8.8 Z P	1
42	004-4061	Three point hitch	1
43	004-4069	Upper plate	2
44	004-4067	Inner spacer	1
45	000-6558	Outer spacer	1
46	004-4081	Top hitch arm 090	2
	004-4545	Top hitch arm 110	2
47	014-4031	Roller support right; #146999 & below	1
	034-4031	Roller support right; #147000 & above	1
48	000-8663	Shaft protection	1
49	003-0064	Nut PT M12-1.75 C6 Z TK	6
50	000-6578	Bolt HH M16-2.00x45 C8.8 Z F	2
51	003-2687	Bolt HH M16-2.00x40 C8.8 Z F	2
52	004-4253	Belt CX 98 (090-711, 090-712)	2
	004-4595	Belt CX 110 (110-711, 110-712)	2
53	004-4171	Central plate 090	1
	004-4581	Central plate 110	1
54	000-6547	Bolt HH M12-1.75x100 C8.8 Z F	1
55	004-4187	Gearbox support plate	1
56	007-6106	Washer, flat Ø12	4
57	050-0608	Gearbox complete	1
58	009-4139	Nut ES M12-1.75 Z TN	8
59	004-4078	Hitch pin	2
60	004-4040	Bushing	2

<sup>1</sup> Part no longer available, substitute with part #004-4107, drilling required to add 3 holes and obtain all cutting height adjustments.

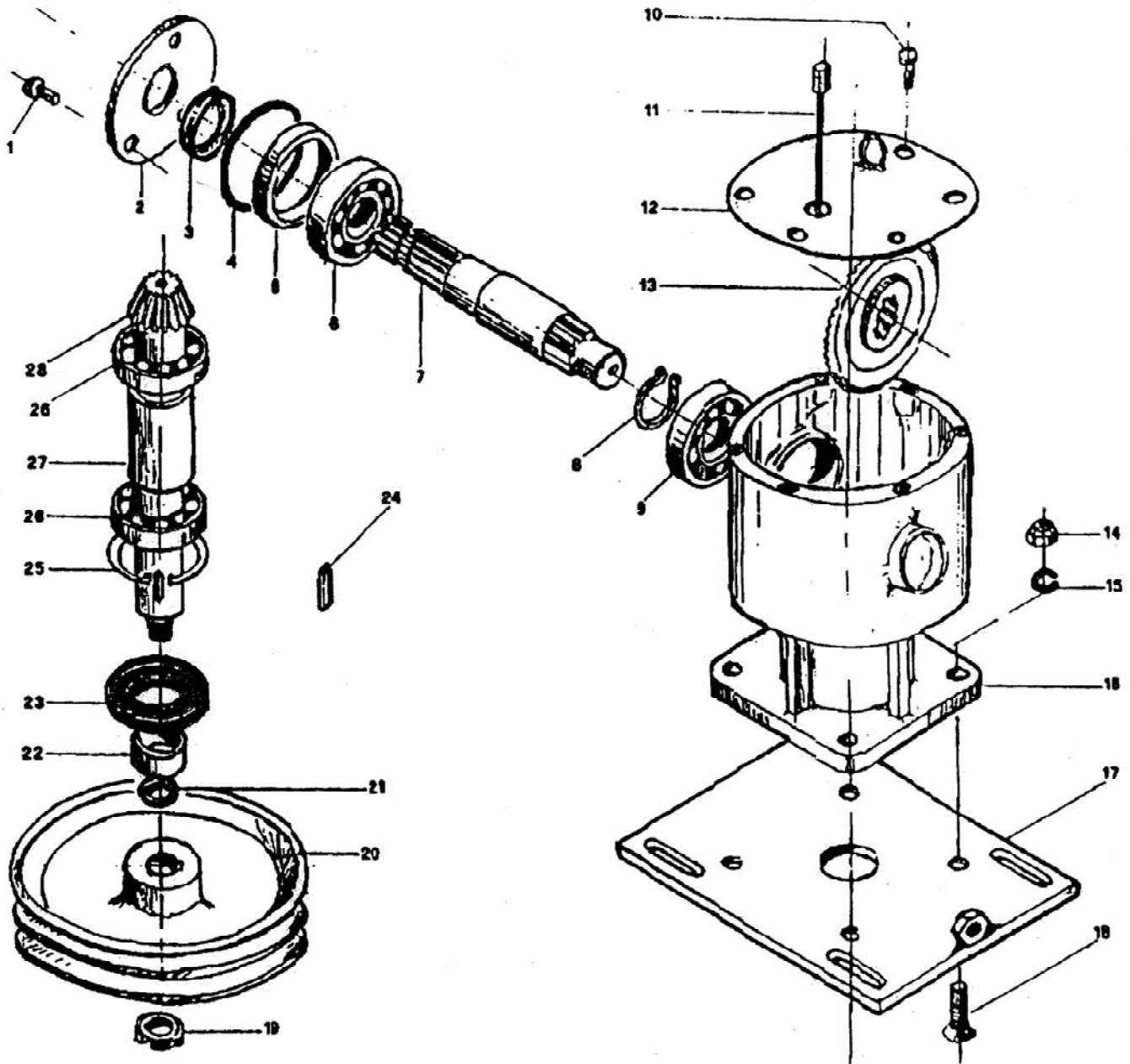

Ref.	Part #	Description	Qty.
1	000-1046	Bolt HH M10-1.50x20 C8.8 N F	3
2	000-5567	Cover, front	1
3	000-2295	Oil seal 35.62.10	1
4	000-7181	Gasket OR 740	1
5	004-4213	Spacer, front	1
6	000-7172	Bearing 30207	1
7	000-5556	Input shaft	1
8	004-2122	Snap ring, outer Ø35	1
9	004-4217	Bearing 30305	1
10	000-5588	Bolt HH M10-1.50x16 C8.8 N F	6
11	000-5586	Dipstick for gearbox #050-0542	1
12	000-6675	Gearbox cover BRE 339 <sup>2</sup> ; serial #143148 & below	1
13	004-4221	Ring gear	1
14	000-1106	Nut HH M12-1.75 C6 Z MD	4
15	000-1077	Washer, lock Ø12 Z	4
16	000-6654	Gearbox housing BRE 339; serial #143148 & below	1
17	004-4187	Gearbox plate support	1
18	002-0227	Bolt CS M12-1.75x45 C10.9 Z F	4
19	003-0095	Locking ring ES GUK M30-1.50	1
20	004-4251	Pulley C/280x2 (090)	1
	004-4593	Pulley C/250x2 (110)	1
21	000-5969	Gasket OR 3156	1
22	004-4245	Spacer	1
23	000-1155	Oil seal 50.80.10	1
24	004-4244	Key 8x7x40	1
25	000-1154	Snap ring, inner Ø80	1
26	001-2149	Bearing 6208	2
27	000-6687	Spacer	1
28	004-4222	Pinion gear	1
	050-0542	Gearbox complete; #143148 & below <sup>3</sup>	-

<sup>2</sup> Substitutes part #004-4225.

<sup>3</sup> Complete gearbox interchangeable with part #050-0614.

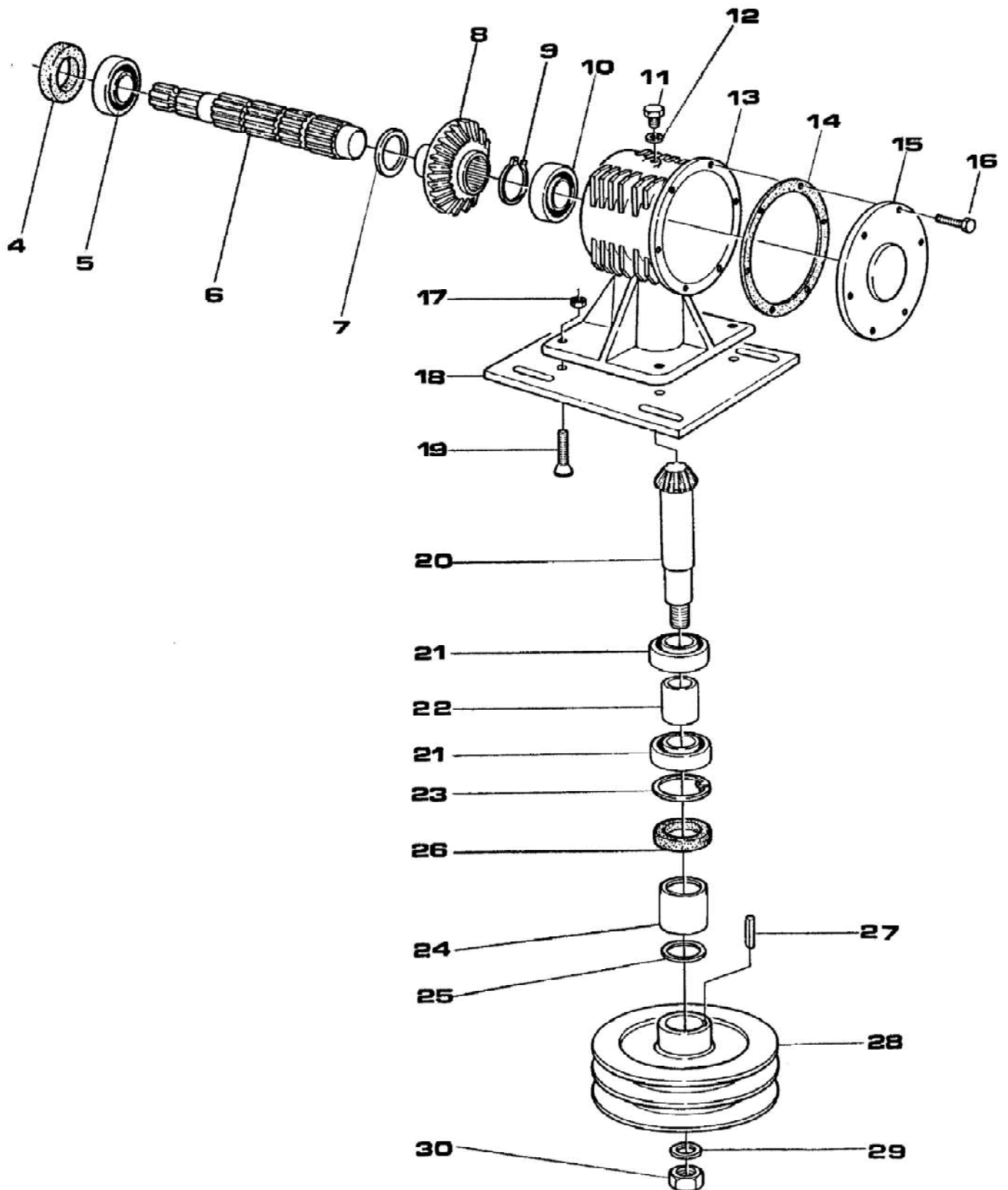



## 090-712, 110-712 SERIAL #143149 &amp; ABOVE

Ref.	Part #	Description	Qty.
4	000-2295	Oil seal 35.62.10	1
5	000-7172	Bearing 30207	1
6	000-5556	Input shaft	1
7	004-4223	Spacer washer	1
8	004-4221	Ring gear	1
9	004-2122	Snap ring, outer Ø35	1
10	004-4217	Bearing 30305	1
11	000-5586	Dipstick for gearbox #050-0565	1
	000-1107A	Breather cap for gearbox #050-0608	1
12	000-6691	Gasket	1
13	000-6652	Gearbox housing without fins BRE 354	1
	000-6658	Gearbox housing with fins ROTO 102	1
14	003-0193	Gasket (0.012)	-
	013-0193	Gasket (0.028)	-
15	000-6653	Gearbox cover for gearbox without fins BRE 354	1
	000-6656	Gearbox cover for gearbox with fins ROTO 102	1
16	000-1046	Bolt HH M10-1.50x20 C8.8 N F	6
17	003-0064	Nut PT M12-1.75 C6 Z TK	4
18	004-4187	Gearbox support plate	1
19	000-2078	Bolt CS M12-1.75x40 C8.8 Z F	4
20	004-4222	Pinion gear	1
21	001-2149	Bearing 6208	2
22	000-6687	Spacer	1
23	000-1154	Snap ring, inner Ø80	1
24	004-4245	Spacer	1
25	000-5969	Gasket OR 3156	1
26	000-1155	Oil seal 50.80.10	1
27	004-4244	Key 8x7x40	1
28	004-4251	Pulley C/280x2 (090-712)	1
	004-4593	Pulley C/250x2 (110-712)	1
29	006-6039	Washer, flat Ø31	1
30	003-0095	Locking ring ES GUK M30-1.50	1
	050-0565	Gearbox complete without fins <sup>4</sup>	-
	050-0608	Gearbox complete with fins <sup>5</sup>	-

<sup>4</sup> Complete gearbox interchangeable with part #050-0614.

<sup>5</sup> Complete gearbox interchangeable with part #050-0614.

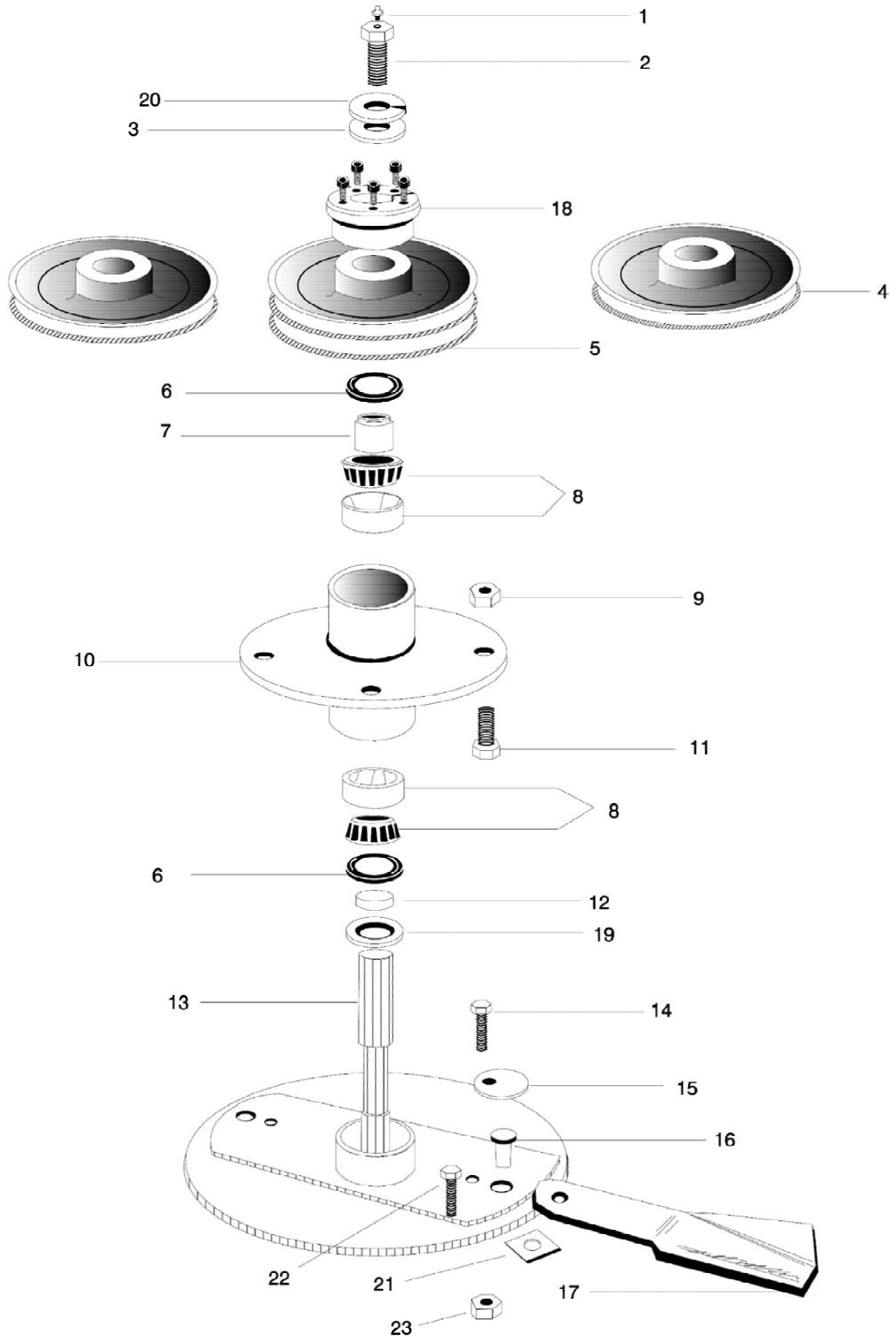

Ref.	Part #	Description	Qty.
1	000-6635	Grease fitting Ø6, press in	3
2	004-4274	Banjo bolt M14x25	3
3	004-4275	Washer, flat Ø14x42x3	6
4	004-4266	Pulley C/200x1	2
5	004-4265	Pulley C/200x2	1
6	000-1059	Oil seal 45.65.10	6
7	004-4277	Spacer	3
8	004-4281	Bearing 32007	6
9	003-0064	Nut PT M12-1.75 C6 Z TK	12
10	004-4285	Rotor support	3
11	004-6333	Bolt HH M12-1.75x45 C8.8 N F	12
12	004-4283	Spacer	3
13	004-4301	Rotor blade holder	3
14	000-3037	Bolt HH M12-1.75x25 C8.8 Z F	6
15	003-0067	Washer with holes	6
16	004-4315	Pin	6
17	004-4318	Blade 090	6
	004-4598	Blade 110	6
18	005-0117	Split lock bushing	3
19	006-6039	Washer, flat Ø31x63x5	3
20	000-1020	Washer, lock Ø14 Z	3
21	004-4317	Blade stop plate	6
22	000-7255	Bolt HH M12-1.75x35 C8.8 Z F	6
23	003-0064	Nut PT M12-1.75 C6 Z TK	6
	004-4290	Spindle, complete	3

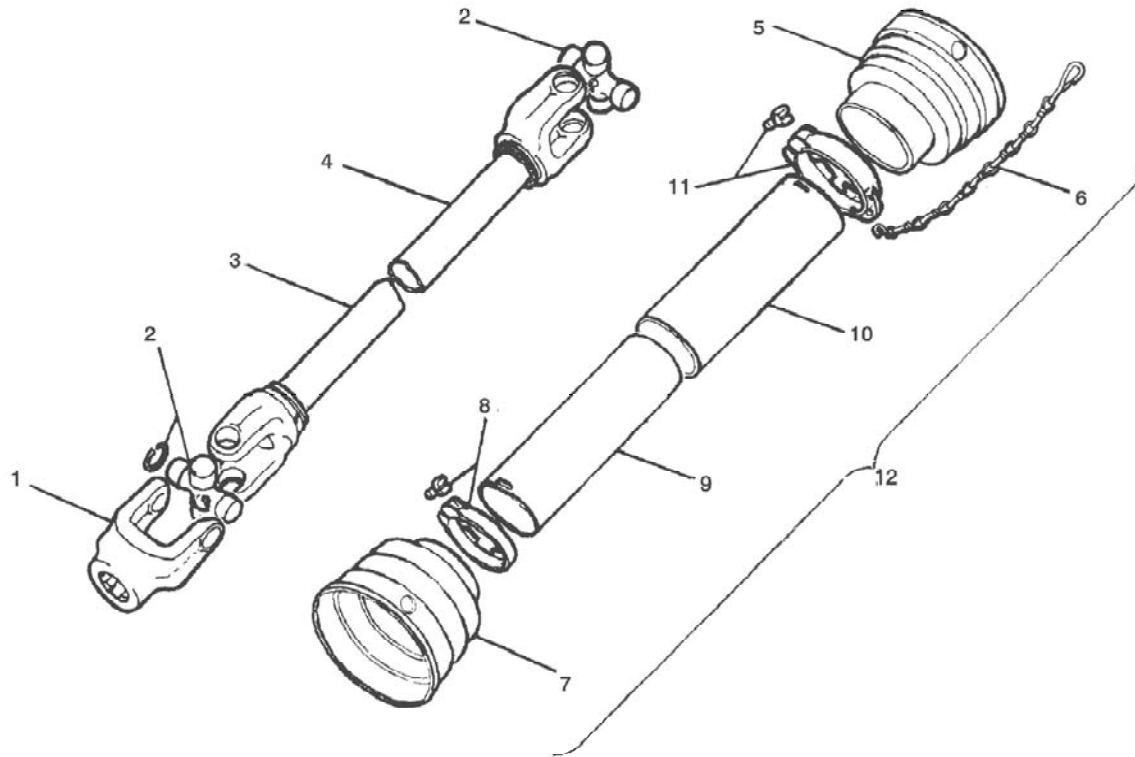

Ref.	Part #	Description	Qty.
1	024-001E	PTO yoke <sup>6</sup>	2
2	014-130E	Cross & bearing <sup>7</sup>	2
3	240-931E	Inner tube & yoke 1050	1
4	241-035E	Outer tube & yoke 1050	1
5	013-016E	Guard cone, outer	1
6	016-025E	Safety chain <sup>8</sup>	1
7	013-028E	Guard cone, inner	1
8	013-011E	Locking collar, inner	1
9	141-275E	Shield, inner	1
10	141-179E	Shield, outer	1
11	013-012E	Locking collar, outer	1
12	240-255E	Shield complete	1
	948-137B	Driveline complete <sup>9</sup>	-

<sup>6</sup> Yoke interchangeable with part #1024010C.  
<sup>7</sup> Cross & bearing interchangeable with part #1004020C.  
<sup>8</sup> Safety chain interchangeable with part #1006065C.  
<sup>9</sup> Complete driveline interchangeable with part #050-0416.

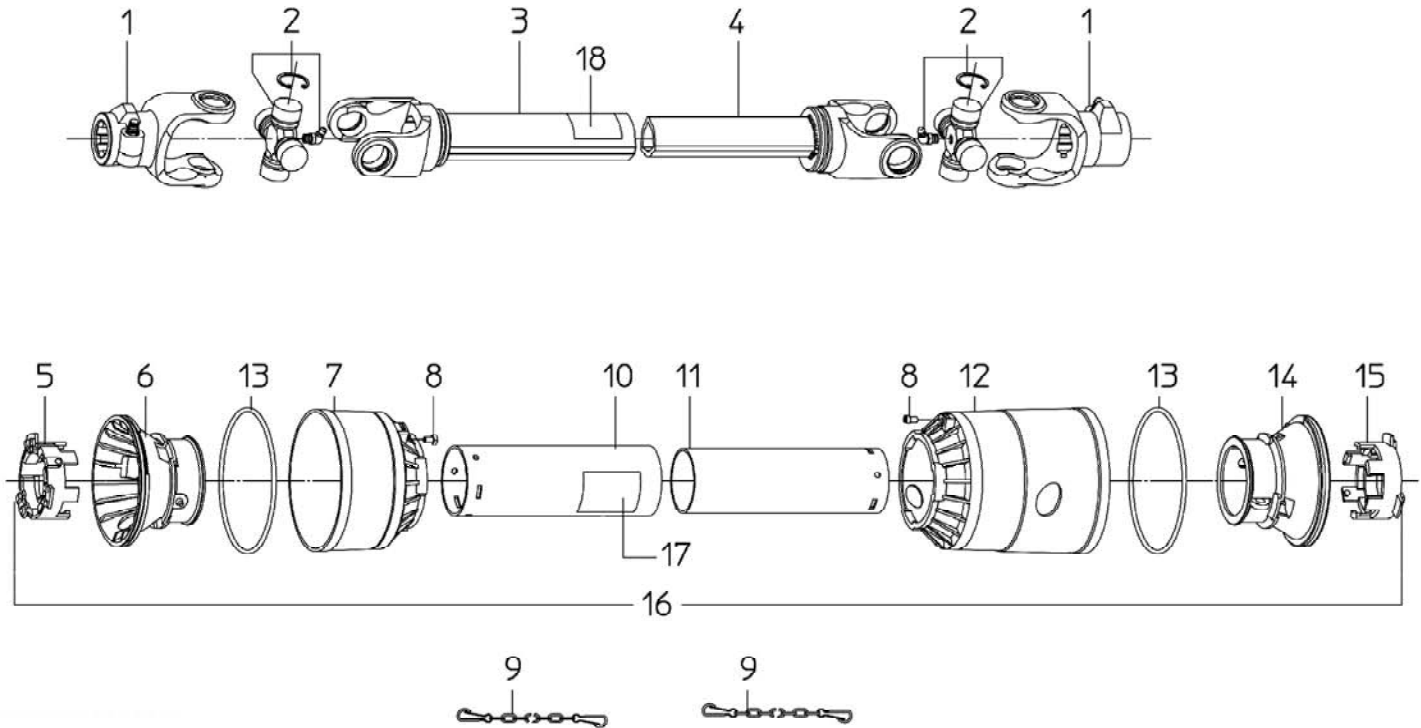

Ref.	Part #	Description	Qty.
1	1024010C	PTO yoke	2
2	1004020C	Cross & bearing	2
3	1944070NC	Outer tube & yoke	1
4	1954072NC	Inner tube & yoke	1
5	1784210C	Locking ring, outer tube	1
6	1784201C	Rigid cone, outer tube	1
7	1784203C	Standard cone (tractor end)	1
8	1784212C	Pin	2
9	1006065C	Chain	2
10	1773068C	Shield, outer tube	1
11	1872068C	Shield, inner tube	1
12	1784205C	Long cone (implement end)	1
13	1213233C	Stiffening ring	2
14	1784202C	Rigid cone, inner tube	1
15	1784211C	Locking ring, inner tube	1
16	90SL4068C	Complete shielding <sup>10</sup>	1
17	950-463B	Decal "DANGER - Rotating driveline, keep away" outer shield	1
18	950-464B	Decal "DANGER - Guard missing, do not operate" outer tube	1
	050-0416	Driveline complete	-

<sup>10</sup> Complete shielding interchangeable with part # 96SL4068C.



## **Use only original spare parts**

*All rights reserved. It is unlawful to copy, reprint or use any of the information or details in this manual without the expressed written permission of the Company. Technical information provided in this manual is approximate, the Company reserves the right to modify or improve the models shown for technical or commercial purposes. Pictures in this manual do not necessarily show the machine as delivered.*

---

**BEFCO**<sup>®</sup>

P.O. Box 6036  
Rocky Mount, NC 27802-6036  
Tel.: 252.977.9920 - Fax: 252.977.9718  
[www.befco.com](http://www.befco.com)

