

BEFCO®

Parts Manual

CYCLONE FLEX

**Tri-wing Grooming Mower
212, 215, 217-706**

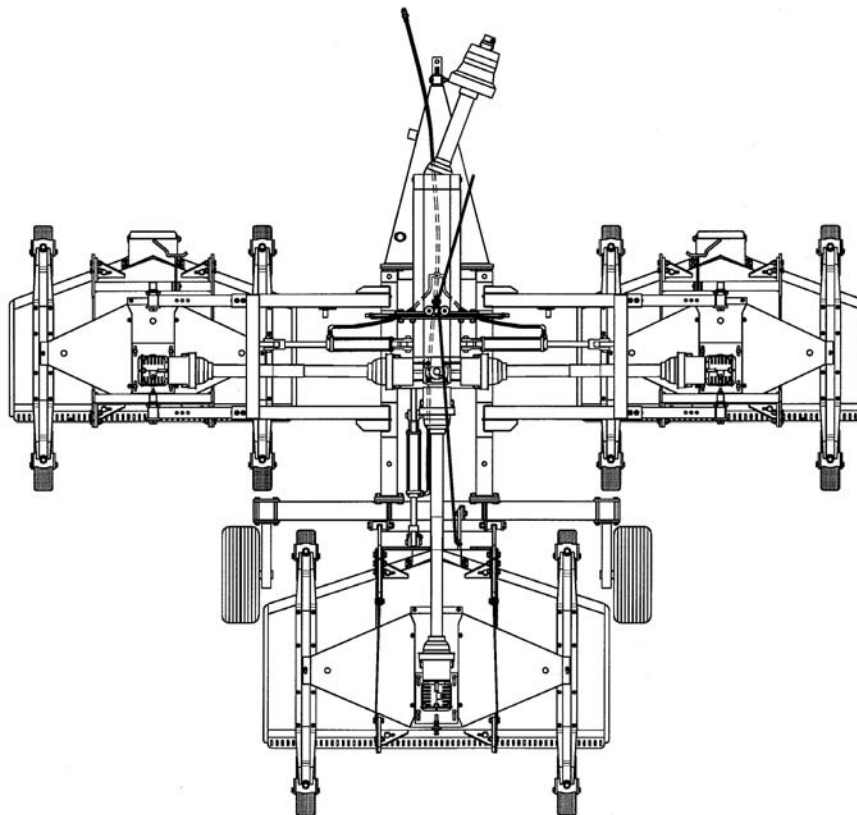

**Manual 971-159B
July 2000**

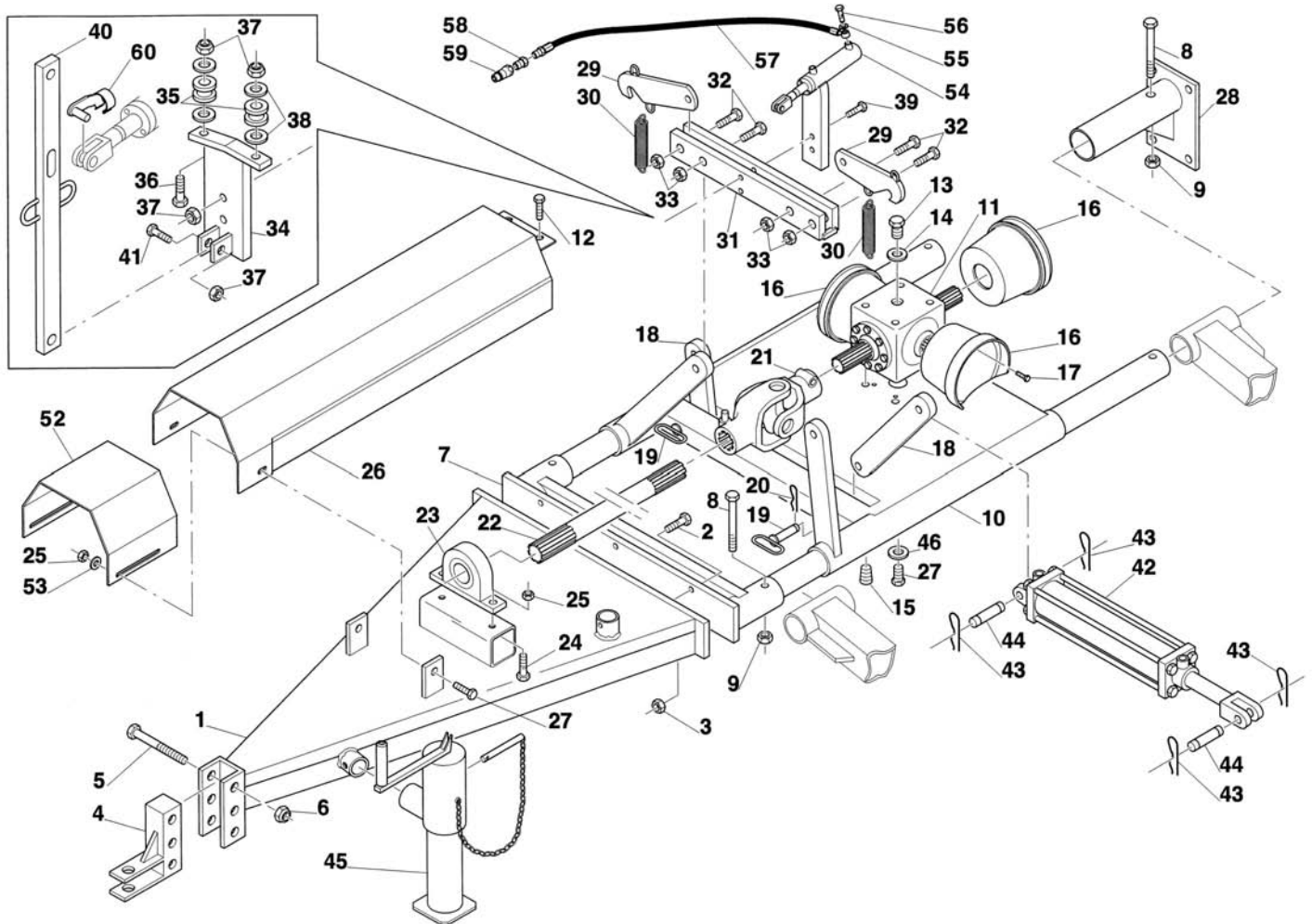

Ref.	Part #	Description	Qty.
1	000-9601	Drawbar; 212, 215, 217-706	1
2	006-4377	Bolt HH M18-2.50x45 C8.8 Z F	6
3	001-7506	Nut PT M18-2.50 C6 Z TK	6
4	000-9013	Front hitch	1
5	000-5536	Bolt HH M14-2.00x90 C8.8 Z P	2
6	003-0358	Nut PT M14-2.00 C6 Z TK	2
7	000-9612	Central frame hitch; 212, 215, 217-706	1
8	000-6480	Bolt HH M14-2.00x100 C8.8 N P	4
9	000-1103	Nut HH M14-2.00 C6 N MD	4
10	000-9641	Main frame; 212, 215, 217-706	1
11	050-0617	Gearbox, complete	1
12	006-4648	Bolt HH M12-1.75x20 C8.8 Z F	6
13	000-1107A	Breather cap	1
14	000-6691	Gasket	2
15	005-3446	Cap	1
16	000-8663	Shaft protection	3
17	000-6349	Bolt HH M10-1.50x20 C8.8 Z F	12
18	000-9173	Hitch plate	2
19	000-9201	Pin	2
20	009-1507	Hairpin cotter Ø4 Z	2
21	000-9264	Joint, double yoke	1
22	000-9590	Input shaft; 212, 215, 217-706	1
23	000-9223	Support UCP 207	1
24	002-3265	Bolt HH M12-1.75x40 C8.8 Z F	2
25	009-4139	Nut ES M12-1.75 TN Z	4
26	000-9424	Protection, shaft 212, 215, 217-706	1
	000-9701	Protection, shaft 212, 215, 217-706; since 04-1999	1
27	001-5255	Bolt HH M12-1.75x30 C8.8 Z F	2
28	000-9655	Rear hitch 212, 215, 217-706	1
29	000-9721	Transport hook	3
30	005-1740	Spring	2
31	000-9711	Hook support plate 212, 215, 217-706	1
32	007-3513	Bolt HH M16-2.00x60 C8.8 Z F	4
33	000-5581	Nut PT M16-2.00 C6 Z TK	4
34	000-9731	Bracket, unlocking handle	1
35	000-9476	Pulley, nylon	2
36	003-0331	Bolt HH M10-1.50x50 C8.8 Z F	2
37	003-0156	Nut PT M10-1.50 C6 TK Z	5
38	000-2034	Washer flat Ø10 W	4
39	009-1281	Bolt HH M10-1.50x35 C8.8 Z F	2
40	000-9737	Unlocking handle	1
41	003-8614	Bolt HH M10-1.50x40 C8.8 Z F	1
42	503-034B	Hydraulic cylinder	3
43	502-172B	Clip hairpin 0.105"x2.00" Z	12
44	502-171B	Pin hyd. cyl. 1.00"x3.40" Z	6
45	502-098B	Stand	1
46	000-1077	Washer lock Ø12 Z	4
47	000-6647	Cap	2

Ref.	Part #	Description	Qty.
52	000-9702	Protection extension, input shaft 212, 215, 217-706	1
53	007-6106	Washer fender Ø12 Z	1
54	002-3962	Hydraulic cylinder, unlock kit (option)	1
55	005-7114	Washer copper sealing Ø14	1
56	005-7113	Bolt hollow M14-1.50x28 Z	1
57	005-7111	Tube R1 1/4"x2300	1
58	004-1873	Nipple 3/8"-1/2"	1
59	004-1871	Quick connector 1/2"	1
60	002-3964	Jack fixing pin	1

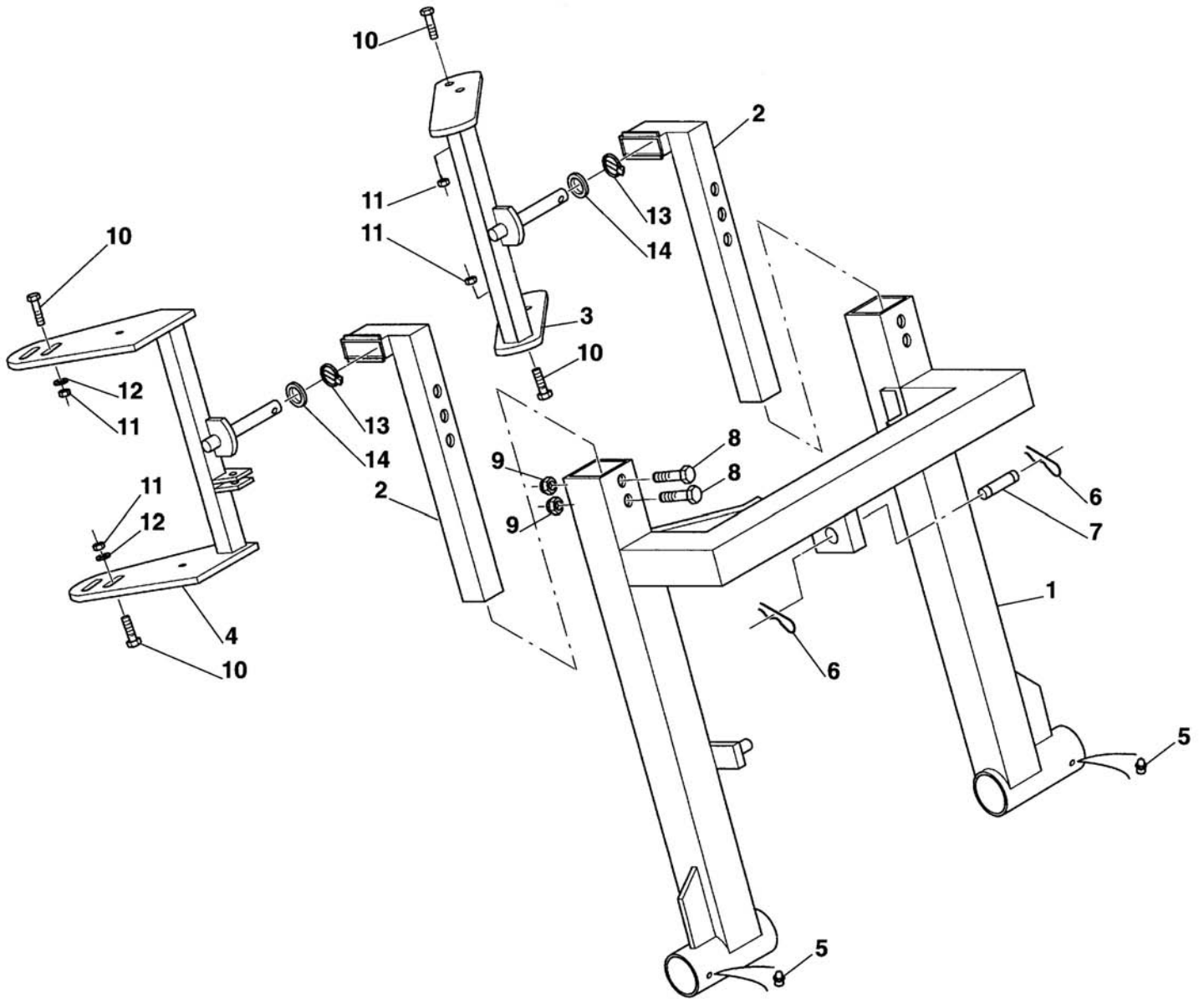

Ref.	Part #	Description	Qty.
1	010-9621	Frame, right lift; 212, 215, 217-706	1
	020-9621	Frame, left lift; 212, 215, 217-706	1
2	030-9461	Arm, right lift; 212, 215-706	2
	040-9461	Arm, left lift; 212, 215-706	2
	050-9461	Arm, right lift; 217-706	2
	060-9461	Arm, left lift; 217-706	2
3	000-9501	Rear hitch; 212-706	2
	000-9170	Rear hitch; 215, 217-706	2
4	010-9911	Front hitch, right; 212-706	1
	020-9911	Front hitch, left; 212-706	1
	030-9911	Front hitch, right; 215-706	1
	040-9911	Front hitch, left; 215-706	1
	050-9911	Front hitch, right; 217-706	1
	060-9911	Front hitch, left; 217-706	1
5	000-6635	Grease fitting Ø6 press in	4
6	502-172B	Clip hairpin 0.105'x2.00" Z	8
7	502-171B	Pin hyd. cyl. 1.00"x3.40" Z	4
8	000-5536	Bolt HH M14-2.00x90 C8.8 Z P	8
9	003-0358	Nut PT M14-2.00 C6 Z TK	8
10	003-3218	Bolt HH M16-2.00x55 C8.8 Z P	16
11	000-2366	Nut HH M16-2.00 C6 Z TK	16
12	000-8568	Washer flat Ø16 W	8
13	001-8266	Lynch pin Ø11x45	4
14	000-9159	Washer flat Ø36 Y	4

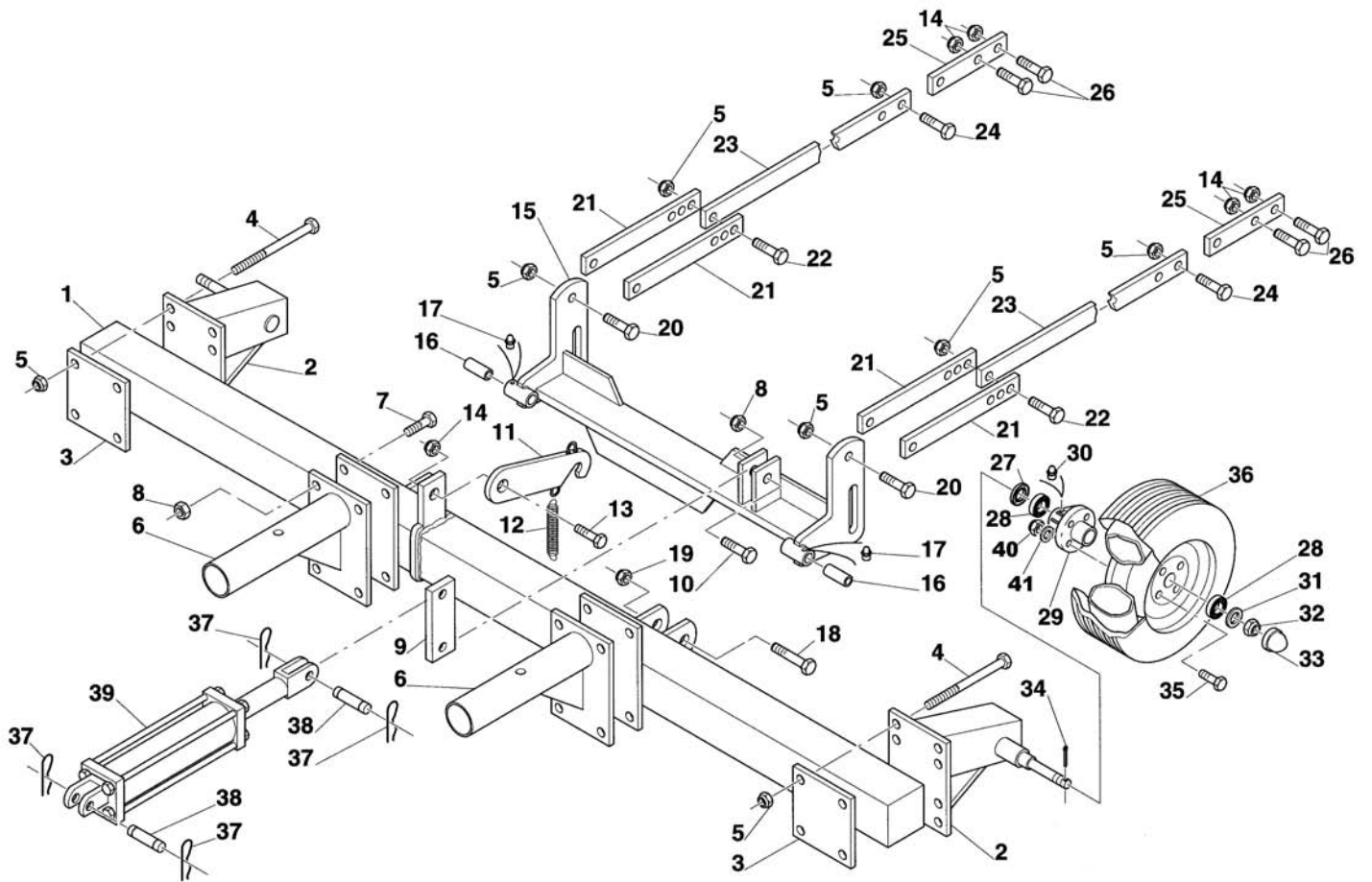

Ref.	Part #	Description	Qty.
1	000-9672	Frame, rear; 212, 215, 217-706	1
2	030-9761	Wheel support, right (spindle Ø25); 212, 215, 217-706 Ver. C	1
	010-9761	Wheel support, right (spindle Ø27); 212, 215, 217-706 Ver. D	1
	040-9761	Wheel support, left (spindle Ø25); 212, 215, 217-706 Ver. C	1
	020-9761	Wheel support, left (spindle Ø27); 212, 215, 217-706 Ver. D	1
3	000-9777	Back plate	2
4	000-6615	Bolt HH M14-2.00x140 C8.8 Z P	8
5	003-0358	Nut PT M14-2.00 C6 Z TK	14
6	000-9655	Rear hitch; 212, 215, 217-706	1
7	006-4377	Bolt HH M18-2.50x45 C8.8 Z F	8
8	001-7506	Nut PT M18-2.50 C6 Z TK	9
9	000-9180	Linkage, rear hydraulic cylinder; 212, 215, 217-706	1
10	002-6275	Bolt HH M18-2.50x70 C8.8 Z P	1
11	000-9721	Transport hook	1
12	000-9726	Spring	1
13	009-1038	Bolt HH M16-2.00x50 C8.8 Z F	1
14	000-5581	Nut PT M16-2.00 C6 Z TK	3
15	000-9831	Rear hitch; 212, 215, 217-706	1
16	000-9841	Spacer	2
17	000-6635	Grease fitting Ø6 press in	2
18	000-9843	Bolt HH M20-2.50x130 C8.8 Z P	2
19	000-5507	Nut PT M20-2.50 C6 TK Z	2
20	000-1018	Bolt HH M14-2.00x45 C8.8 Z P	2
21	000-9194	Tie rod joint	4
22	000-1526	Bolt HH M14-2.00x35 C8.8 Z F	2
23	000-9862	Tie rod, rear; 212, 215, 217-706	2
24	008-5168	Bolt HH M16-2.00x30 C8.8 Z F	2
25	000-9868	Hitch, tie rod; 212, 215, 217-706	2
26	003-2687	Bolt HH M16-2.00x40 C8.8 Z F	4
27	001-3705	Oil seal 35.52.10; 212, 215, 217-706 Ver. C	2
	502-097B	Oil seal 12192TB; 212, 215, 217-706 Ver. D	2
28	000-9771	Bearing 30205; 212, 215, 217-706 Ver. C	2
	502-102B	Bearing LM 44649/10; 212, 215, 217-706 Ver. D	2
29	000-9770	Hub, wheel; 212, 215, 217-706 Ver. C	2
	502-422B	Hub, wheel; 212, 215, 217-706 Ver. D	2
30	000-9760	Grease fitting M10-1.00	2
31	004-6555	Washer flat Ø20 Z	2
32	000-9768	Nut CA M20-2.50 C5 N TN	2
33	000-9769	Wheel cover; 212, 215, 217-706 Ver. C	2
	502-424B	Wheel cover; 212, 215, 217-706 Ver. D	2
34	004-4156	Cotter pin Ø4x25	2
35	003-7349	Bolt HH M14-2.00x45 C8.8 Z F; 212, 215, 217-706 Ver. C	10
	503-486B	Bolt LUG 1/2"-20x1.50" G5 Z; 212, 215, 217-706 Ver. D	12
36	190-2063	Wheel, complete	2
37	502-172B	Clip hairpin 0.105"x2.00" Z	4
38	502-171B	Pin hyd. cyl. 1.00"x3.40" Z	2
39	503-034B	Hydraulic cylinder	1
40	003-0358	Nut PT M14-2.00 C6 Z TK; 212, 215, 217-706 Ver. C	10
41	009-1435	Washer flat Ø14 W; 212, 215, 217-706 Ver. C	10

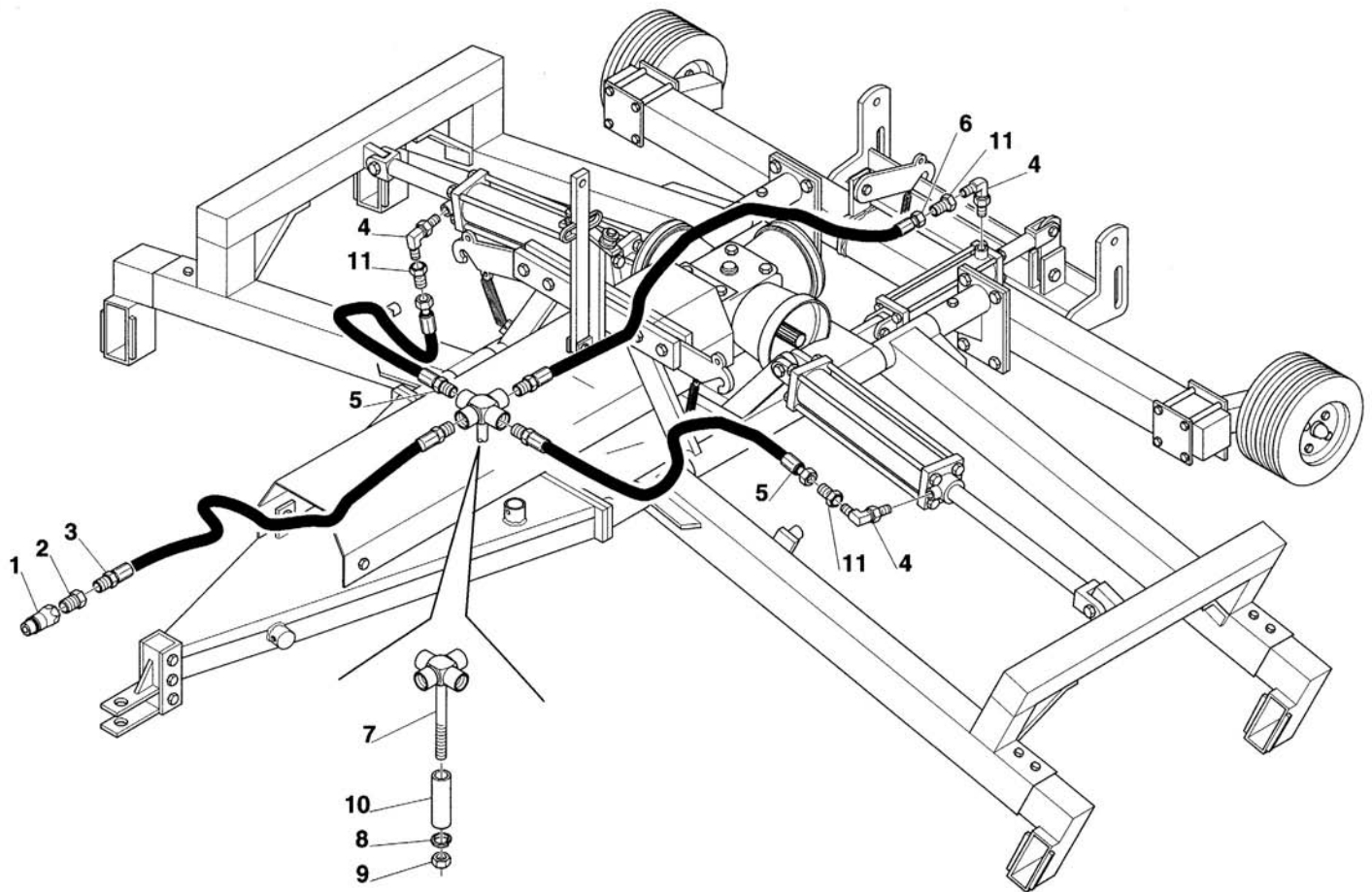

Ref.	Part #	Description	Qty.
1	502-170B	1/2" quick connect nipple 1/2" FP	1
2	502-169B	Reducer 3/8"-1/2"	1
3	502-166B	Hydraulic hose 87", front	1
4	502-163B	90° OR fitting	3
5	502-168B	Hydraulic hose 39", side	2
6	502-167B	Hydraulic hose 60", rear	1
7	502-165B	Hyd. cross 3/8" MNPT	1
8	000-1077	Washer lock Ø12 Z	1
9	000-3038	Nut HH M12-1.75 C6 Z TK	1
10	002-1285	Spacer	1
11	502-164B	Adaptor 3/8" NPT with 1/16" restrictor	3

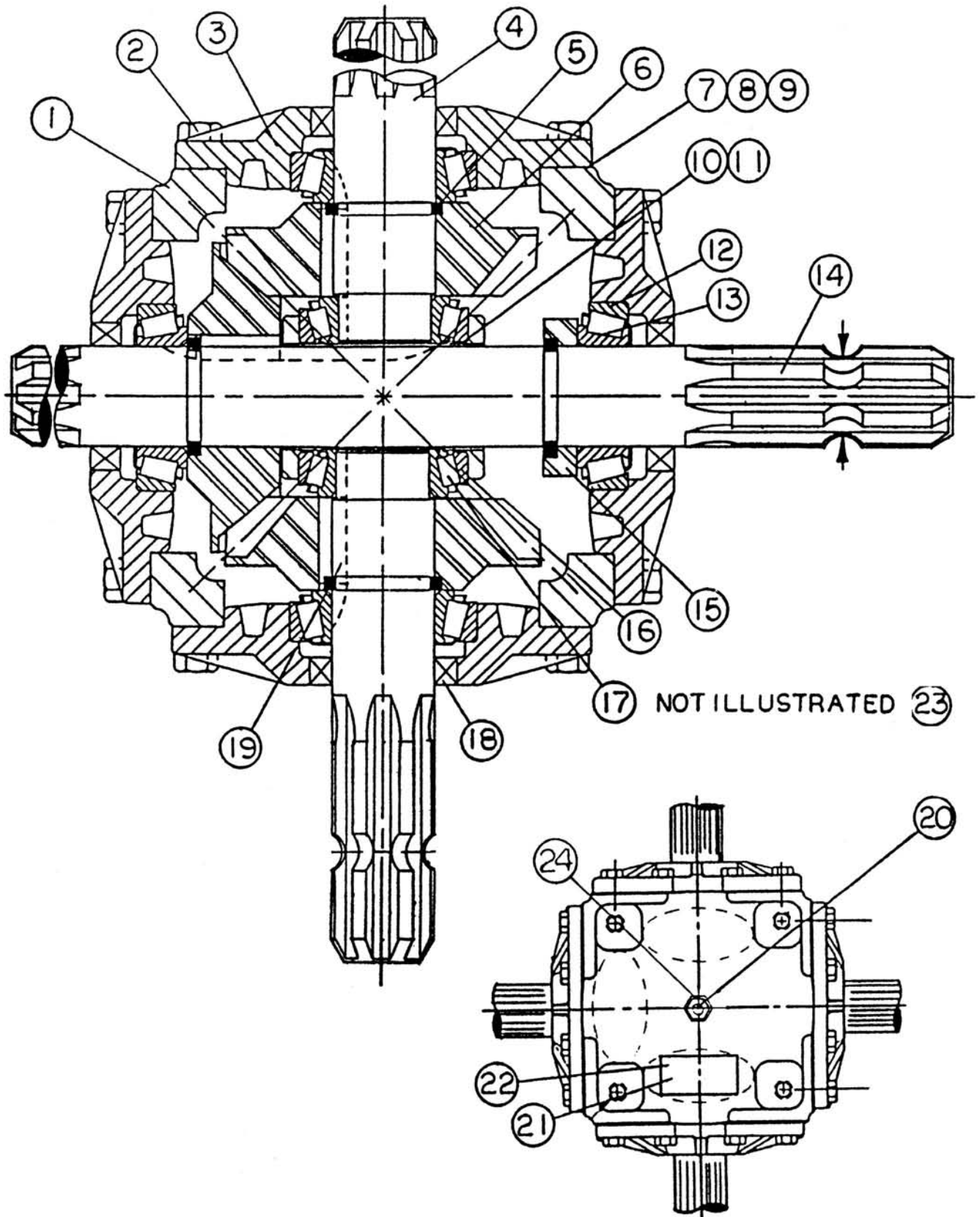

Ref.	Part #	Description	Qty.
1	502-124B	Housing, gearbox	1
2	502-125B	Bolt SL M08-1.40x25 N F	32
3	502-126B	Cap	4
4	502-127B	Input shaft, short	2
5	502-128B	Retaining ring	4
6	502-129B	Gear	3
7	502-130B	Gasket (0.015)	-
8	502-131B	Gasket (0.005)	-
9	502-132B	Gasket (0.003)	-
10	502-133B	Shim (0.005)	-
11	502-134B	Shim (0.010)	-
12	502-135B	Bearing cup LM 48510	4
13	502-136B	Bearing cone LM 48548	4
14	502-137B	Input shaft, long	1
15	502-138B	Collar	1
16	501-727B	Bearing cup LM 67010	2
17	501-728B	Bearing cone LM 67048	2
18	502-139B	Oil seal 13203TA	4
19	502-140B	Key	3
20	502-141B	Breather cap	1
21	502-142B	I.D. tag	1
22	502-143B	I.D. cover	1
23	502-144B	Pipe plug	1
24	502-145B	Reducer bushing	1
	502-146B	Main gearbox, complete	-

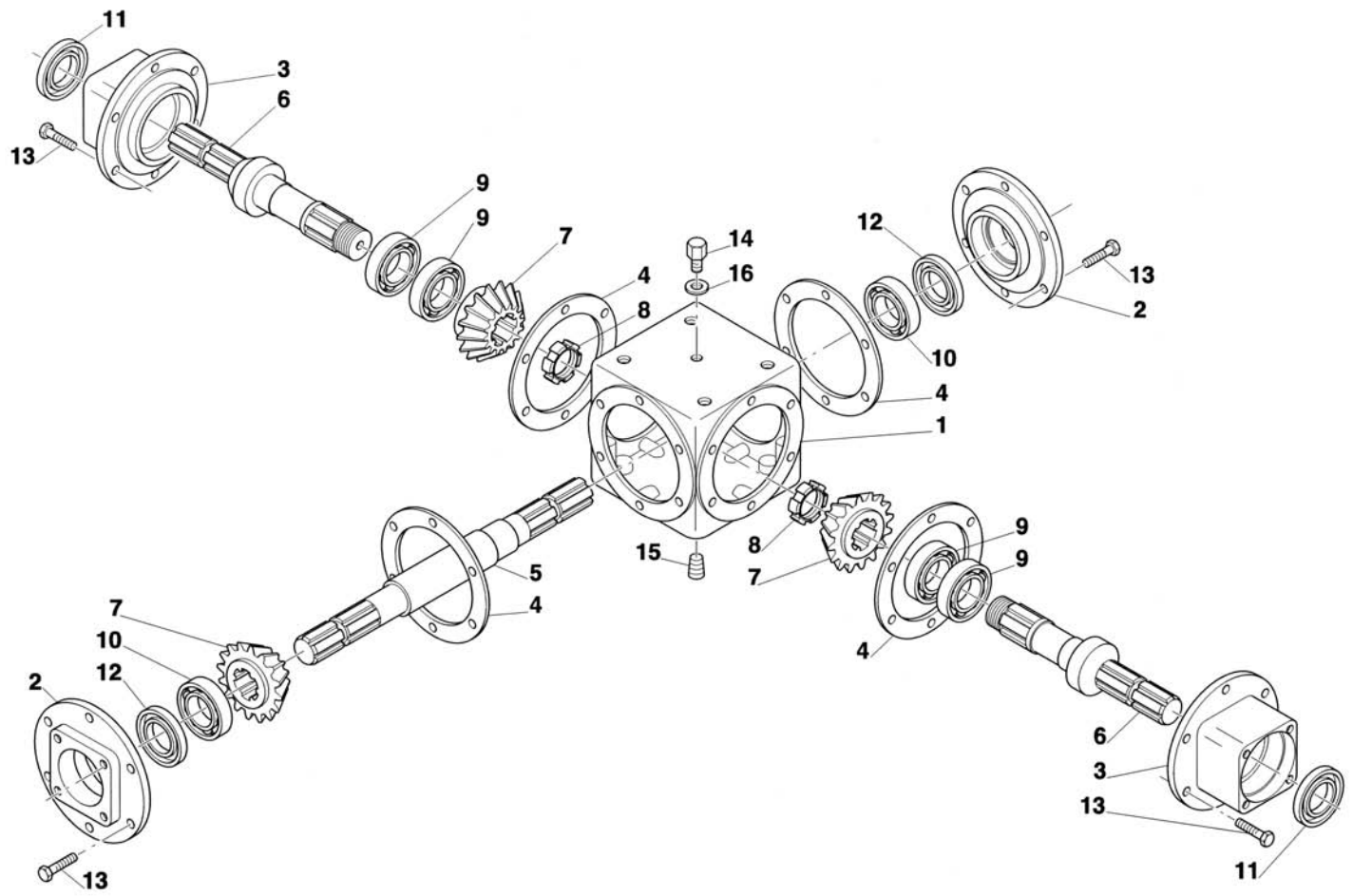

Ref.	Part #	Description	Qty.
1	000-9970	Housing, gearbox	1
2	000-9971	Front cover, gearbox housing	2
3	000-9972	Side support, gearbox housing	2
4	003-0193	Gasket 2/10	-
	013-0193	Gasket 5/10	-
5	000-9975	Input shaft	1
6	000-9976	Output shaft	2
7	000-9973	Ring gear	3
8	003-7098	Locking ring ES GUK M35-1.50	2
9	003-0201	Bearing 30208	4
10	000-7172A	Bearing 30207	2
11	000-7094	Oil seal 52.85.10	2
12	000-9974	Oil seal 35.55.10	2
13	000-1241	Bolt HH M10-1.50x25 C8.8 N F	24
14	000-1107A	Breather cap	1
15	005-3446	Drain plug	1
16	000-6691	Gasket	1
	050-0617	Main gearbox, complete	-

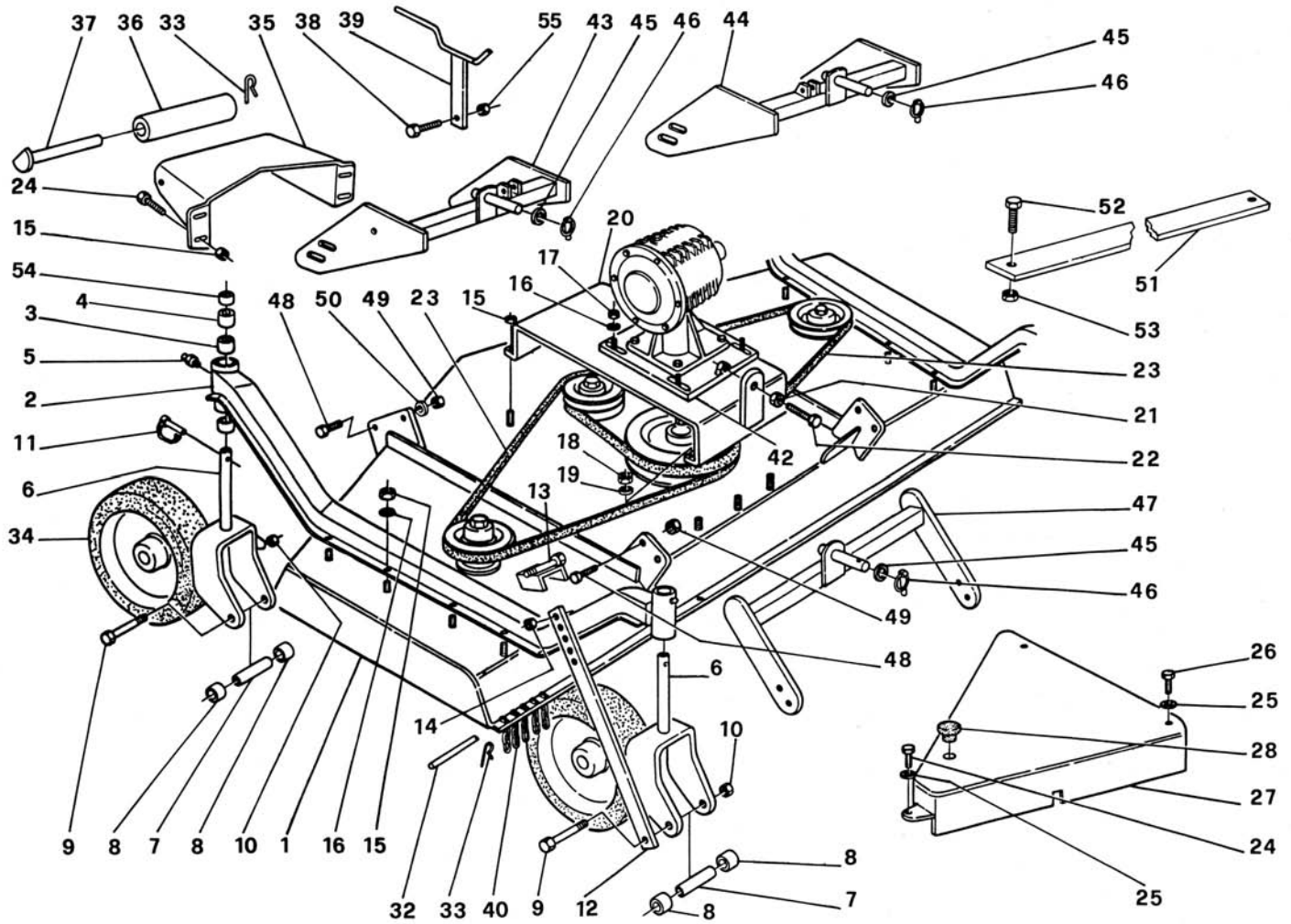

Ref.	Part #	Description	Qty.
1	010-6903	Frame 4' deck; 212-706	2
	020-6903	Frame 5' deck; 215-706	2
	030-6900	Frame 6' deck; 217-706	2
2	010-6939	Wheel arm 4' deck; 212-706	2
	020-6939	Wheel arm 5' deck; 215-706	2
	030-6932	Wheel arm 6' deck; 217-706	2
3	000-6586	Spacer 1"	12
4	000-6587	Spacer 1/2"	4
5	000-1065	Grease fitting M10-1.00	4
6	000-6946	Wheel yoke	4
7	000-6584	Inner spacer, hard tire #000-6923Y	4
	502-093B	Inner spacer, air tire #502-193B; 212, 215, 217-706 Ver. L & below	4
	000-6584	Inner spacer, air tire #000-6967; 212, 215, 217-706 Ver. M & above	4
8	000-6585	Outer spacer, hard tire #000-6923Y	8
	502-196B	Washer flat Ø20 Z, air tire #502-193B; 212, 215, 217-706 Ver. L & below	8
	000-6585	Outer spacer, air tire #000-6967; 212, 215, 217-706 Ver. M & above	8
9	000-6619	Bolt HH M14-2.00x150 C8.8 Z P	4
10	003-0358	Nut PT M14-2.00 C6 Z TK	4
11	000-6610	Lynch pin Ø6x46	4
	000-8783	Pin, wheel yoke; since 07-1999	4
12	000-9692	Locking plate	1
13	000-9694	Wheel support	1
14	000-1019	Nut HH M14-2.00 C6 TK Z	1
15	003-0156	Nut PT M10-1.50 C6 TK Z	22
16	003-0157	Washer fender Ø10 Z	20
17	001-4106	Nut ES M10-1.50 Z TK	4
18	000-1279	Nut HH M10-1.50 C6 TK Z	3
19	000-1280	Washer lock Ø10 Z	3
20	000-6904	Central plate, 4' deck; 212-706	1
	000-6875	Central plate, 5' deck; 215-706	1
	000-6913	Central plate, 6' deck; 217-706	1
21	000-1106	Nut HH M12-1.75 C6 Z MD	2
22	000-6547	Bolt HH M12-1.75x100 C8.8 Z F	1
23	000-6798	Belt 5VX630, 4' deck: 212-706	2
	000-6693	Belt 5VX710, 5' deck: 215-706	2
	000-6848	Belt 5VX850, 6' deck: 217-706	2
24	000-6349	Bolt HH M10-1.50x20 C8.8 Z F	10
25	000-2034	Washer flat Ø10 W	10
26	003-3176	Bolt HH M10-1.50x25 C8.8 Z F	4
27	010-6987	Belt shield 4' deck, 212-706	2
	020-6987	Belt shield 5' deck, 215-706	2
	030-6975	Belt shield 6' deck, 217-706	2
28	000-6647	Cap	3
32	010-6762	Chain rod, 4' deck; 212-706	1
	020-6762	Chain rod, 5' deck; 215-706	1
	030-6762	Chain rod, 6' deck; 217-706	1
33	004-4156	Cotter pin Ø4x25	2

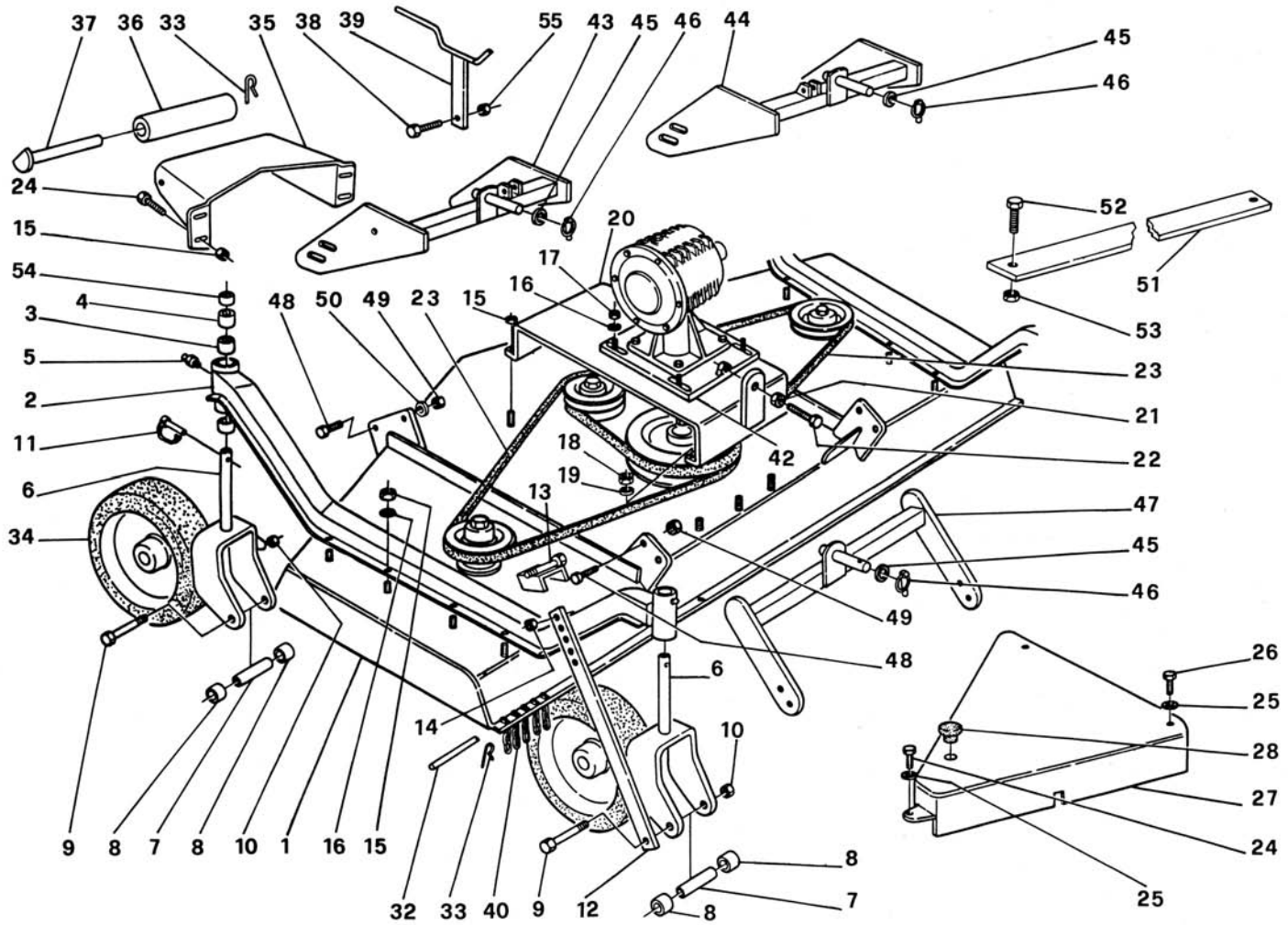

Ref.	Part #	Description	Qty.
34	000-6923Y	Wheel, hard tire	4
	502-193B	Wheel, air tire; 212, 215, 217-706 Ver. L & below	4
	000-6967	Wheel, air tire; 212, 215, 217-706 Ver. M & above	4
35	000-9622	Front roller support	1
36	006-7358	Roller 3"	1
37	006-7363	Roller pin	1
38	000-7716	Bolt HH M12-1.75x45 C8.8 Z F	1
39	000-9825	Kick-out bracket	1
40	000-6764	Chain link	-
42	000-6541	Gearbox support plate	1
43	020-9911	Front hitch, left 4' deck; 212-706	1
	040-9911	Front hitch, left 5' deck; 215-706	1
	060-9911	Front hitch, left 6' deck; 217-706	1
44	010-9911	Front hitch, right 4' deck; 212-706	1
	030-9911	Front hitch, right 5' deck; 215-706	1
	050-9911	Front hitch, right 6' deck; 217-706	1
45	000-8568	Washer flat Ø16 W	2
46	001-8266	Lynch pin Ø11x45	2
47	000-9501	Rear hitch 4' deck; 212-706	1
	000-9170	Rear hitch 5' & 6' deck; 215, 217-706	1
48	003-3218	Bolt HH M16-2.00x55 C8.8 Z P	8
49	000-2366	Nut HH M16-2.00 C6 Z TK	8
50	000-8568	Washer flat Ø16 W	4
51	010-9961	Safety tie rod; 212-706	1
	020-9961	Safety tie rod; 215-706	1
	030-9961	Safety tie rod; 217-706	1
52	002-3265	Bolt HH M12-1.75x40 C8.8 Z F	2
53	001-3345	Nut ES M12-1.75 Z TK	2
54	000-6589	Spacer 1/4"	8
55	003-0064	Nut PT M12-1.75 C6 TK Z	2

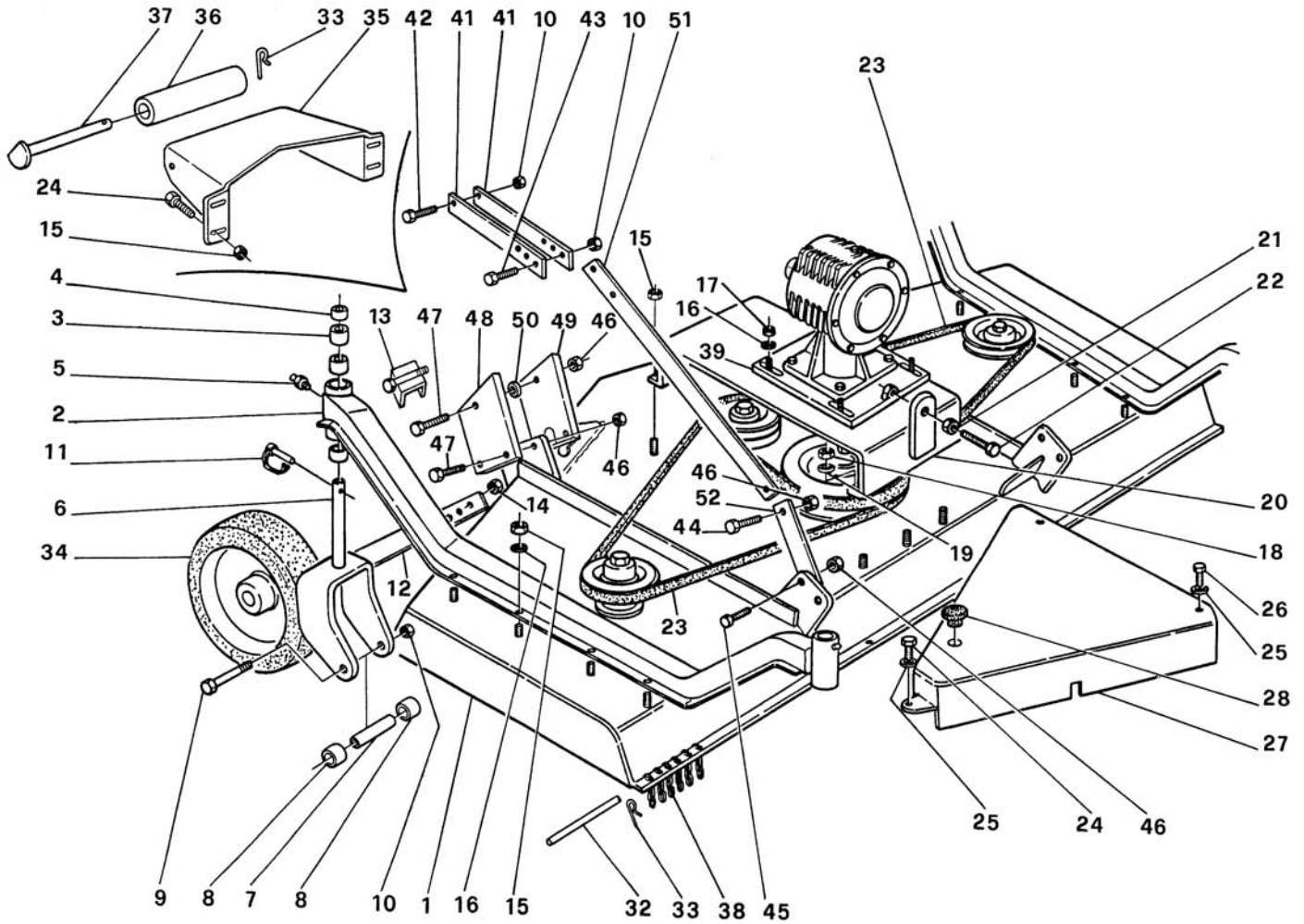

Ref.	Part #	Description	Qty.
1	020-6903	Frame 5' deck; 212-706	1
	030-6900	Frame 6' deck; 215, 217-706	1
2	020-6939	Wheel arm 5' deck; 212-706	2
	030-6932	Wheel arm 6' deck; 215, 217-706	2
3	000-6586	Spacer 1"	12
4	000-6587	Spacer 1/2"	4
5	000-1065	Grease fitting M10-1.00	4
6	000-6946	Wheel yoke	4
7	000-6584	Inner spacer, hard tire #000-6923Y	4
	502-093B	Inner spacer, air tire #502-193B; 212, 215, 217-706 Ver. L & below	4
	000-6584	Inner spacer, air tire #000-6967; 212, 215, 217-706 Ver. M & above	4
8	000-6585	Outer spacer, hard tire #000-6923Y	8
	502-196B	Washer flat Ø20 Z, air tire #502-193B; 212, 215, 217-706 Ver. L & below	8
	000-6585	Outer spacer, air tire #000-6967; 212, 215, 217-706 Ver. M & above	8
9	000-6619	Bolt HH M14-2.00x150 C8.8 Z P	4
10	003-0358	Nut PT M14-2.00 C6 Z TK	4
11	000-6610	Lynch pin Ø6x46	4
	000-8783	Pin, wheel yoke; since 07-1999	4
12	000-9692	Locking plate	2
13	000-9694	Wheel support	2
14	000-1019	Nut HH M14-2.00 C6 TK Z	1
15	003-0156	Nut PT M10-1.50 C6 TK Z	23
16	003-0157	Washer fender Ø10 Z	20
17	001-4106	Nut ES M10-1.50 Z TK	4
18	000-1279	Nut HH M10-1.50 C6 TK Z	3
19	000-1280	Washer lock Ø10 Z	3
20	000-6875	Central plate, 5' deck; 212-706	1
	000-6913	Central plate, 6' deck; 215, 217-706	1
21	000-1106	Nut HH M12-1.75 C6 Z MD	2
22	000-6547	Bolt HH M12-1.75x100 C8.8 Z F	1
23	000-6693	Belt 5VX710, 5' deck: 212-706	2
	000-6848	Belt 5VX850, 6' deck: 215, 217-706	2
24	000-6349	Bolt HH M10-1.50x20 C8.8 Z F	10
25	000-2034	Washer flat Ø10 W	10
26	003-3176	Bolt HH M10-1.50x25 C8.8 Z F	4
27	020-6987	Belt shield 5' deck, 212-706	2
	030-6975	Belt shield 6' deck, 215, 217-706	2
28	000-6647	Cap	3
32	020-6762	Chain rod, 5' deck; 212-706	1
	030-6762	Chain rod, 6' deck; 215, 217-706	1
33	004-4156	Cotter pin Ø4x25	2
34	000-6923Y	Wheel, hard tire	4
	502-193B	Wheel, air tire; 212, 215, 217-706 Ver. L & below	4
	000-6967	Wheel, air tire; 212, 215, 217-706 Ver. M & above	4
35	000-9622	Front roller support	1
36	006-7358	Roller 3"	1
37	006-7363	Roller pin	1

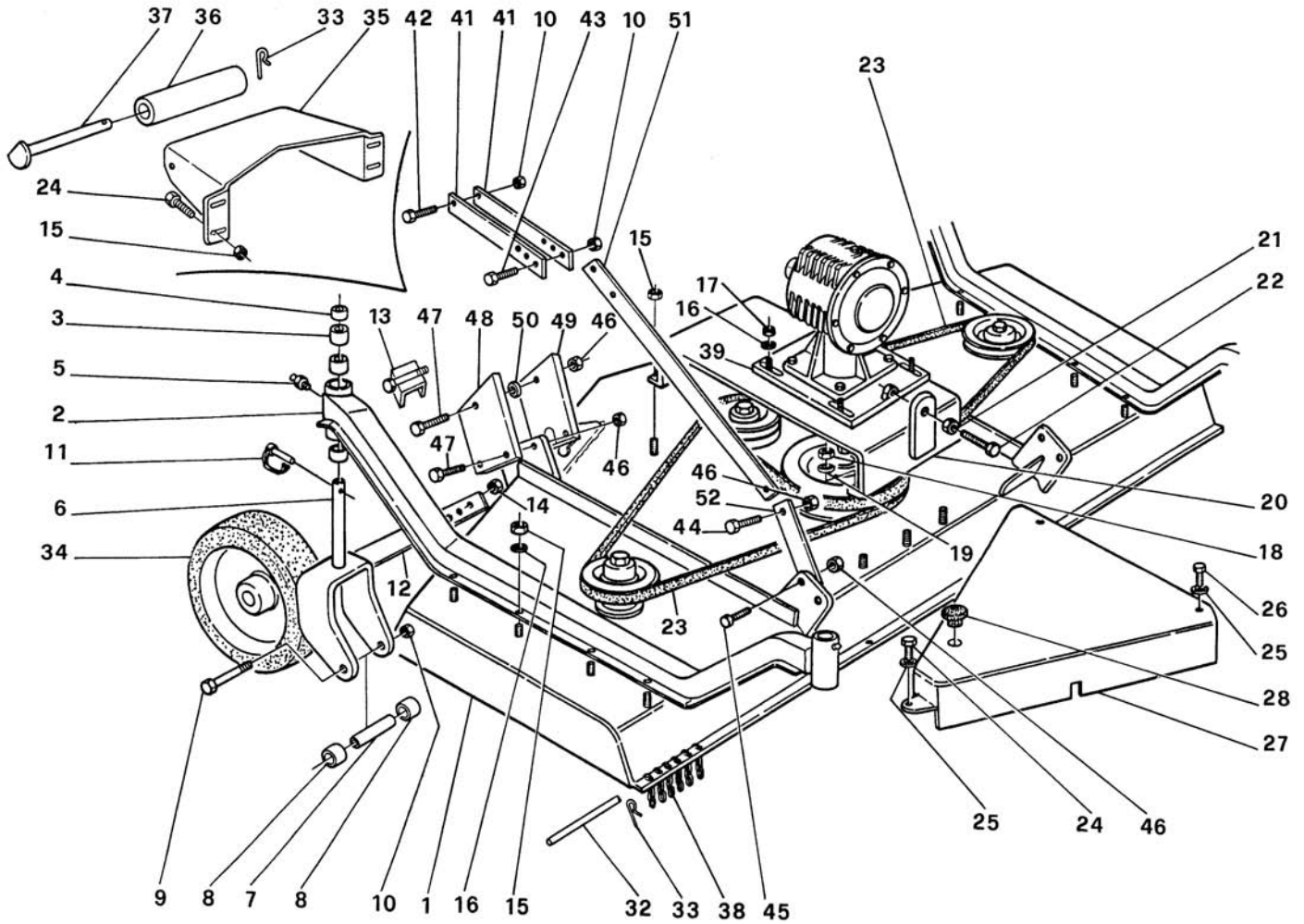

Ref.	Part #	Description	Qty.
38	000-6764	Chain link	-
39	000-6541	Gearbox support plate	1
41	000-9194	Tie rod joint	4
42	000-1018	Bolt HH M14-2.00x45 C8.8 Z P	2
43	000-1526	Bolt HH M14-2.00x35 C8.8 Z F	2
44	008-5168	Bolt HH M16-2.00x30 C8.8 Z F	2
45	003-2687	Bolt HH M16-2.00x40 C8.8 Z F	4
46	000-5581	Nut PT M16-2.00 C6 Z TK	12
47	003-2687	Bolt HH M16-2.00x40 C8.8 Z F	6
	000-9884	Bolt HH M16-2.00x65 C8.8 Z F	6
48	010-9882	Hitch plate	2
49	020-9882	Hitch plate	2
50	000-9846	Spacer	2
51	000-9862	Tie rod, rear	2
52	000-9868	Hitch, tie rod	2
53	000-6589	Spacer 1/4"	8

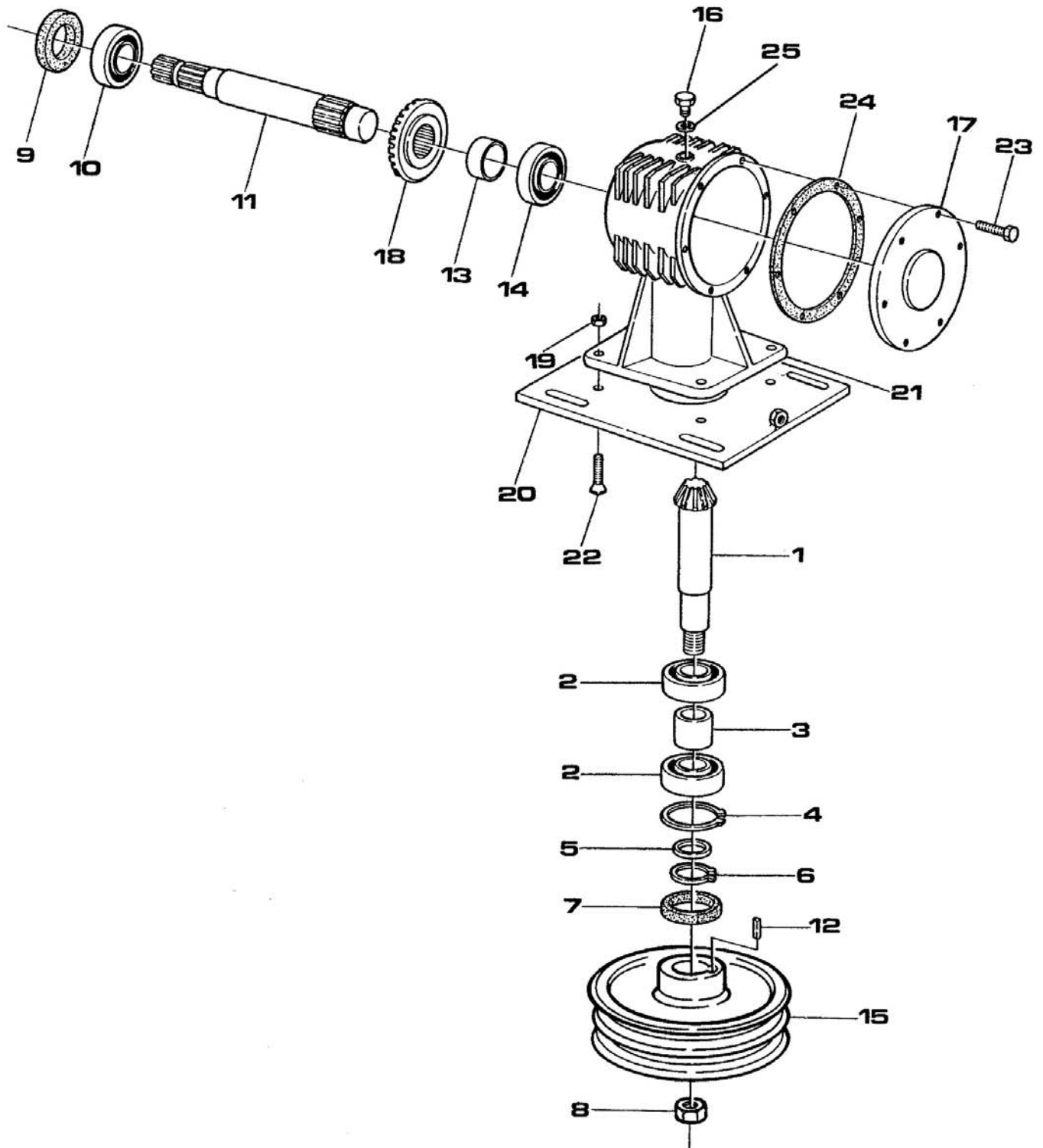

Ref.	Part #	Description	Qty.
1	000-6676	Pinion gear, straight gears	1
2	001-2149A	Bearing 6208	2
3	000-6687	Spacer	1
4	000-1154	Snap ring, inner Ø80	1
5	000-6685	Shim Ø40x50x2.5	1
6	000-8138	Snap ring, outer Ø40	1
7	000-6684	Oil seal 40.80.10	1
8	000-6698	Nut SP M25-1.50 Z	1
9	000-2295	Oil seal 35.62.10	1
10	002-5332A	Bearing 6207	1
11	000-6657	Input shaft	1
12	000-6689	Key 8x7x30	1
13	000-6667	Rear spacer	1
	000-6661	Rear spacer; since 09-1997	1
14	000-2292	Bearing 6305	1
	004-4217	Bearing 30305; since 09-1997	1
15	000-6692	Pulley SPB 250x2	1
16	000-1107A	Breather cap	1
17	000-6656	Cover, gearbox housing	1
18	000-6677	Ring gear, straight gears	1
19	003-0064	Nut PT M12-1.75 C6 TK Z	4
20	000-6541	Support plate, gearbox housing	1
21	000-6658	Housing, gearbox	1
22	004-6334	Bolt CS M12-1.75x45 C10.9 N F	4
23	000-6349	Bolt HH M10-1.50x20 C8.8 Z F	6
24	003-0193	Gasket 2/10	-
	013-0193	Gasket 5/10	-
25	000-6691	Gasket, aluminum	1
	050-0607	Gearbox 540 rpm, complete ¹	-
	050-0638	Gearbox 540 rpm, complete; since 09-1997 ²	-

¹ Interchangeable with complete gearbox #050-0642.

² Interchangeable with complete gearbox #050-0642.

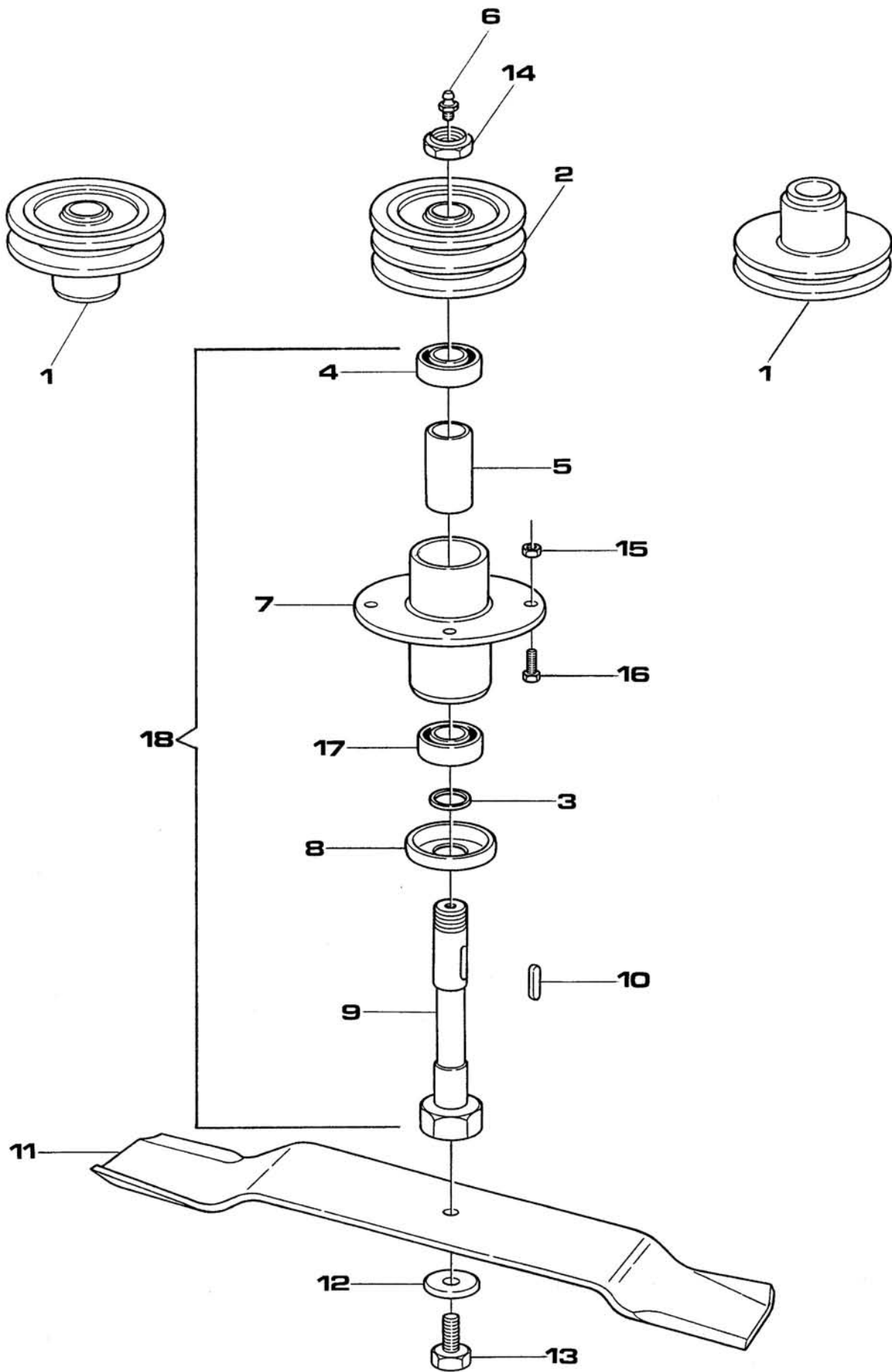

Ref.	Part #	Description	Qty.
1	000-6792	Pulley SPB 120x1, 4' deck	2
	000-6622	Pulley SPB 130x1, 5' deck	2
	000-6842	Pulley SPB 160x1, 6' deck	2
2	000-6791	Pulley SPB 120x2, 4' deck	1
	000-6621	Pulley SPB 130x2, 5' deck	1
	000-6841	Pulley SPB 160x2, 6' deck	1
3	000-6606	Shim Ø25x35x2	3
4	000-6634A	Bearing 6205-Z	3
5	000-6640	Spacer	3
6	002-9036	Grease fitting Ø8 press in	3
7	000-6648	Rotor support	3
8	000-6636	Cover	3
9	000-6649	Blade holder shaft	3
10	000-6639	Key 7x8x25	3
11	000-6795	Blade, standard 4' deck	3
	000-6641	Blade, standard 5' deck	3
	000-6845	Blade, standard 6' deck	3
	000-6795M	Blade, mulching 4' deck (option)	3
	000-6641M	Blade, mulching 5' deck (option)	3
	000-6845M	Blade, mulching 6' deck (option)	3
	000-6795B	Blade, highlift 4' deck (option)	3
	000-6641B	Blade, highlift 5' deck (option)	3
	000-6845B	Blade, highlift 6' deck (option)	3
	000-6795F	Blade, flat 4' deck (option)	3
	000-6641F	Blade, flat 5' deck (option)	3
	000-6845F	Blade, flat 6' deck (option)	3
	000-6795G	Blade, gator 4' deck (option)	3
	000-6641G	Blade, gator 5' deck (option)	3
	000-6845G	Blade, gator 6' deck (option)	3
12	000-8560	Washer conical spring Ø18 Z	3
13	000-8559	Bolt blade SP M14-1.50x32	3
14	000-6698	Nut SP M25-1.50 Z	3
15	003-0156	Nut PT M10-1.50 C6 TK Z	12
16	000-1008	Bolt HH M10-1.50x30 C8.8 N F	12
17	000-6626A	Bearing 6205-ZZ	3
18	000-6629C	Spindle, complete	3

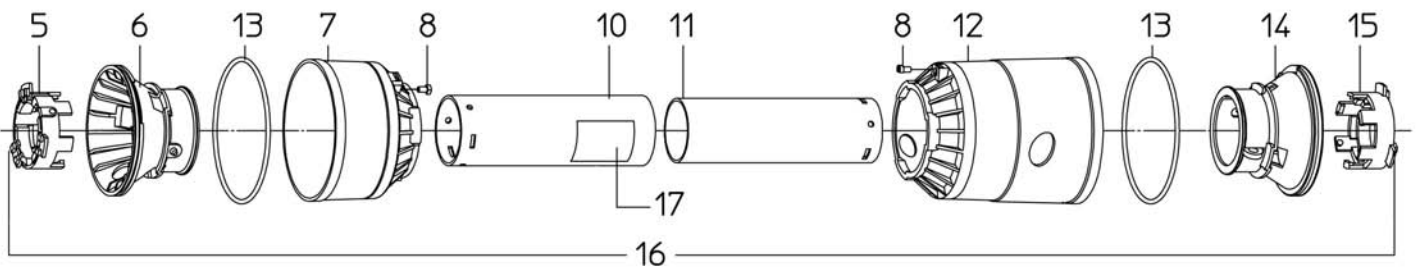
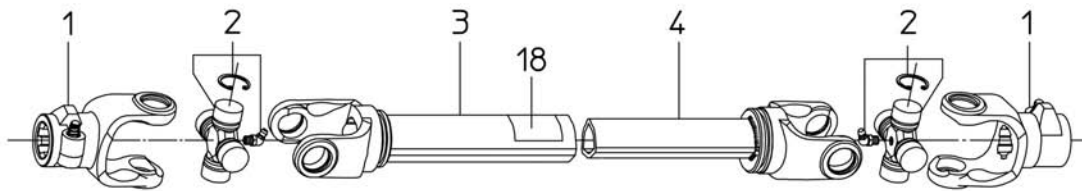

Ref.	Part #	Description	Qty.
1	1023010C	PTO yoke	1
2	1003020C	Cross & bearing	2
3	1943042NC	Outer tube	1
4	1953044NC	Inner tube	1
5	1784210C	Locking ring, outer tube	1
6	1784201C	Rigid cone, outer tube	1
7	1784203C	Standard cone	1
8	1784212C	Pin	2
9	1006065C	Chain, anti-rotation	2
10	1773040C	Shield, outer tube	1
11	1872040C	Shield, inner tube	1
12	1784205C	Long cone	1
13	1213233C	Stiffening ring	2
14	1784202C	Rigid cone, inner tube	1
15	1784211C	Locking ring, inner tube	1
16	90SL4040C	Shield, complete ³	1
17	950-463B	Decal "DANGER - Rotating driveline, keep away", outer shield	1
18	950-464B	Decal "DANGER - Guard missing, do not operate", outer tube	1
	050-0413	Driveline, complete	-

³ Complete shielding is interchangeable with part #96SL4040C.

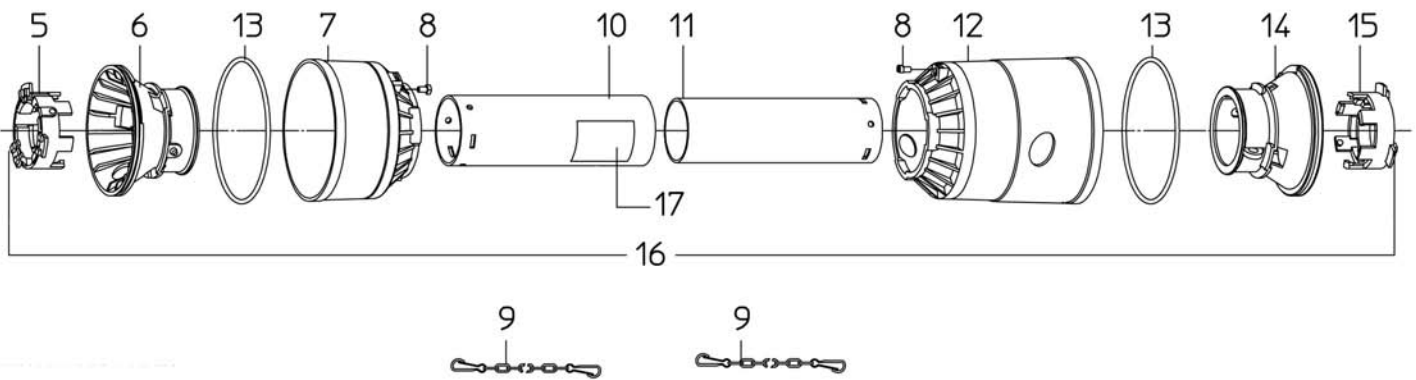
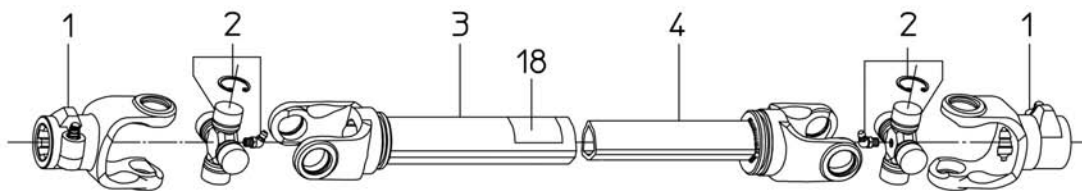

Ref.	Part #	Description	Qty.
1	1023010C	PTO yoke	1
2	1003020C	Cross & bearing	2
3	1943055NC	Outer tube	1
4	1953057NC	Inner tube	1
5	1784210C	Locking ring, outer tube	1
6	1784201C	Rigid cone, outer tube	1
7	1784203C	Standard cone	1
8	1784212C	Pin	2
9	1006065C	Chain, anti-rotation	2
10	1773053C	Shield, outer tube	1
11	1872053C	Shield, inner tube	1
12	1784205C	Long cone	1
13	1213233C	Stiffening ring	2
14	1784202C	Rigid cone, inner tube	1
15	1784211C	Locking ring, inner tube	1
16	90SL4053C	Shield, complete ⁴	1
17	950-463B	Decal "DANGER - Rotating driveline, keep away", outer shield	1
18	950-464B	Decal "DANGER - Guard missing, do not operate", outer tube	1
	050-0414	Driveline, complete	-

⁴ Complete shielding is interchangeable with part #96SL4053C.

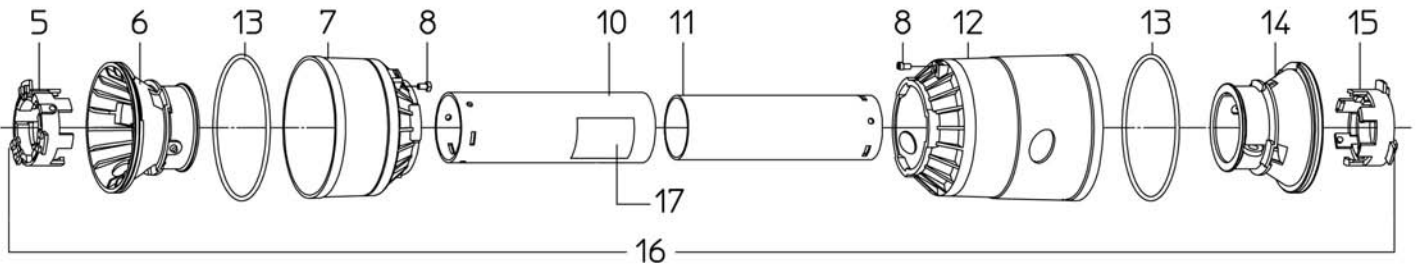
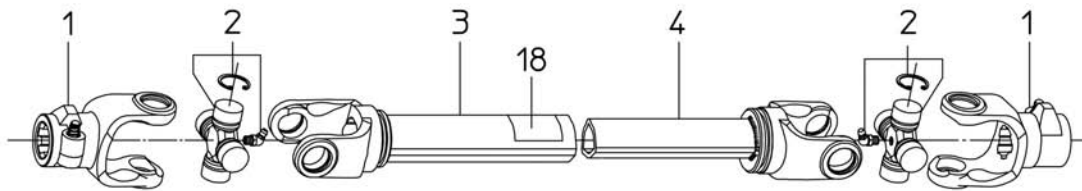

Ref.	Part #	Description	Qty.
1	1023010C	PTO yoke	1
2	1003020C	Cross & bearing	2
3	1943070NC	Outer tube	1
4	1953072NC	Inner tube	1
5	1784210C	Locking ring, outer tube	1
6	1784201C	Rigid cone, outer tube	1
7	1784203C	Standard cone	1
8	1784212C	Pin	2
9	1006065C	Chain, anti-rotation	2
10	1773068C	Shield, outer tube	1
11	1872068C	Shield, inner tube	1
12	1784205C	Long cone	1
13	1213233C	Stiffening ring	2
14	1784202C	Rigid cone, inner tube	1
15	1784211C	Locking ring, inner tube	1
16	90SL4068C	Shield, complete ⁵	1
17	950-463B	Decal "DANGER - Rotating driveline, keep away", outer shield	1
18	950-464B	Decal "DANGER - Guard missing, do not operate", outer tube	1
	050-0415	Driveline, complete	-

⁵ Complete shielding is interchangeable with part #96SL4068C.

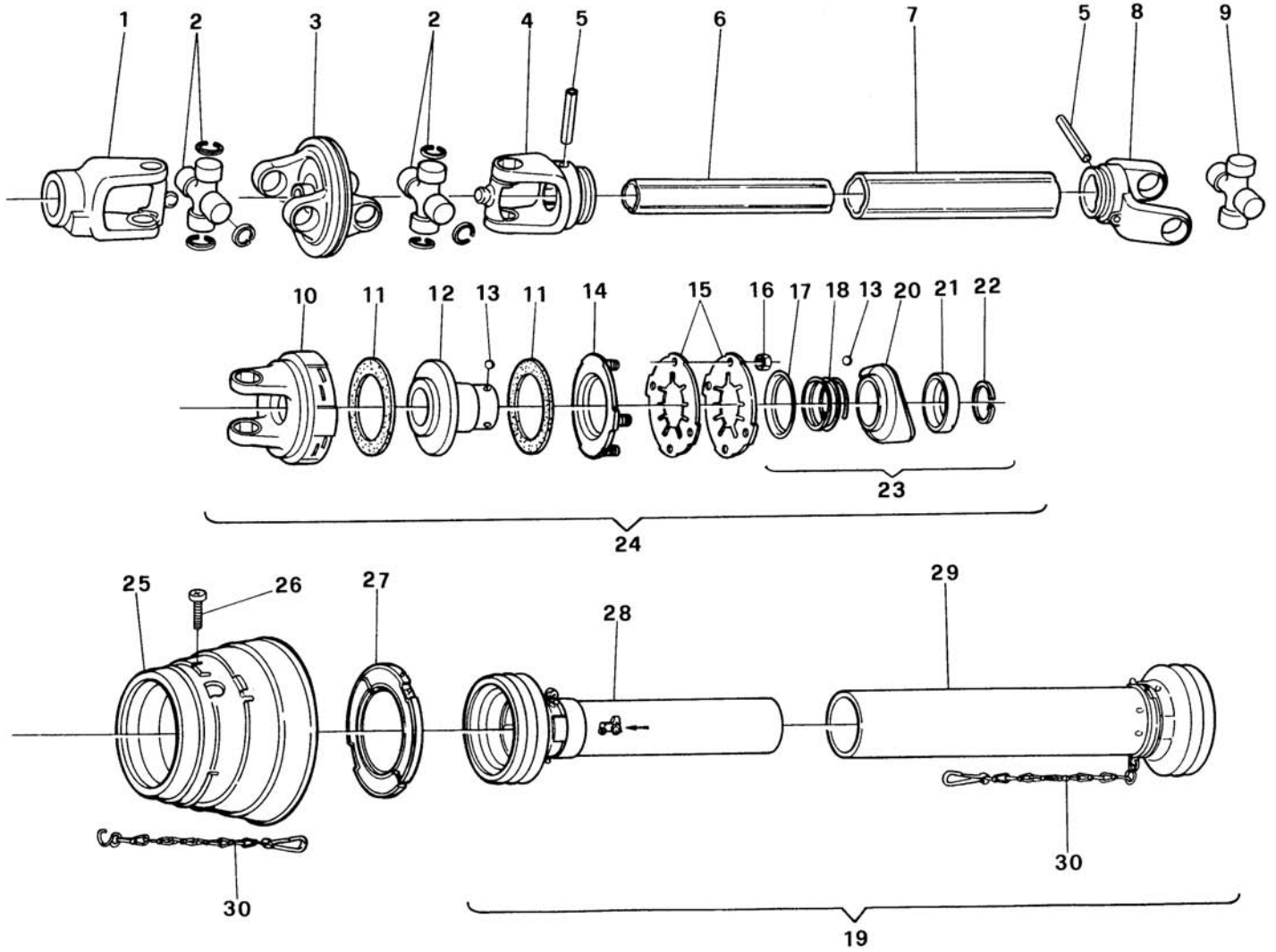

Ref.	Part #	Description	Qty.
1	341579W	PTO yoke WWE 2480	1
2	342221W	Cross & bearing WWE 2480	2
3	365722W	Double yoke WWE 2480	1
4	341586W	Yoke WWE 2480	1
5	020617W	Roll pin WWE 2480	2
6	095400W	Inner tube WWE 2480	1
7	096890W	Outer tube WWE 2480	1
8	019519W	Yoke WWE 2480	1
9	312410W	Cross & bearing WWE 2480	1
10	321715W	Clutch housing WWE 2480	1
11	168556W	Friction disc	2
12	051551W	Rotor	1
13	020692W	Lock roller	6
14	381495W	Thrust plate	1
15	043489W	Disc spring	2
16	381957W	Nut	4
17	047825W	Back up ring	1
18	045793W	Spring	1
19	106724W	Shield, complete	1
20	045790W	Bushing	1
21	338531W	Back up ring	1
22	304149W	Snap ring	1
23	341953W	Quick disconnecting lock	1
24	321714W	Slip clutch, complete WWE 2480	1
25	172717W	Protection WWE 2480	1
26	365305W	Bolt	6
27	172715W	Bearing ring WWE 2480	1
28	183570W	Protection, outer WWE 2480	1
29	368508W	Protection, inner	1
30	044321W	Chain, anti-rotation	2
	050-0036	Main driveline WWE 2480, complete	-
	950-463B	Decal "DANGER - Rotating driveline, keep away" outer shield	1
	950-464B	Decal "DANGER - Guard missing, do not operate" outer tube	1

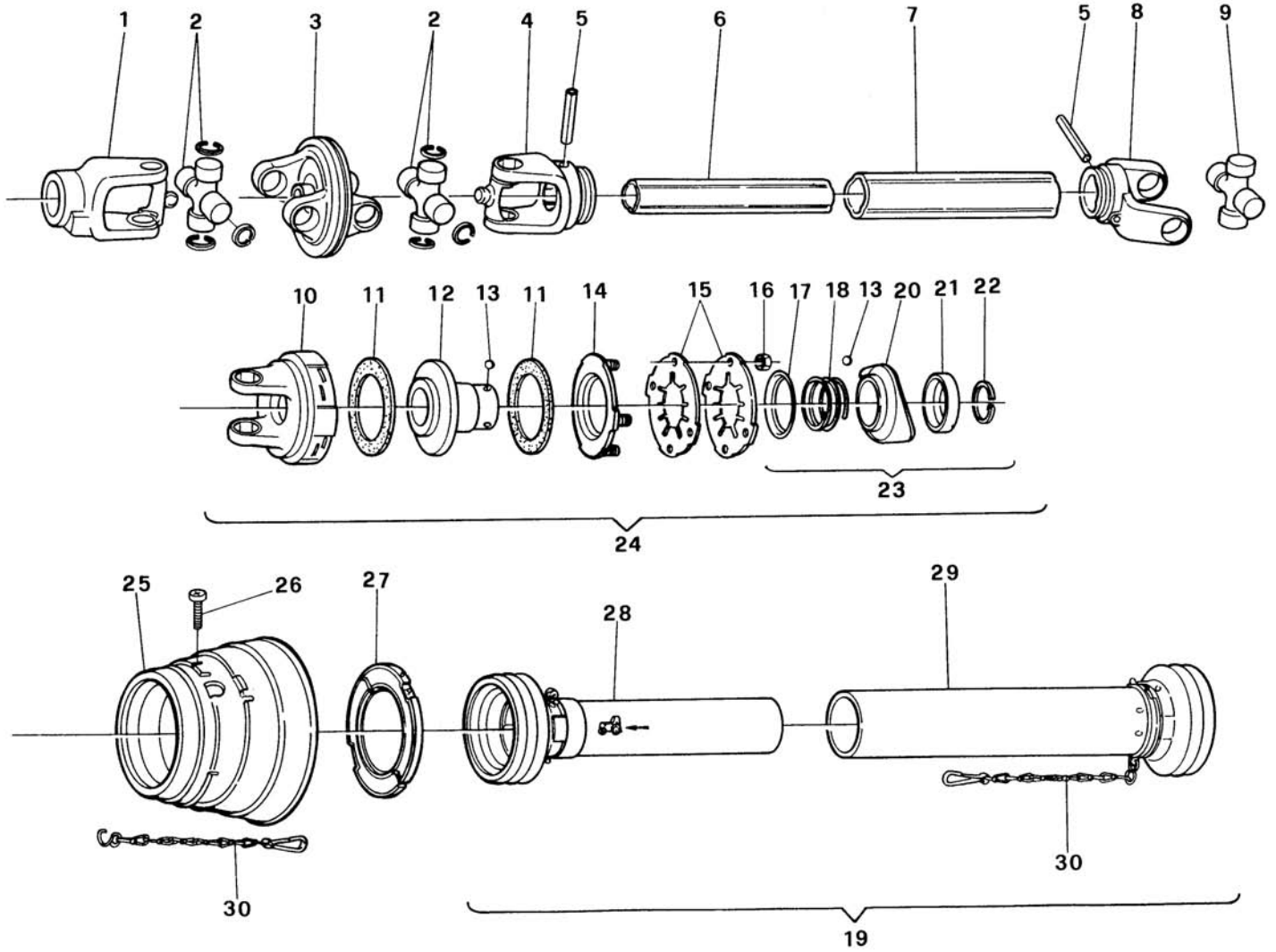

Ref.	Part #	Description	Qty.
1	366838W	PTO yoke WWE 2380	1
2	382701W	Cross & bearing WWE 2380	2
3	384517W	Double yoke WWE 2380	1
4	366862W	Yoke WWE 2380	1
5	020616W	Roll pin WWE 2380	2
6	046753W	Inner tube WWE 2380	1
7	054602W	Outer tube WWE 2380	1
8	041577W	Yoke WWE 2380	1
9	044444W	Cross & bearing WWE 2380	1
10	185836W	Clutch housing WWE 2380	1
11	168556W	Friction disc	2
12	051551W	Rotor	1
13	020692W	Lock roller	6
14	381495W	Thrust plate	1
15	043489W	Disc spring	2
16	381957W	Nut	4
17	047825W	Back up ring	1
18	045793W	Spring	1
19	106724W	Shield, complete	1
20	045790W	Bushing	1
21	338531W	Back up ring	1
22	304149W	Snap ring	1
23	341953W	Quick disconnecting lock	1
24	317189W	Slip clutch, complete WWE 2380	1
25	365715W	Protection WWE 2380	1
26	365305W	Bolt	6
27	365717W	Bearing ring WWE 2380	1
28	185530W	Protection, outer WWE 2380	1
29	368508W	Protection, inner	1
30	044321W	Chain, anti-rotation	2
	050-0040	Main driveline WWE 2380, complete	-
	950-463B	Decal "DANGER - Rotating driveline, keep away" outer shield	1
	950-464B	Decal "DANGER - Guard missing, do not operate" outer tube	1

Use only original spare parts

All rights reserved. It is unlawful to copy, reprint or use any of the information or details in this manual without the expressed written permission of the Company. Technical information provided in this manual is approximate, the Company reserves the right to modify or improve the models shown for technical or commercial purposes. Pictures in this manual do not necessarily show the machine as delivered.

BEFCO[®]

P.O. Box 6036
Rocky Mount, NC 27802-6036
Tel.: 252.977.9920 - Fax: 252.977.9718
www.befco.com

