

BEFCO®

Parts Manual

CYCLONE FLEX

**Gang Grooming Mower
312-FLX, 315-FLX, 317-FLX**

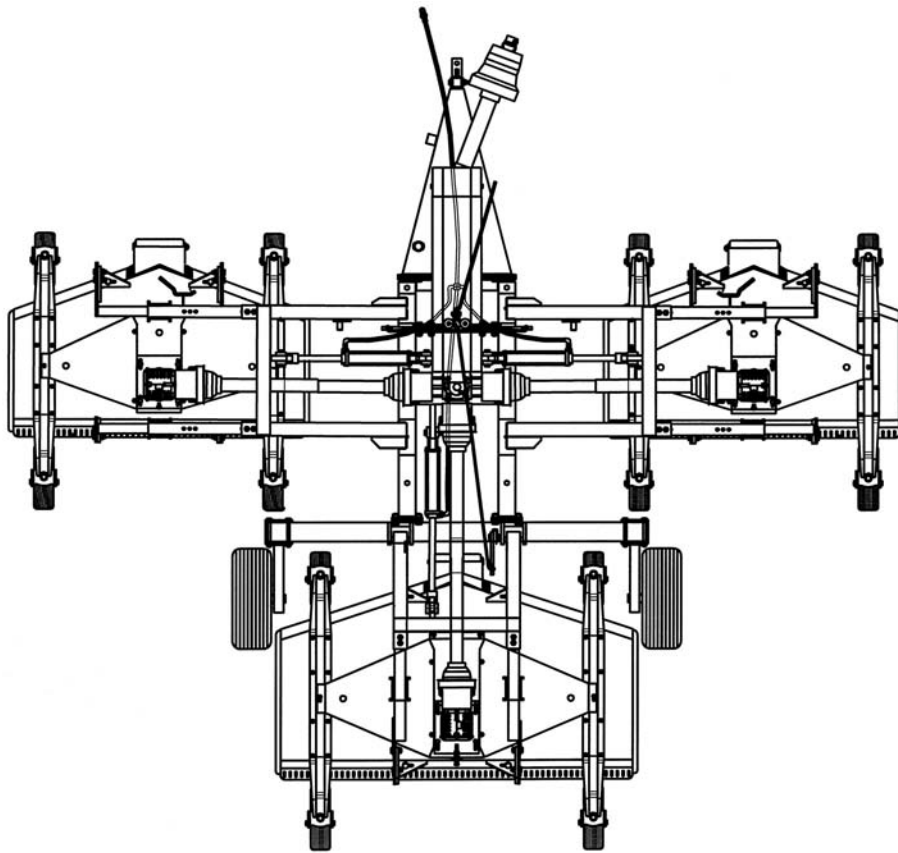

**Manual 960-207B
November 2010**

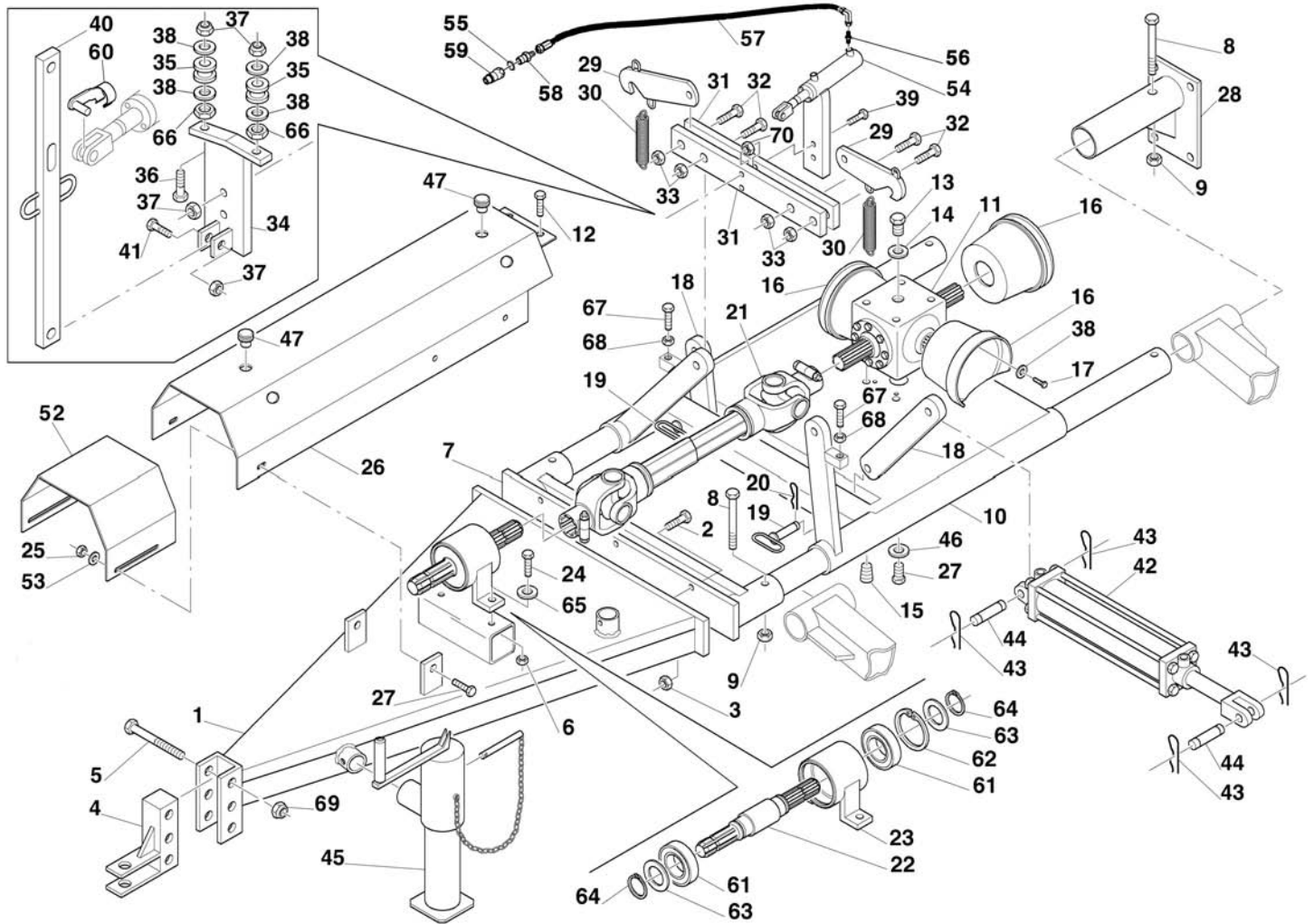

Ref.	Part #	Description	Qty.
1	005-8011	Drawbar; Ver. A & below	1
	005-8022	Drawbar; Ver. B & above	1
2	006-4377	Bolt HH M18-2.50x45 C8.8 Z F	8
3	001-7506	Nut PT M18-2.50 C6 Z TK	8
4	005-8031	Front hitch	1
	005-8050	Front floating hitch (option)	1
5	003-7368	Bolt HH M14-2.00x120 C8.8 Z P	3
6	003-0358	Nut PT M14-2.00 C6 Z TK	5
7	000-9612	Central frame hitch; Ver. A & below	1
	005-8028	Central frame hitch; Ver. B & above	1
8	000-6480	Bolt HH M14-2.00x100 C8.8 N P	4
9	000-1103	Nut HH M14-2.00 C6 N MD	4
10	005-8100	Main frame	1
11	050-0617	Gearbox, complete	1
12	006-4648	Bolt HH M12-1.75x20 C8.8 Z F	2
13	000-1107A	Breather cap	1
14	000-6691	Gasket	1
15	005-3446	Cap	1
16	000-8663	Shaft protection	3
17	000-6349	Bolt HH M10-1.50x20 C8.8 Z F	12
18	000-9173	Hitch plate	2
19	000-9201	Pin	2
20	009-1507	Hairpin cotter Ø4 Z	2
21	000-9264	Joint; Ver. G & below	2
	050-0485	PTO shaft complete, inner; Ver. H & above	1
22	000-9590	Input shaft; Ver. G & below	1
	002-7366	Input shaft; Ver. H & above	1
23	000-9223	Support input shaft SAP 207; Ver. G & below	1
	002-7360	Support input shaft; Ver. H & above	1
24	002-3265	Bolt HH M12-1.75x40 C8.8 Z F; Ver. G & below	2
	000-1526	Bolt HH M14-2.00x35 C8.8 Z F; Ver. H & above	2
25	009-4139	Nut ES M12-1.75 TN Z	2
26	000-9701	Shaft protection; Ver. G & below	1
	002-8210	Shaft protection; Ver. H & above	1
27	001-5255	Bolt HH M12-1.75x30 C8.8 Z F	6
28	015-8111	Rear hitch, right	1
	025-8111	Rear hitch, left	1
29	000-9721	Transport hook	3
30	005-1740	Spring	3
31	000-9711	Hook support plate; Ver. H (#269662) & below	1
	000-9712	Hook support plate; Ver. I (#269663) & above	2
32	003-3218	Bolt HH M16-2.00x55 C8.8 Z P	4
33	000-5581	Nut PT M16-2.00 C6 Z TK	4
34	000-9731	Bracket, unlocking handle	1
35	000-9476	Pulley, nylon	2
36	003-0334	Bolt HH M10-1.50x55 C8.8 Z F	2
37	003-0156	Nut PT M10-1.50 C6 TK Z	5
38	000-2034	Washer flat Ø10 W	16
39	003-2619	Bolt HH M10-1.50x65 C8.8 Z P	2
40	000-9737	Handle	1
	000-9740	Handle (optional hydraulic unlocking kit)	1

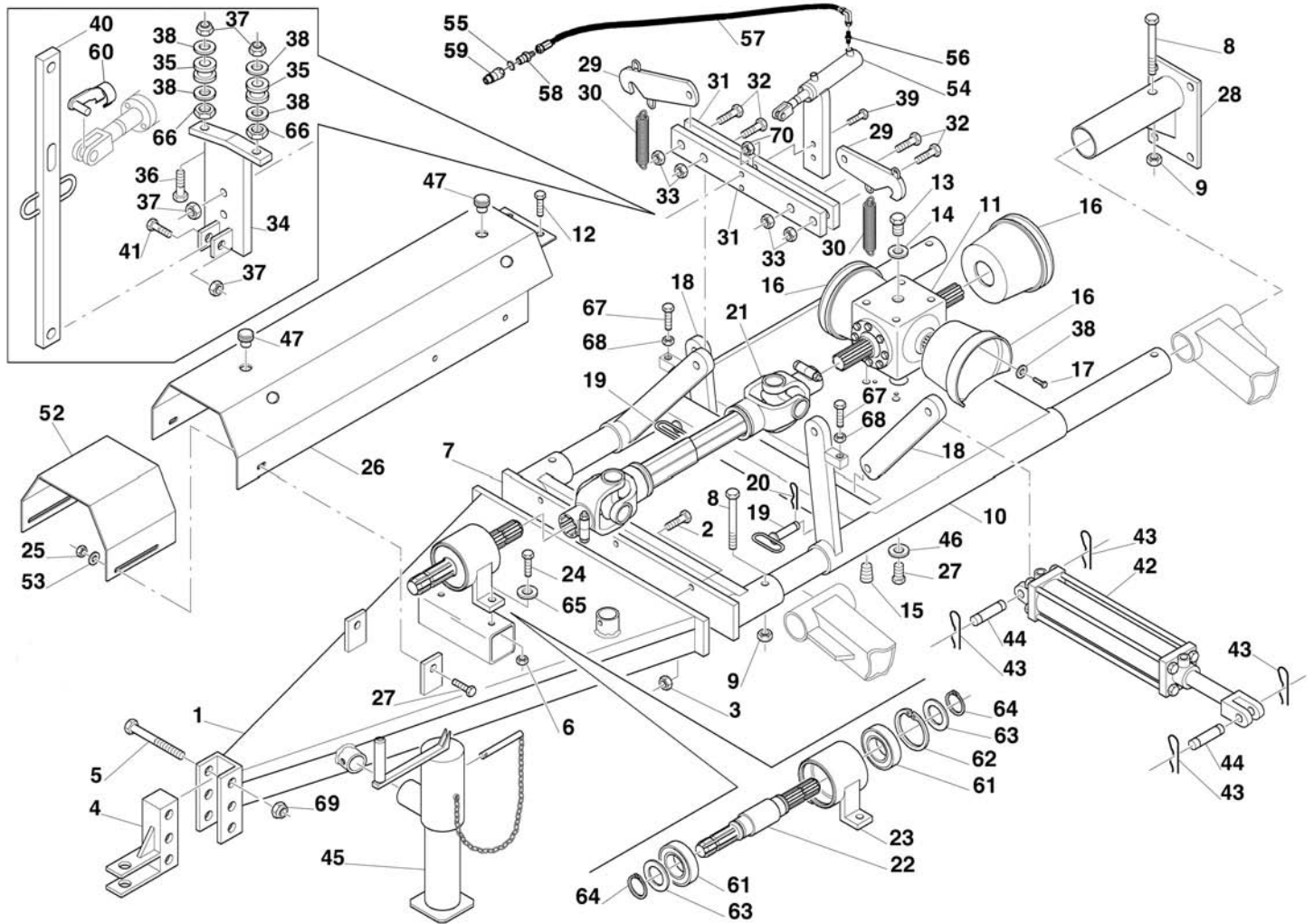

Ref.	Part #	Description	Qty.
41	003-8614	Bolt HH M10-1.50x40 C8.8 Z F	1
42	503-034B	Hydraulic cylinder	3
	502-757B	Repair kit for cylinder 503-034B	-
43	502-172B	Clip hairpin 0.105"x2.00" Z	12
44	502-171B	Pin hyd. cyl. 1.00"x3.40" Z	6
45	502-098B	Jack stand	1
46	000-1077	Washer lock Ø12 Z	4
47	000-6647	Cap	6
52	000-9702	Protection extension, input shaft	1
53	007-6106	Washer fender Ø12 Z	4
54	002-3962	Hydraulic cylinder (optional hydraulic unlocking kit)	1
55	003-6532	Washer copper 1/2" (optional hydraulic unlocking kit)	1
56	008-2484	Nipple 1/4" (optional hydraulic unlocking kit)	1
57	005-7111	Tube R1 1/4"x2300 (optional hydraulic unlocking kit)	1
58	008-2488	Nipple 1/4"-1/2" (optional hydraulic unlocking kit)	1
59	004-1871	Quick connector 1/2" (optional hydraulic unlocking kit)	1
60	002-3964	Jack fixing pin (optional hydraulic unlocking kit)	1
61	005-5358A	Bearing 6208-2RS	2
62	000-1154	Snap ring, inner Ø80	1
63	005-3248	Shim Ø40x50x2	2
64	000-8138	Snap ring, outer Ø40	2
65	009-1435	Washer flat Ø14 W	2
66	000-1279	Nut HH M10-1.50 C6 TK Z	2
67	002-3265	Bolt HH M12-1.75x40 C8.8 Z F	2
68	000-1106	Nut HH M12-1.75 C6 Z MD	2
69	000-7224	Nut ES M14-2.00 Z TK	3
70	000-2366	Nut HH M16-2.00 C6 Z TK	2
	503-854B	Light kit, complete (optional road transport kit)	1
	7900003	Rear light kit bracket, right (optional road transport kit)	1
	7900002	Rear light kit bracket, left (optional road transport kit)	1
	503-852B	Safety chain (optional road transport kit)	1
	950-352B	Sign, SMV (optional road transport kit)	1
	503-868B	Mounting bracket, SMV (optional road transport kit)	1
	001-5031	Block washer (optional road transport kit)	1
	000-6827	Spacer (optional road transport kit)	1
	008-9245	Bolt HH M14-2.00x150 C8.8 N P (optional road transport kit)	1
	960-207B	Parts Manual (312, 315, 317-FLX)	1
	961-207B	Operator's Manual (312, 315, 317-FLX)	1
	503-888B	Decal kit, safety flex mower, complete	1
	950-186B	Decal "Cyclone Flex"	1
	950-107B	Decal "BEFCO"	3
	950-298B	Decal "Cyclone"	6
	950-381B	Decal "BEFCO INC." address	1
	950-358B	Decal "Made in USA"	1
	950-235B	Decal "C50"	3
	950-311B	Decal "FX4" (312-FLX)	-
	950-312B	Decal "FX5" (312, 315-FLX)	-
	950-313B	Decal "FX6" (315, 317-FLX)	-

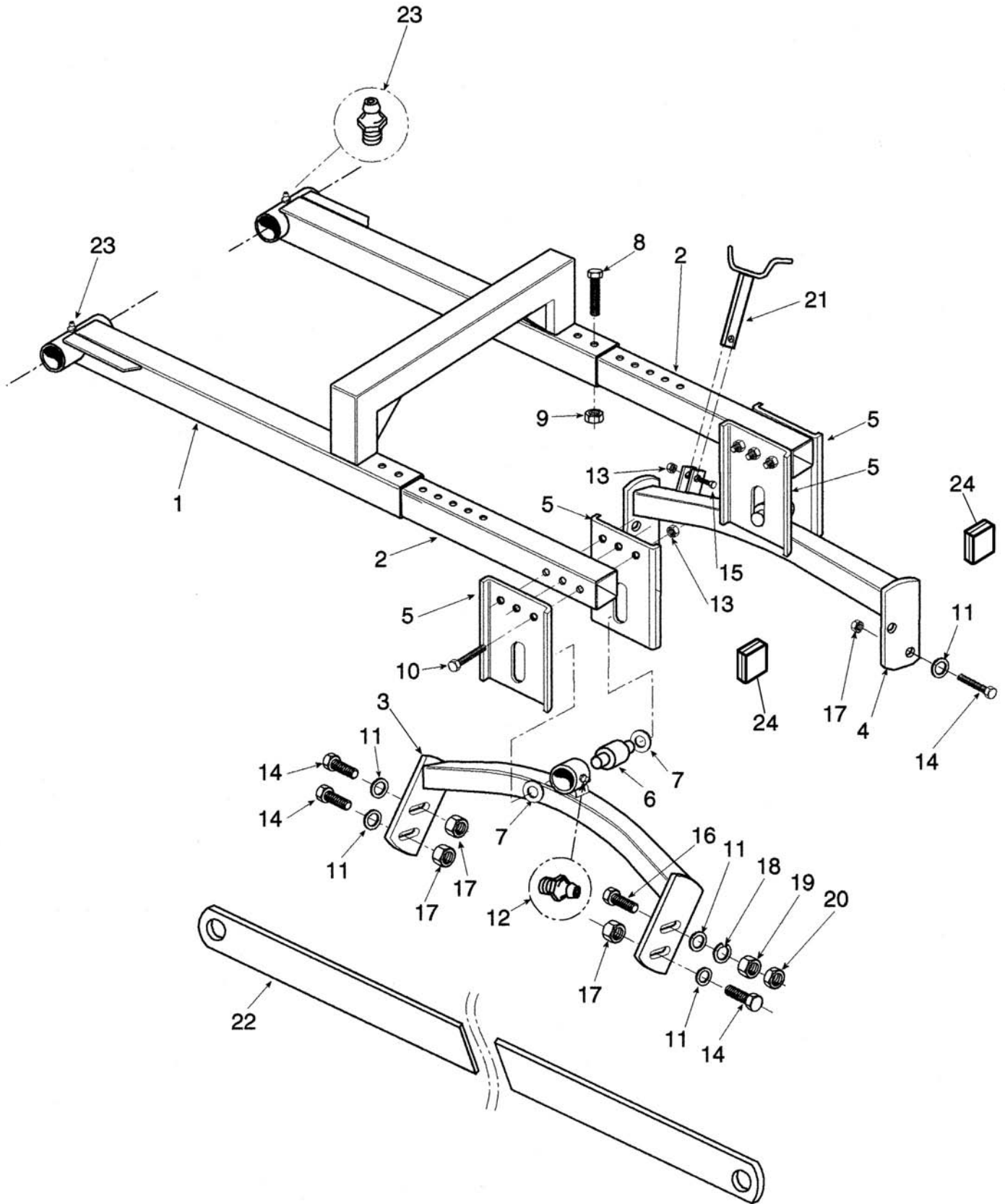

Ref.	Part #	Description	Qty.
1	025-8080	Lift side, left	1
	015-8080	Lift side, right	1
2	005-8320	Lift arm; 312, 315-FLX	4
	005-8323	Lift arm; 317-FLX	4
3	015-8340	Front hitch, right; 312-FLX	1
	025-8340	Front hitch, left; 312-FLX	1
	015-8350	Front hitch, right; 315-FLX	1
	025-8350	Front hitch, left; 315-FLX	1
	015-8360	Front hitch, right; 317-FLX	1
	025-8360	Front hitch, left; 317-FLX	1
4	015-8370	Rear hitch, right; 312-FLX	1
	025-8370	Rear hitch, left; 312-FLX	1
	035-8370	Rear hitch, right; 315, 317-FLX	1
	045-8370	Rear hitch, left; 315, 317-FLX	1
5	008-2176	Hitch plate	8
6	005-8333	Hitch pin	4
7	000-3056	Washer flat Ø30 Y	8
8	000-5536	Bolt HH M14-2.00x90 C8.8 Z P	8
9	000-7224	Nut ES M14-2.00 Z TK	8
10	003-4286	Bolt HH M12-1.75x100 C8.8 Z P	12
11	001-7354	Washer fender Ø16 Z	16
12	000-1065	Grease fitting M10-1.00	4
13	003-0064	Nut PT M12-1.75 C6 TK Z	1
14	009-1038	Bolt HH M16-2.00x50 C8.8 Z F	14
15	000-7716	Bolt HH M12-1.75x45 C8.8 Z F	1
16	003-0309	Bolt HH M16-2.00x70 C8.8 Z F	2
17	000-5581	Nut PT M16-2.00 C6 Z TK	14
18	000-2367	Washer lock Ø16 Z	2
19	000-2366	Nut HH M16-2.00 C6 Z TK	2
20	000-3124	Nut HH M16-2.00 C6 Z MD	2
21	005-8282	Kick-out bracket	2
22	015-8442	Safety tie rod; 312-FLX	1
	025-8442	Safety tie rod; 315-FLX	1
	035-8442	Safety tie rod; 317-FLX	1
23	000-6635	Grease fitting Ø6	4
24	005-8330	Plastic cap 60 mm.	4

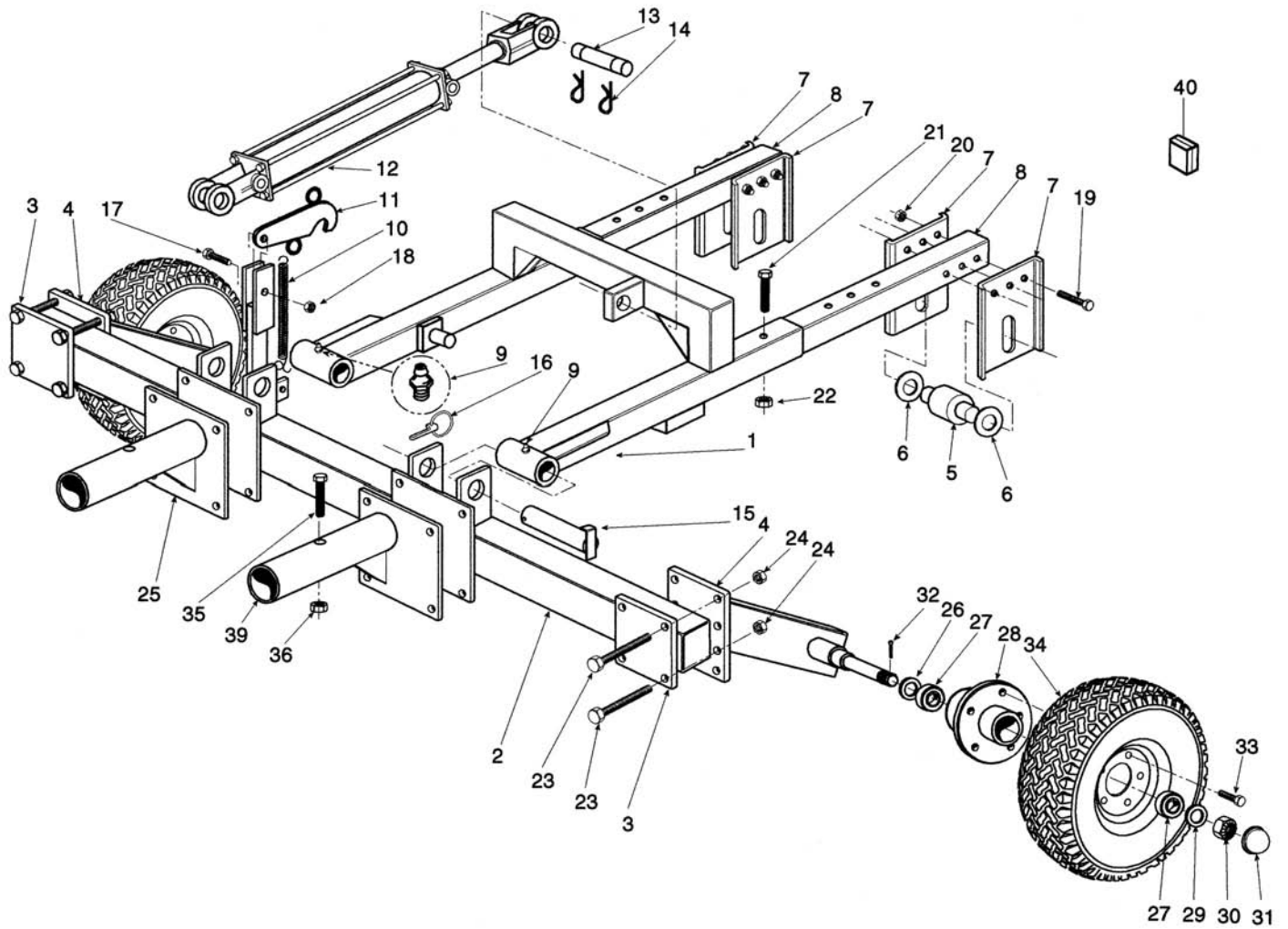

Ref.	Part #	Description	Qty.
1	005-8290	Lift, rear	1
2	005-8130	Frame, rear	1
3	000-9777	Back plate	2
4	015-8230	Wheel support, right	1
	025-8230	Wheel support, left	1
5	005-8333	Hitch pin	2
6	000-3056	Washer flat Ø30 Y	4
7	008-2176	Hitch plate	4
8	005-8326	Lift arm, rear	2
9	000-1065	Grease fitting M10-1.00	4
10	005-1740	Spring	1
11	000-9721	Transport hook	1
12	503-034B	Hydraulic cylinder	1
	502-757B	Repair kit for cylinder 503-034B	-
13	502-171B	Pin hydraulic cylinder 1.00"x3.40" Z	2
14	502-172B	Clip hairpin 0.105"x2.00" Z	1
15	005-8312	Pin, rear lift	2
16	001-8266	Lynch pin Ø11x45	2
17	005-1965	Bolt HH M16-2.00x65 C8.8 Z P	1
18	000-5581	Nut PT M16-2.00 C6 Z TK	1
19	003-4286	Bolt HH M12-1.75x100 C8.8 Z P	6
20	003-0064	Nut PT M12-1.75 C6 TK Z	6
21	000-5536	Bolt HH M14-2.00x90 C8.8 Z P	2
22	000-7224	Nut ES M14-2.00 Z TK	2
23	000-6615	Bolt HH M14-2.00x140 C8.8 Z P	8
24	003-0358	Nut PT M14-2.00 C6 Z TK	2
25	015-8111	Rear hitch, right	1
26	502-097B	Oil seal 12192TB	2
27	502-102B	Bearing L44649	4
28	502-422B	Hub wheel	2
29	004-6555	Washer flat Ø20 Z	2
30	000-9768	Nut CA M20-2.50 C5 N TN	2
31	170-8008	Bearing buddy	2
	170-8009	Bra, bearing buddy (not shown)	2
32	004-4156	Cotter pin Ø4x25	2
33	503-486B	Bolt LUG 1/2"-20x1.50" G5 Z	10
34	190-2063	Wheel, complete	2
35	000-6480	Bolt HH M14-2.00x100 C8.8 N P	2
36	000-1103	Nut HH M14-2.00 C6 N MD	2
37	006-4377	Bolt HH M18-2.50x45 C8.8 Z F	8
38	001-7506	Nut PT M18-2.50 C6 Z TK	8
39	025-8111	Rear hitch, left	1
40	005-8330	Plastic cap 60 mm.	2

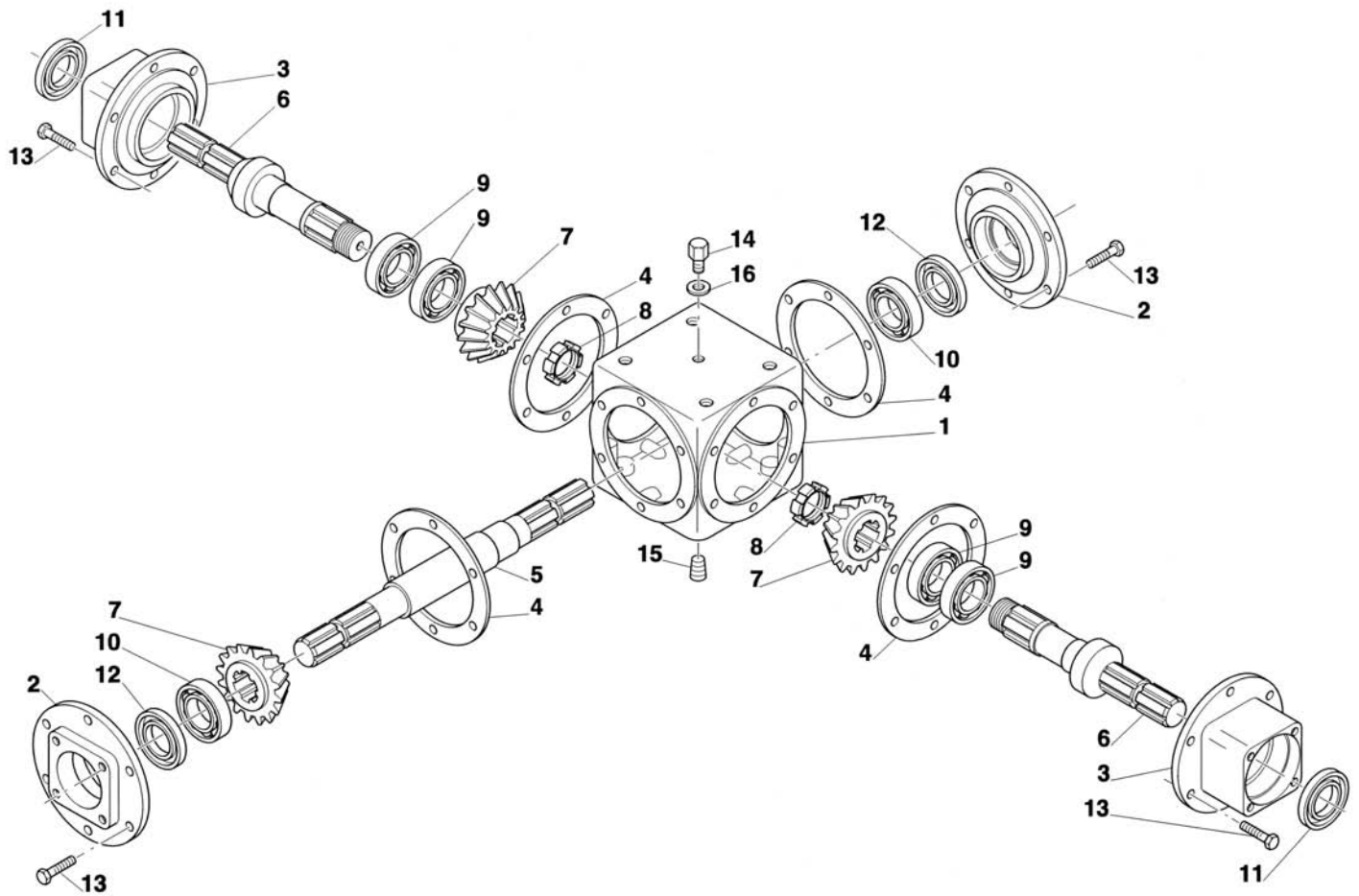

Ref.	Part #	Description	Qty.
1	000-9970	Housing, gearbox	1
2	000-9971	Front cover, gearbox housing	2
3	000-9972	Lateral support, gearbox housing	2
4	003-0193	Gasket 2/10	-
	013-0193	Gasket 5/10	-
5	000-9975	Input shaft	1
6	000-9976	Output shaft	2
7	000-9973	Ring gear	3
8	003-7098	Locking ring ES GUK M35-1.50	2
9	003-0201	Bearing 30208	4
10	000-7172A	Bearing 30207	2
11	000-7094	Oil seal 52.85.10	2
12	000-9974	Oil seal 35.55.10	2
13	000-1241	Bolt HH M10-1.50x25 C8.8 N F	24
14	000-1107A	Breather cap	1
15	005-3446	Drain plug	1
16	000-6691	Gasket	1
	050-0617	Main gearbox, complete	-

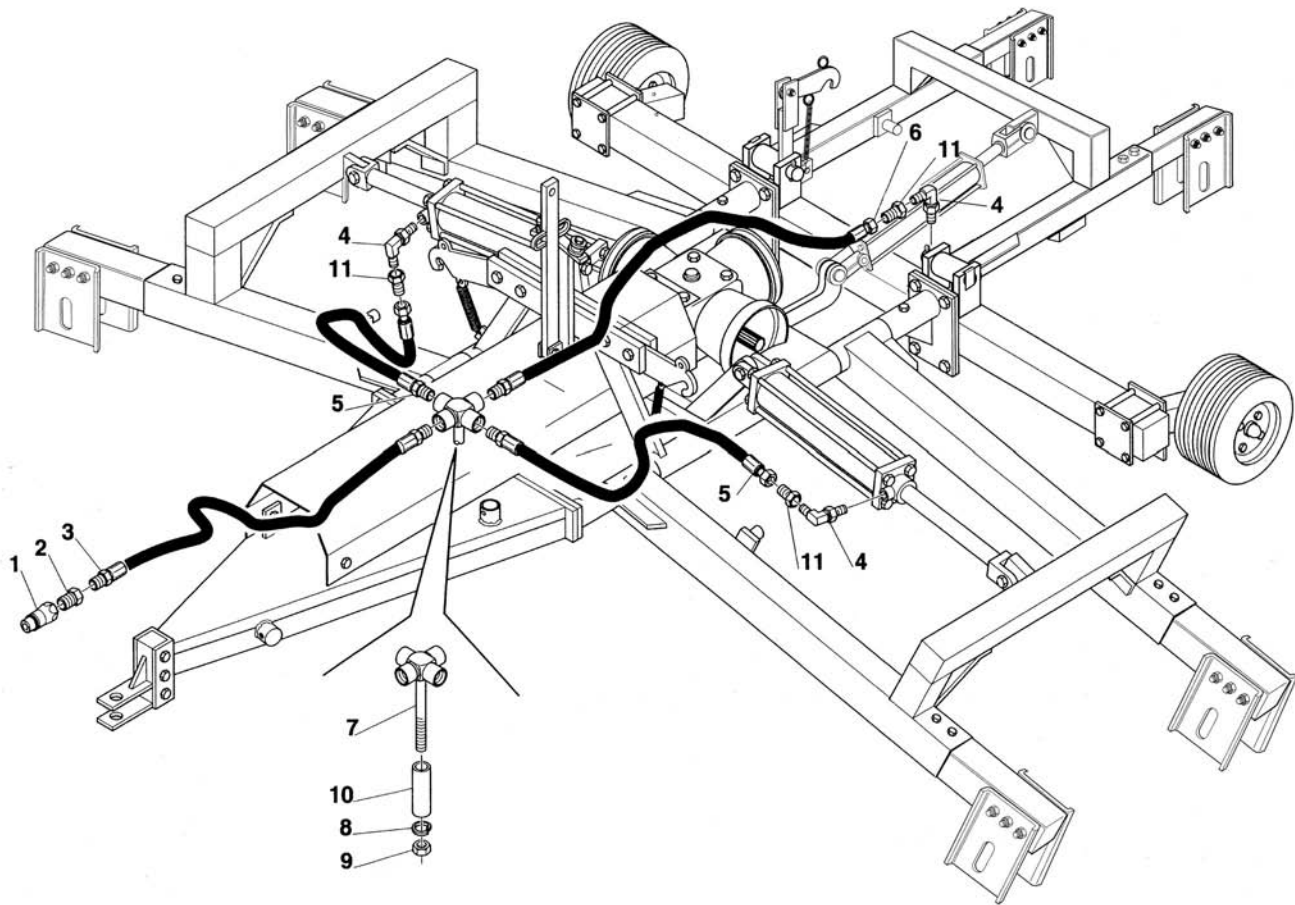

Ref.	Part #	Description	Qty.
1	502-170B	1/2" quick connect nipple 1/2" FP	1
2	502-169B	Reducer 3/8"-1/2"	1
3	502-166B	Hydraulic hose 87", front	1
4	502-163B	90° OR fitting	3
5	502-168B	Hydraulic hose 39", side	2
6	502-167B	Hydraulic hose 60", rear	1
7	502-165B	Hyd. cross 3/8" MNPT	1
8	000-1077	Washer lock Ø12 Z	1
9	000-3038	Nut HH M12-1.75 C6 Z TK	1
10	002-1285	Spacer	1
11	502-164B	Adaptor 3/8" NPT with 1/16" restrictor	3

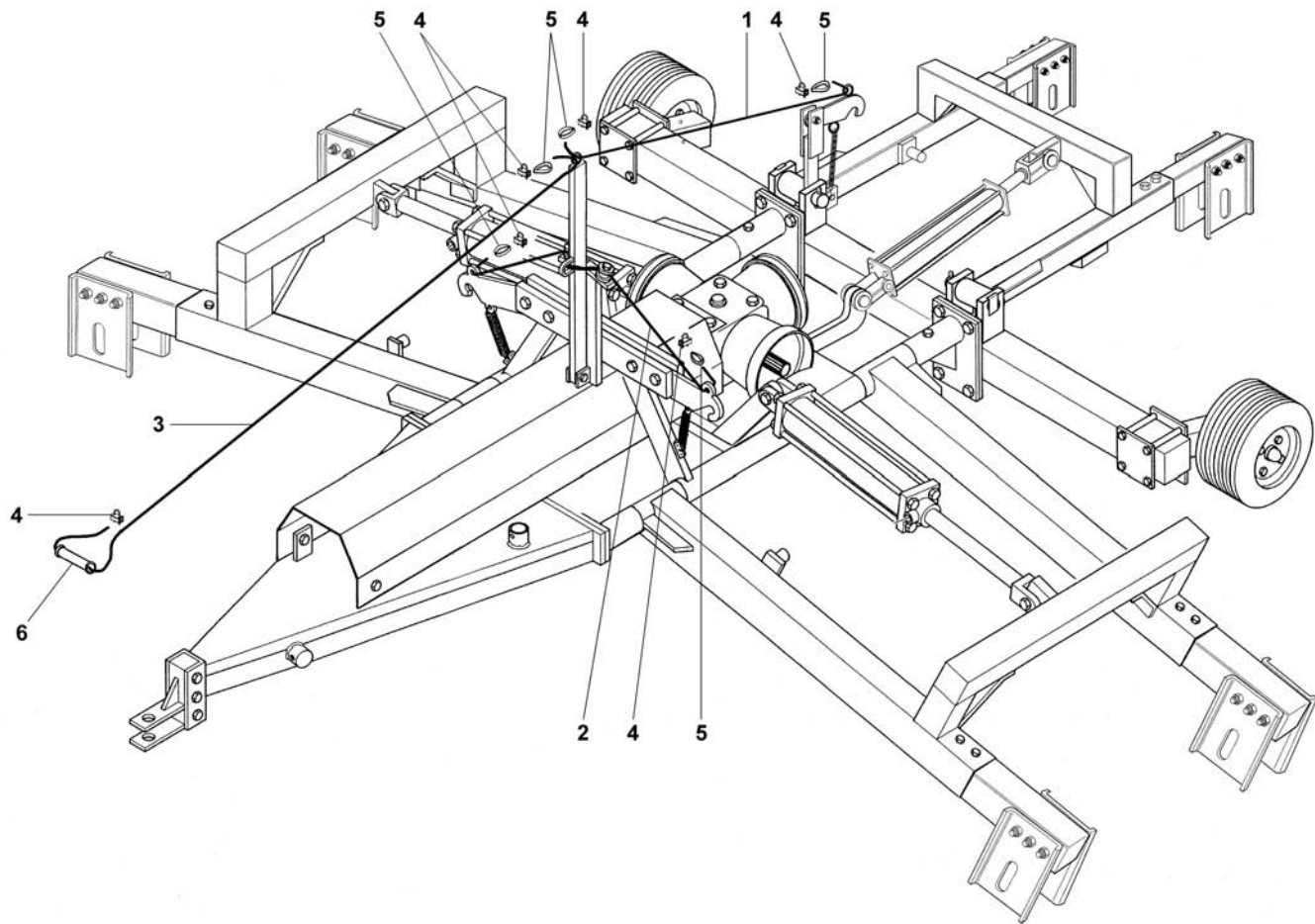

Ref.	Part #	Description	Qty.
1	005-8220	Wire rope, rear	1
2	005-8221	Wire rope, side	1
3	005-8222	Wire rope, front	1
4	005-8224	"U" clamp, complete	6
5	005-8225	Wire loop	5
6	005-8228	Handle	1

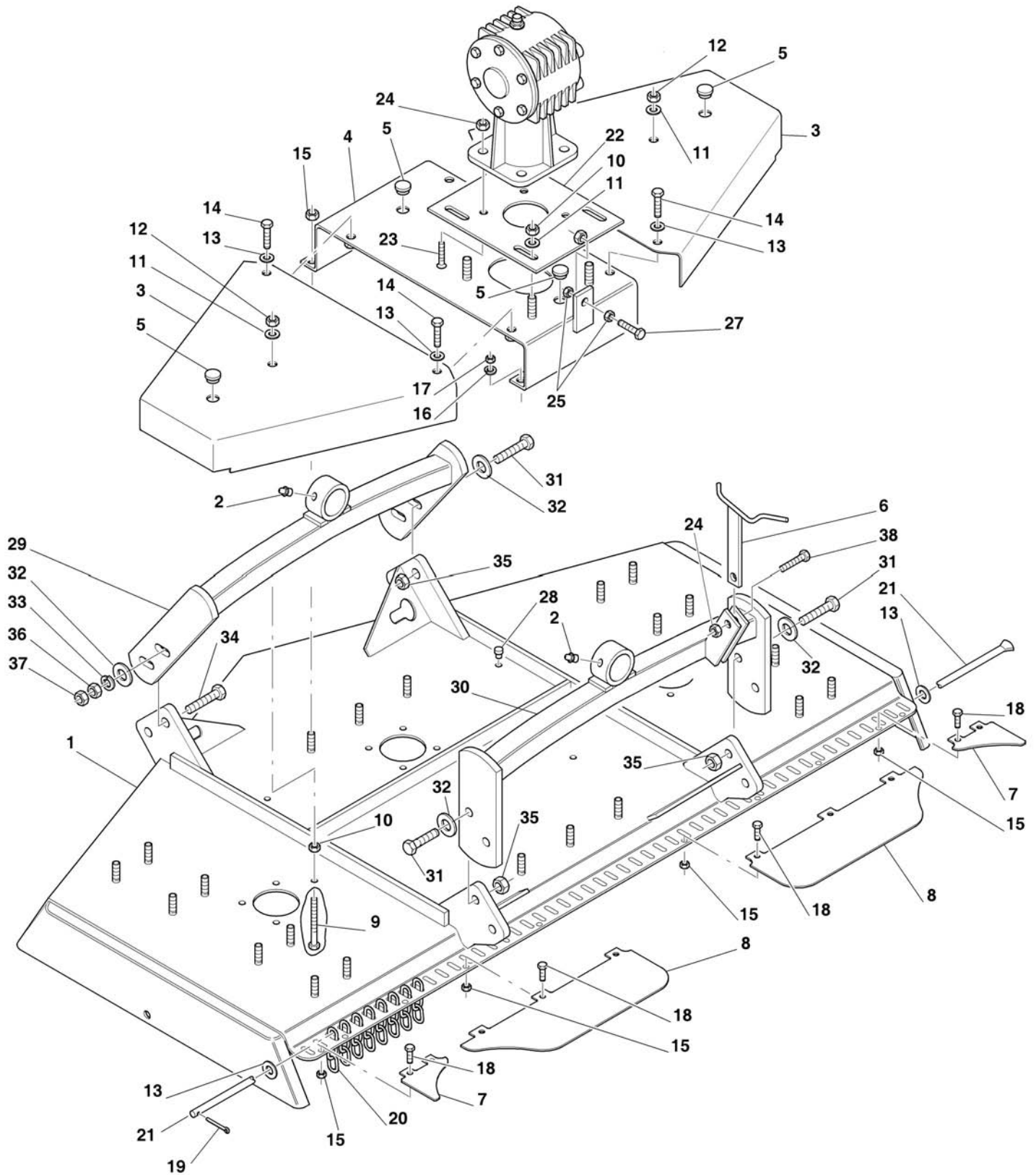

Ref.	Part #	Description	Qty.
1	010-6903	Frame 4' rear discharge; 312-FLX	2
	020-6903	Frame 5' rear discharge; 315-FLX	2
	030-6900	Frame 6' rear discharge; 317-FLX	2
2	000-1065	Grease fitting M10-1.00	4
3	010-6987	Belt shield 4' w/tab; 312-FLX First version only	4
	010-6989	Belt shield 4' w/o tab; 312-FLX Ver. A & above	4
	020-6987	Belt shield 5' w/tab; 315-FLX First version only	4
	020-6989	Belt shield 5' w/o tab; 315-FLX Ver. A & above	4
	030-6975	Belt shield 6' w/tab; 317-FLX First version only	4
	030-6989	Belt shield 6' w/o tab; 317-FLX Ver. A & above	4
4	000-6904	Central plate 4' frame; 312-FLX	2
	000-6875	Central plate 5' frame; 315-FLX	2
	000-6913	Central plate 6' frame; 317-FLX	2
5	000-6647	Cap	8
6	005-8282	Kick-out bracket	2
7	002-0411	Rear protection 5' frame, outer; 315-FLX	4
	002-0412	Rear protection 6' frame, outer; 317-FLX	4
8	002-0415	Rear protection, inner	4
9	000-6943	Bolt HH M10-1.50x120 C8.8 Z F; Ver. A & above	4
10	001-4106	Nut ES M10-1.50 Z TK	12
11	003-0157	Washer fender Ø10 Z	12
12	001-5237	Nut ES M10-1.50 Z TN	4
13	000-2034	Washer flat Ø10 W	20
14	003-3176	Bolt HH M10-1.50x25 C8.8 Z F	8
15	003-0156	Nut PT M10-1.50 C6 TK Z	-
16	000-1280	Washer lock Ø10 Z	6
17	000-1279	Nut HH M10-1.50 C6 TK Z	6
18	000-6349	Bolt HH M10-1.50x20 C8.8 Z F	-
19	004-4156	Cotter pin Ø4x25	2
20	000-6764	Chain links; 312-FLX	82
	000-6764	Chain links; 315-FLX	100
	000-6764	Chain links; 317-FLX	122
21	010-6762	Chain rod 4' frame; 312-FLX	2
	020-6762	Chain rod 5' frame; 315-FLX	2
	030-6762	Chain rod 6' frame; 317-FLX	2
22	000-6541	Support plate, gearbox	2
23	007-4183	Bolt CS M12-1.75x40 C10.9 Z F	8
24	003-0064	Nut PT M12-1.75 C6 TK Z	10
25	000-1106	Nut HH M12-1.75 C6 Z MD	4
26	000-8663	Shaft protection	2
27	000-6547	Bolt HH M12-1.75x100 C8.8 Z F	2
28	005-1570	Cap	8
29	015-8340	Front hitch 4' right frame; 312-FLX	1
	025-8340	Front hitch 4' left frame; 312-FLX	1
	015-8350	Front hitch 5' right frame; 315-FLX	1
	025-8350	Front hitch 5' left frame; 315-FLX	1
	015-8360	Front hitch 6' right frame; 317-FLX	1
	025-8360	Front hitch 6' left frame; 317-FLX	1

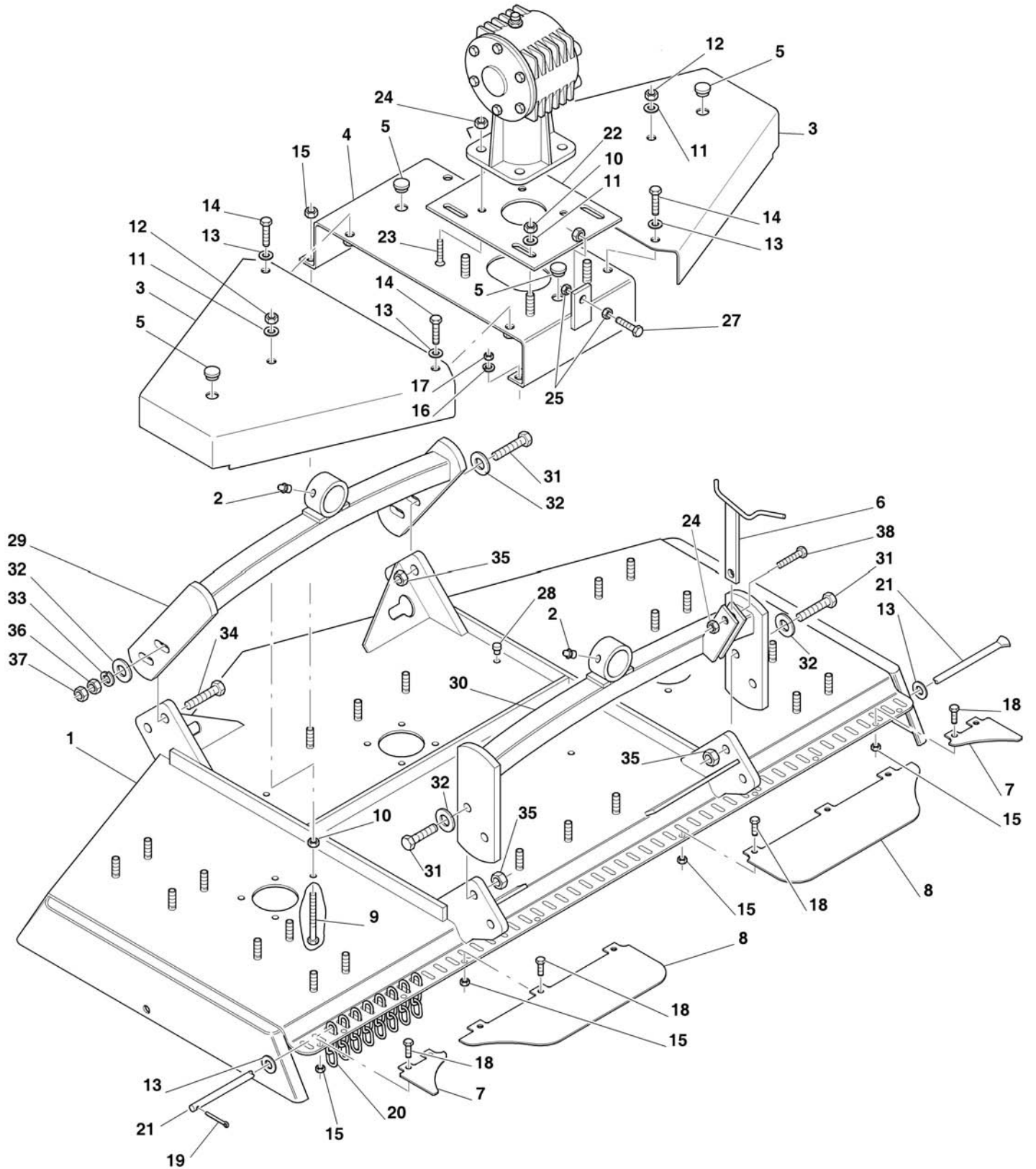

Ref.	Part #	Description	Qty.
30	015-8370	Rear hitch 4' right frame; 312-FLX	1
	025-8370	Rear hitch 4' left frame; 312-FLX	1
	035-8370	Rear hitch 5' & 6' right frame; 315, 317-FLX	1
	045-8370	Rear hitch 5' & 6' left frame; 315, 317-FLX	1
31	009-1038	Bolt HH M16-2.00x50 C8.8 Z F	14
32	001-7354	Washer fender Ø16 Z	16
33	000-2367	Washer lock Ø16 Z	2
34	003-0309	Bolt HH M16-2.00x70 C8.8 Z F	2
35	000-5581	Nut PT M16-2.00 C6 Z TK	14
36	000-2366	Nut HH M16-2.00 C6 Z TK	2
37	000-3124	Nut HH M16-2.00 C6 Z MD	2
38	000-7716	Bolt HH M12-1.75x45 C8.8 Z F	2

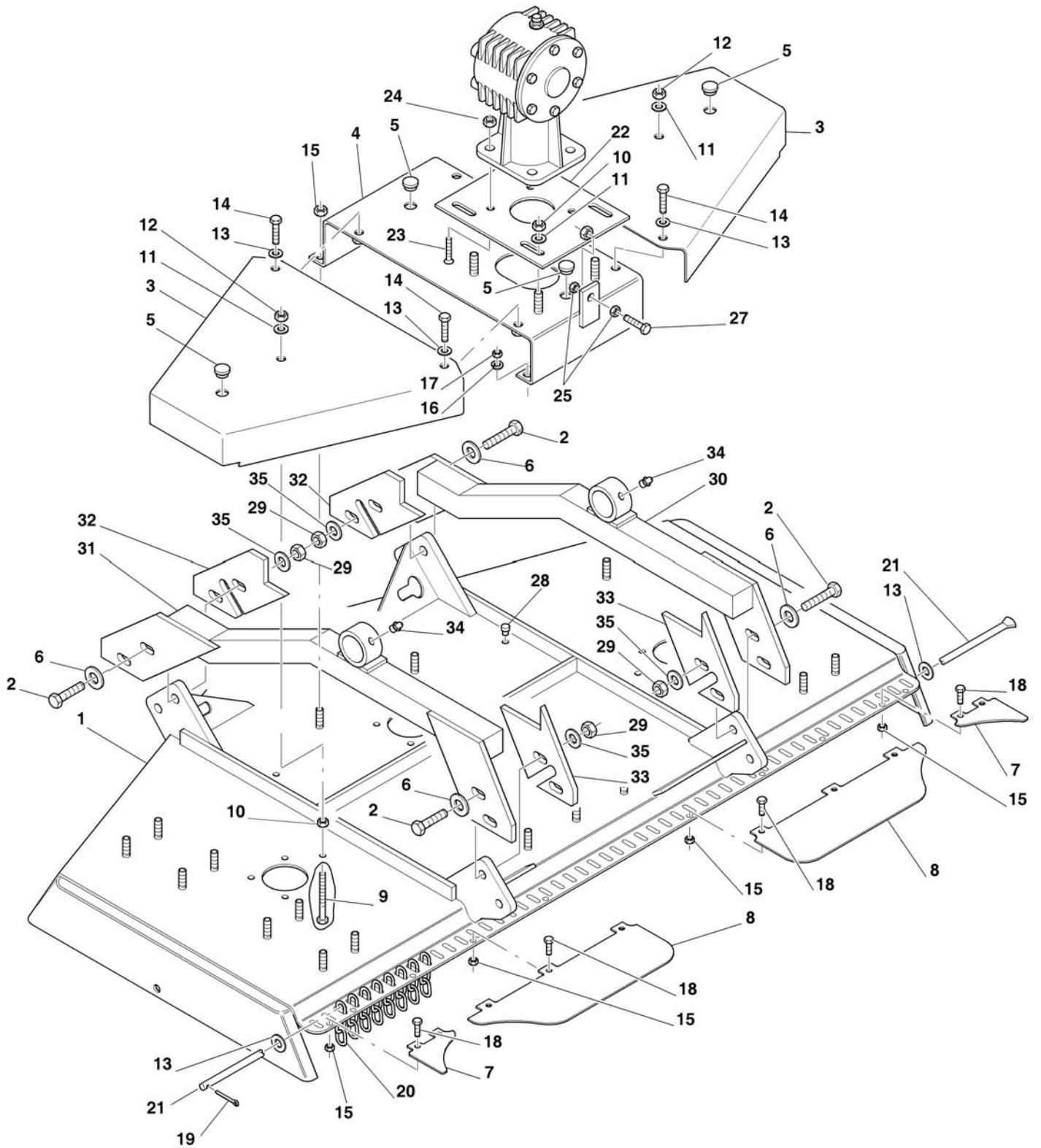

Ref.	Part #	Description	Qty.
1	020-6903	Frame 5' rear discharge; 312-FLX	1
	030-6900	Frame 6' rear discharge; 315, 317-FLX	1
2	005-1965	Bolt HH M16-2.00x65 C8.8 Z P	8
3	020-6987	Belt shield 5' w/tab; 312-FLX First version only	2
	020-6989	Belt shield 5' w/o tab; 312-FLX Ver. A & above	2
	030-6975	Belt shield 6' w/tab; 315 & 317-FLX First version only	2
	030-6989	Belt shield 6' w/o tab; 315, 317-FLX Ver. A & above	2
4	000-6875	Central plate 5' frame; 312-FLX	1
	000-6913	Central plate 6' frame; 315, 317-FLX	1
5	000-6647	Cap	4
6	001-7354	Washer fender Ø16 Z	8
7	002-0411	Rear protection 5' frame, outer; 312-FLX	2
	002-0412	Rear protection 6' frame, outer; 315, 317-FLX	2
8	002-0415	Rear protection, inner	2
9	000-6943	Bolt HH M10-1.50x120 C8.8 Z F; Ver. A & above	2
10	001-4106	Nut ES M10-1.50 Z TK	6
11	003-0157	Washer fender Ø10 Z	6
12	001-5237	Nut ES M10-1.50 Z TN	2
13	000-2034	Washer flat Ø10 W	10
14	003-3176	Bolt HH M10-1.50x25 C8.8 Z F	4
15	003-0156	Nut PT M10-1.50 C6 TK Z	13
16	000-1280	Washer lock Ø10 Z	3
17	000-1279	Nut HH M10-1.50 C6 TK Z	3
18	000-6349	Bolt HH M10-1.50x20 C8.8 Z F	14
19	004-4156	Cotter pin Ø4x25	1
20	000-6764	Chain links; 312-FLX	50
	000-6764	Chain links; 315, 317-FLX	61
21	020-6762	Chain rod 5' frame; 312-FLX	1
	030-6762	Chain rod 6' frame; 315, 317-FLX	1
22	000-6541	Support plate, gearbox	1
23	007-4183	Bolt CS M12-1.75x40 C10.9 Z F	4
24	003-0064	Nut PT M12-1.75 C6 TK Z	4
25	000-1106	Nut HH M12-1.75 C6 Z MD	2
26	000-8663	Shaft protection	1
27	000-6547	Bolt HH M12-1.75x100 C8.8 Z F	1
28	005-1570	Cap	4
29	000-5581	Nut PT M16-2.00 C6 Z TK	8
30	015-8400	Right hitch 5' rear frame; 312-FLX	1
	015-8430	Right hitch 6' rear frame; 315, 317-FLX	1
31	025-8400	Left hitch 5' rear frame; 312-FLX	1
	025-8430	Left hitch 6' rear frame; 315, 317-FLX	1
32	005-8418	Short plate	2
33	005-8419	Long plate	2
34	000-1065	Grease fitting M10-1.00	2
35	000-8568	Washer flat Ø16 W	8

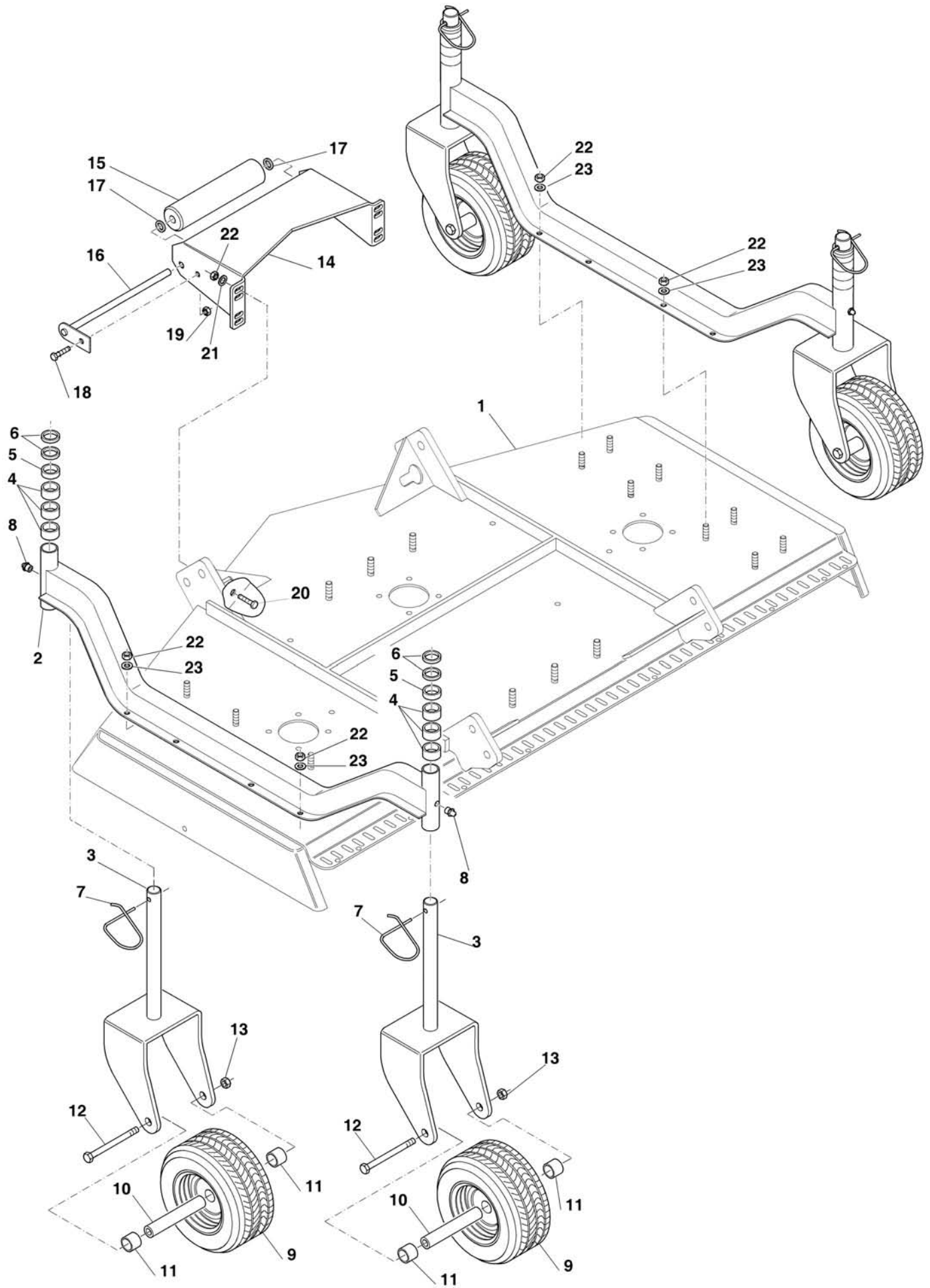

Ref.	Part #	Description	Qty.
1	010-6903	Frame 4' rear discharge; 312-FLX	2
	020-6903	Frame 5' rear discharge; 315-FLX	2
	030-6900	Frame 6' rear discharge; 317-FLX	2
2	010-6939	Wheel arm 4' frame w/center hole; 312-FLX First version only	4
	010-6941	Wheel arm 4' frame w/o center hole; 312-FLX Ver. A & above	4
	020-6939	Wheel arm 5' frame w/center hole; 315-FLX First version only	4
	020-6941	Wheel arm 5' frame w/o center hole; 315-FLX Ver. A & above	4
	030-6932	Wheel arm 6' frame w/center hole; 317-FLX First version only	4
	030-6941	Wheel arm 6' frame w/o center hole; 317-FLX Ver. A & above	4
3	000-6946	Wheel yoke	8
4	000-6586	Spacer, height adjustment 1"	24
5	000-6587	Spacer, height adjustment ½"	8
6	000-6589	Spacer, height adjustment ¼"	16
7	000-8783	Pin SP, wheel yoke	8
8	000-1065	Grease fitting M10-1.00	8
9	000-6923Y	Wheel hard tire, complete	8
	503-723B	Bearing 6204-Z, hard tire (not shown)	16
	000-6967	Wheel 11" air tire, complete ¹ ; #270186 & below	8
	000-6969A	Steel retainer, air tire; #270186 & below (not shown)	16
	000-6968	Bearing needle, air tire; #270186 & below (not shown)	16
	000-6964	Wheel 11" air tire, complete; #270187 & above	8
	005-0142	Bearing 6204-2RS, air tire; #270187 & above (not shown)	16
	000-6962	Dust cover, air tire; #270187 & above (not shown)	16
10	000-6584	Inner wheel spacer	8
11	000-6585	Outer wheel spacer, hard tire	16
	000-6972	Outer wheel spacer, 11" air tire; #270187 & above	16
12	000-6619	Bolt HH M14-2.00x150 C8.8 Z P	8
13	003-0358	Nut PT M14-2.00 C6 Z TK	8
14	000-9622	Support, front roller; Ver. I (#269662) & below	2
	006-7354	Support, front roller; Ver. L (#269663) & above	1
15	006-7358	Front roller Ø3"	2
16	006-7363	Roller pin; Ver. I (#269662) & below	2
	006-7365	Roller pin; Ver. L (#269663) & above	2
17	000-8568	Washer flat Ø16 W	4
18	004-6454	Bolt HH M08-1.25x16 C8.8 Z F	2
19	001-1328	Nut PT M08-1.25 C6 Z TK	2
20	000-6349	Bolt HH M10-1.50x20 C8.8 Z F	8
21	000-2034	Washer flat Ø10 W	8
22	003-0156	Nut PT M10-1.50 C6 TK Z	40
23	003-0157	Washer fender Ø10 Z	32

¹ Wheel no longer available, part #000-6964 should be ordered instead. Serial #270186 and below must also order two (2) outer wheel spacers (000-6972) when replacing wheel.

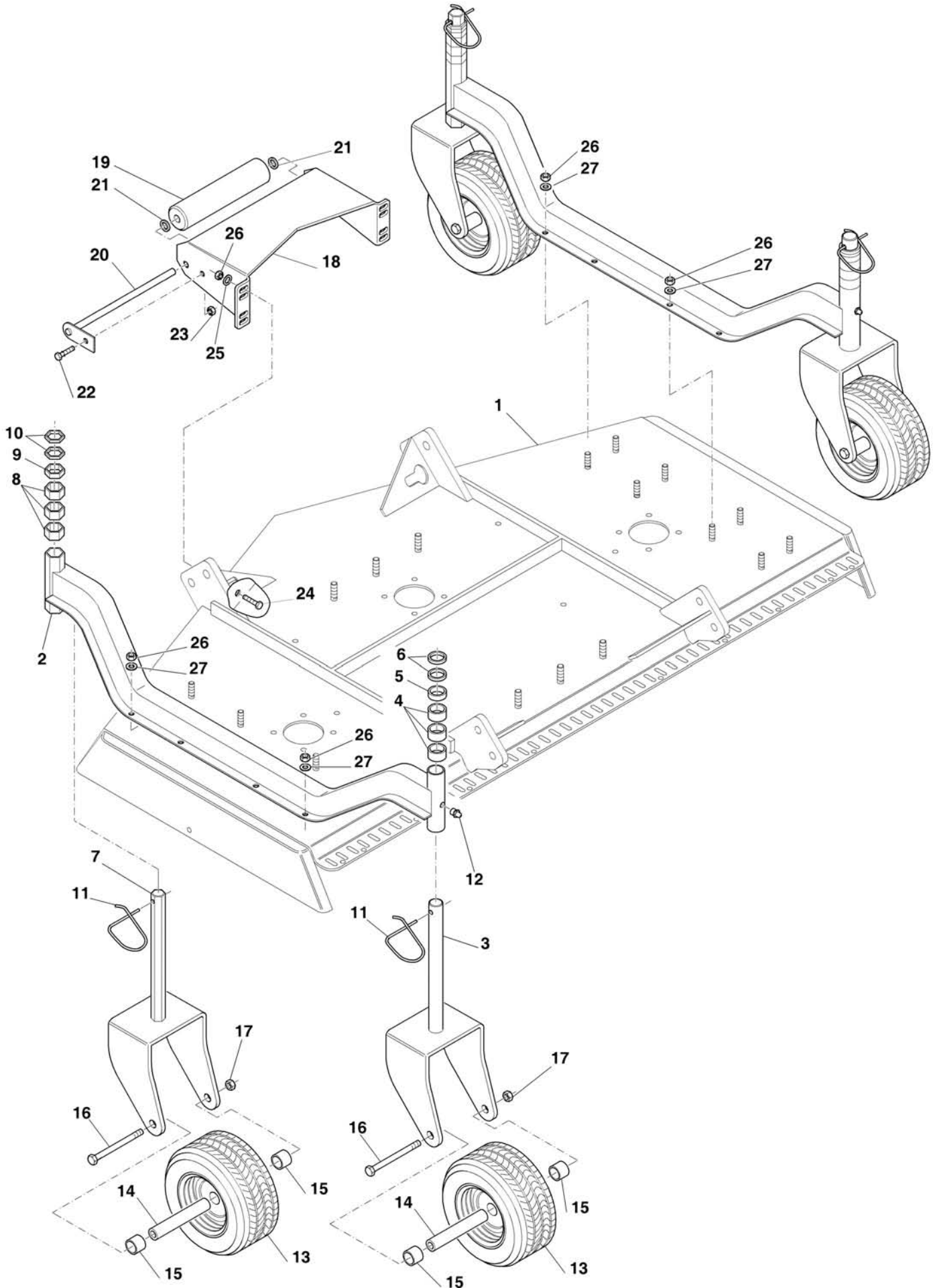

Ref.	Part #	Description	Qty.
1	020-6903	Frame 5' rear discharge; 312-FLX	1
	030-6900	Frame 6' rear discharge; 315, 317-FLX	1
2	005-8530	Wheel arm 5' hex w/center hole; 312-FLX First version only	2
	025-8526	Wheel arm 5' hex w/o center hole; 312-FLX Ver. A & above	2
	005-8540	Wheel arm 6' hex w/center hole; 315, 317-FLX First version only	2
	035-8526	Wheel arm 6' hex w/o center hole; 315, 317-FLX Ver. A & above	2
3	000-6946	Wheel yoke, round shaft	2
4	000-6586	Spacer, height adjustment 1", round shaft	6
5	000-6587	Spacer, height adjustment ½", round shaft	2
6	000-6589	Spacer, height adjustment ¼", round shaft	4
7	005-8551	Wheel yoke, hex shaft	2
8	005-8555	Round spacer, height adjustment 1", hex shaft	6
	005-8560	Hex spacer, height adjustment 1", hex shaft	6
9	005-8556	Round spacer, height adjustment ½", hex shaft	2
	005-8561	Hex spacer, height adjustment ½", hex shaft	2
10	005-8557	Round spacer, height adjustment ¼", hex shaft	4
	005-8562	Hex spacer, height adjustment ¼", hex shaft	4
11	000-8783	Pin SP, wheel yoke	4
12	000-1065	Grease fitting M10-1.00	2
13	000-6923Y	Wheel hard tire, complete	4
	503-723B	Bearing 6204-Z, hard tire (not shown)	8
	000-6967	Wheel 11" air tire, complete ² ; #270186 & below	4
	000-6969A	Steel retainer, air tire; #270186 & below (not shown)	8
	000-6968	Bearing needle, air tire; #270186 & below (not shown)	8
	000-6964	Wheel 11" air tire, complete; #270187 & above	4
	005-0142	Bearing 6204-2RS, air tire; #270187 & above (not shown)	8
	000-6962	Dust cover, air tire; #270187 & above (not shown)	8
14	000-6584	Inner wheel spacer	4
15	000-6585	Outer wheel spacer, hard tire	8
	000-6972	Outer wheel spacer, 11" air tire; #270187 & above	8
16	000-6619	Bolt HH M14-2.00x150 C8.8 Z P	4
17	003-0358	Nut PT M14-2.00 C6 Z TK	4
18	000-9622	Support, front roller; Ver. I (#269662) & below	1
	006-7354	Support, front roller; Ver. L (#269663) & above	1
19	006-7358	Front roller Ø3"	1
20	006-7363	Roller pin; Ver. I (#269662) & below	1
	006-7365	Roller pin; Ver. L (#269663) & above	1
21	000-8568	Washer flat Ø16 W	2
22	004-6454	Bolt HH M08-1.25x16 C8.8 Z F	1
23	001-1328	Nut PT M08-1.25 C6 Z TK	1
24	000-6349	Bolt HH M10-1.50x20 C8.8 Z F	4
25	000-2034	Washer flat Ø10 W	4
26	003-0156	Nut PT M10-1.50 C6 TK Z	20
27	003-0157	Washer fender Ø10 Z	16

² Wheel no longer available, part #000-6964 should be ordered instead. Serial #270186 and below must also order two (2) outer wheel spacers (000-6972) when replacing wheel.

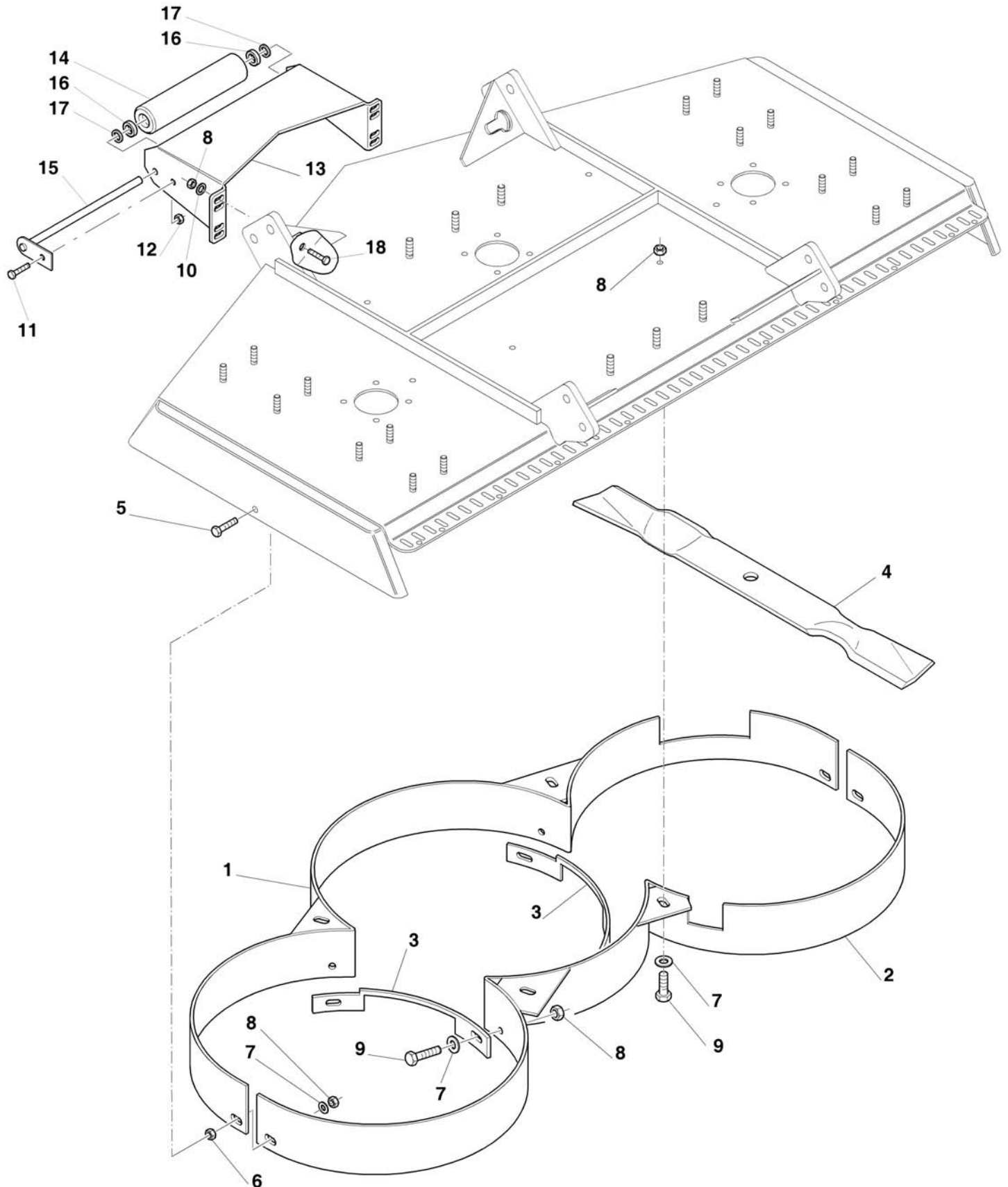

Ref.	Part #	Description	Qty.
1	000-6782	Baffling front, 4' frame	1
	000-6783	Baffling front, 5' frame	1
	000-6784	Baffling front, 6' frame	1
2	000-6776	Baffling rear, 4' frame	1
	000-6777	Baffling rear, 5' frame	1
	000-6778	Baffling rear, 6' frame	1
3	000-6780	Guard support, 6' frame	2
4	000-6795M	Blade mulching, 4' frame	3
	000-6641M	Blade mulching, 5' frame	3
	000-6845M	Blade mulching, 6' frame	3
5	009-1281	Bolt HH M10-1.50x35 C8.8 Z F	2
6	000-3038	Nut HH M12-1.75 C6 Z TK	2
7	003-0157	Washer fender Ø10 Z	-
8	003-0156	Nut PT M10-1.50 C6 TK Z	-
9	000-6349	Bolt HH M10-1.50x20 C8.8 Z F	-
10	000-2034	Washer flat Ø10 W	4
11	001-5012	Bolt HH M08-1.25x20 C8.8 Z F	1
12	001-1328	Nut PT M08-1.25 C6 Z TK	1
13	005-8500	Support, front roller (pro roller only)	1
14	005-8507	Front roller (pro roller only)	1
15	005-8504	Roller pin (pro roller only)	1
16	005-8508	Bearing 6202-2RS	2
17	005-8503	Shim Ø17x24x1.5	2
18	003-3176	Bolt HH M10-1.50x25 C8.8 Z F	4
	004-700	Mulching kit 4' frame, complete	-
	005-700	Mulching kit 5' frame, complete	-
	006-700	Mulching kit 6' frame, complete	-
	009-9556	Mulching kit, complete, 3 units; 312-FLX	-
	009-9557	Mulching kit, complete, 3 units; 315-FLX	-
	009-9558	Mulching kit, complete, 3 units; 317-FLX	-
	009-9815	Professional front roller, complete, 1 unit	-
	009-9816	Professional front roller, complete, 3 units	-

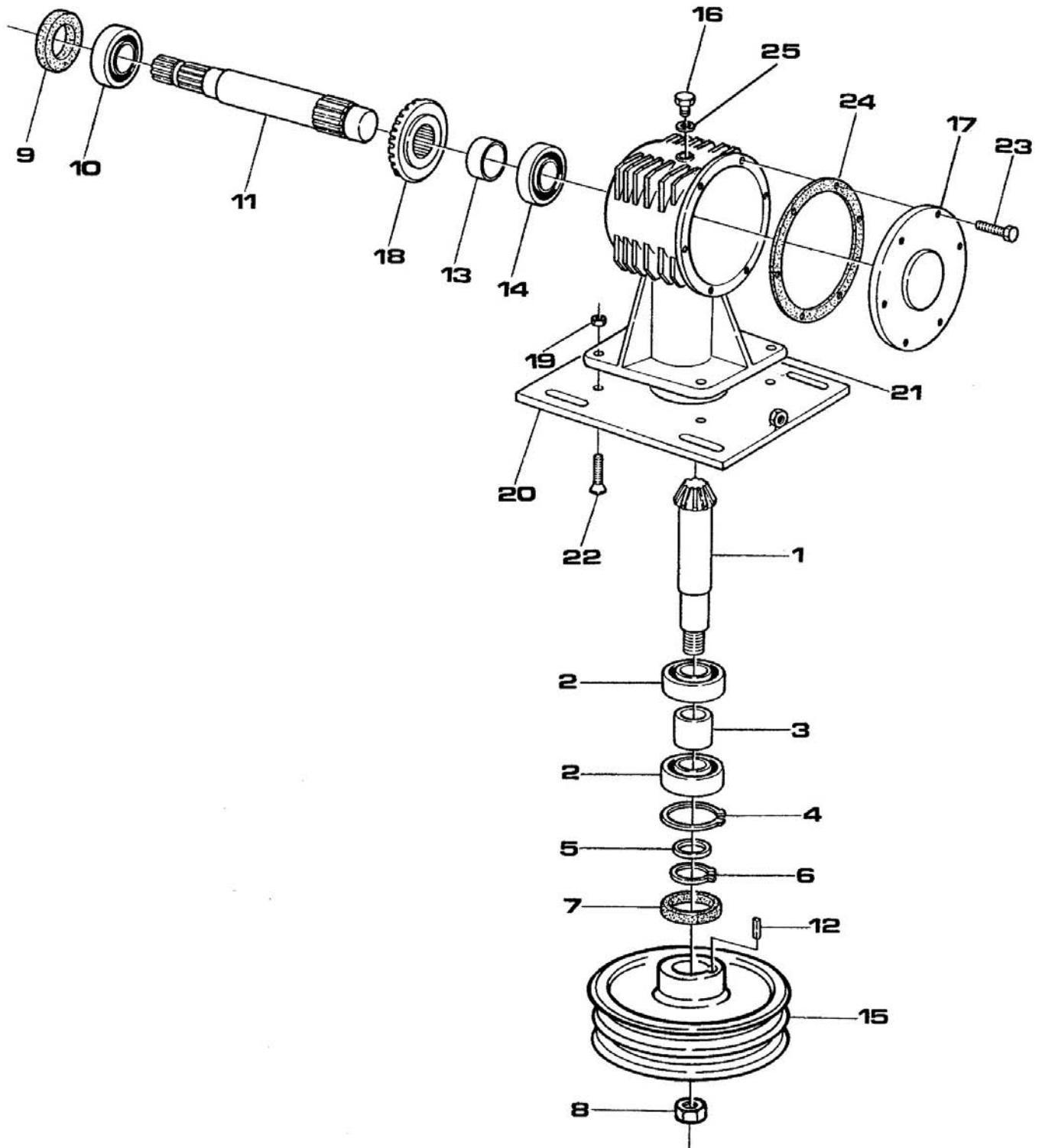

Ref.	Part #	Description	Qty.
1	005-8479	Pinion gear, helical gears	1
2	001-2149A	Bearing 6208	2
3	000-6687	Spacer	1
4	000-1154	Snap ring, inner Ø80	1
5	000-6685	Shim Ø40x50x2.5	1
6	000-8138	Snap ring, outer Ø40	1
7	000-6684	Oil seal 40.80.10	1
8	000-6698	Nut SP M25-1.50 Z	1
9	000-2295	Oil seal 35.62.10	1
10	002-5332A	Bearing 6207	1
11	005-8464	Input shaft	1
12	000-6689	Key 7x8x30	1
13	000-6661	Rear spacer (until 09/00)	1
14	005-8472A	Bearing 30206	1
15	000-6692	Pulley SPB 250x2	1
16	000-1107A	Breather cap	1
17	000-6656	Gear cover, gearbox housing	1
18	005-8477	Ring gear, helical gears	1
19	003-0064	Nut PT M12-1.75 C6 TK Z	4
20	000-6541	Support plate, gearbox	1
21	000-6658	Housing, gearbox	1
22	007-4183	Bolt CS M12-1.75x40 C10.9 Z F	4
23	000-6349	Bolt HH M10-1.50x20 C8.8 Z F	6
24	003-0193	Gasket 2/10	-
	013-0193	Gasket 5/10	-
25	000-6691	Gasket, aluminum	1
	050-0642	Gearbox 540 rpm helical gears, complete	-

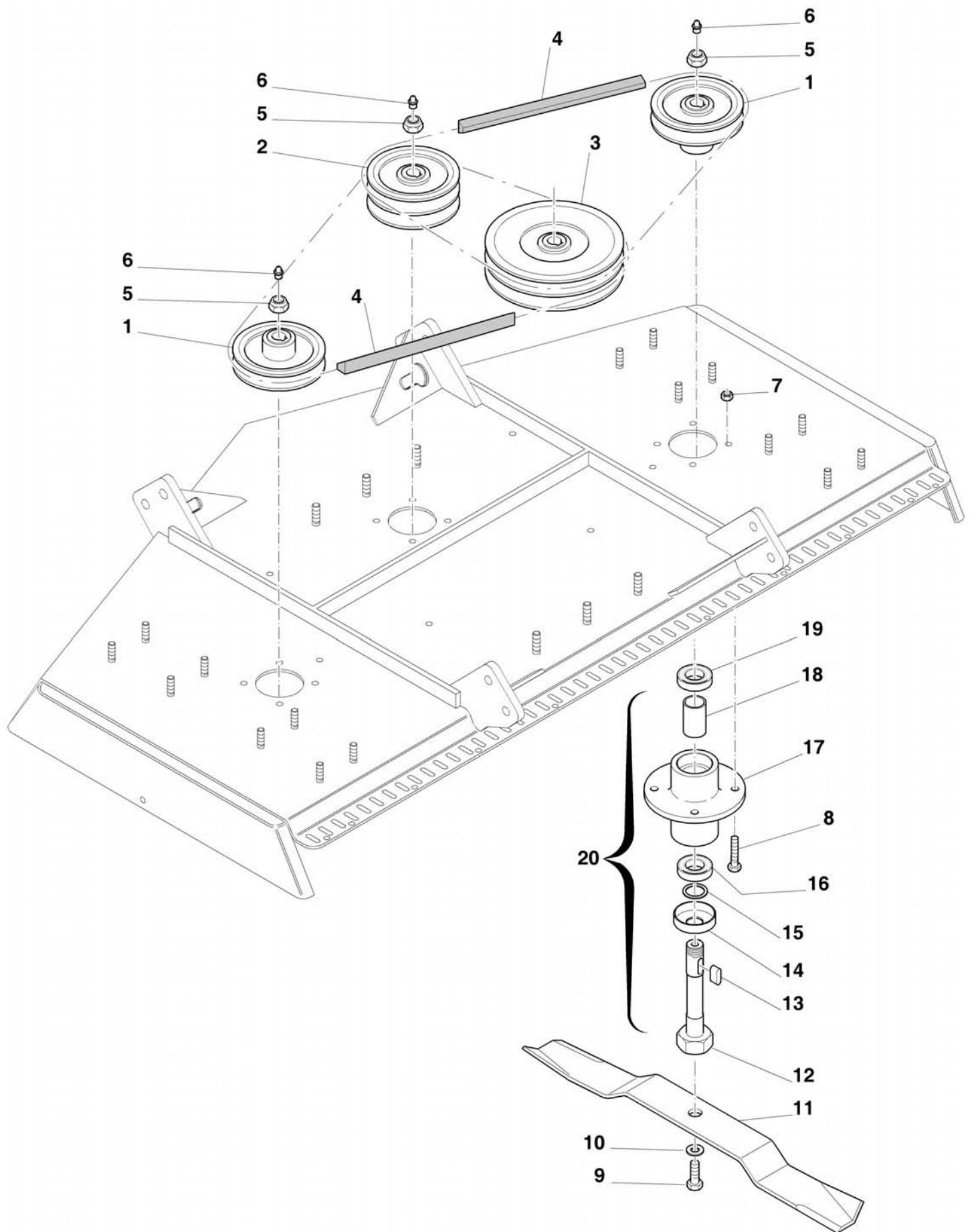

Ref.	Part #	Description	Qty.
1	000-6792	Pulley SPB 120x1, 4' frame	2
	000-6622	Pulley SPB 130x1, 5' frame	2
	000-6842	Pulley SPB 160x1, 6' frame	2
2	000-6791	Pulley SPB 120x2, 4' frame	1
	000-6621	Pulley SPB 130x2, 5' frame	1
	000-6841	Pulley SPB 160x2, 6' frame	1
3	000-6692	Pulley SPB 250x2	1
4	000-6798	Belt 5VX630, 4' frame	2
	000-6693	Belt 5VX710, 5' frame	2
	000-6848	Belt 5VX850, 6' frame	2
5	000-6698	Nut SP M25-1.50 Z	3
6	002-9036	Grease fitting Ø8, press in	3
7	003-0156	Nut PT M10-1.50 C6 TK Z	12
8	000-1278	Bolt HH M10-1.50x30 C8.8 Z F	12
9	000-6659	Bolt blade SP M14-1.50x32	3
10	000-8560	Washer conical spring Ø18 Z	3
11	000-6795	Blade standard, 4' frame	3
	000-6641	Blade standard, 5' frame	3
	000-6845	Blade standard, 6' frame	3
	000-6795M	Blade mulching, 4' frame (option)	3
	000-6641M	Blade mulching, 5' frame (option)	3
	000-6845M	Blade mulching, 6' frame (option)	3
	000-6795B	Blade high lift, 4' frame (option)	3
	000-6641B	Blade high lift, 5' frame (option)	3
	000-6845B	Blade high lift, 6' frame (option)	3
	000-6795F	Blade flat, 4' frame (option)	3
	000-6641F	Blade flat, 5' frame (option)	3
	000-6845F	Blade flat, 6' frame (option)	3
	000-6795G	Blade gator, 4' frame (option)	3
	000-6641G	Blade gator, 5' frame (option)	3
	000-6845G	Blade gator, 6' frame (option)	3
12	000-6649	Spindle shaft	3
13	000-6639	Key 8x7x25	3
14	000-6636	Cover	3
15	000-6606	Shim Ø25x35x2	3
16	000-6626A	Bearing 6205-ZZ	3
17	000-6648	Spindle	3
18	000-6640	Spacer, spindle	3
19	000-6634A	Bearing 6205-Z	3
20	000-6629C	Spindle assembly	-

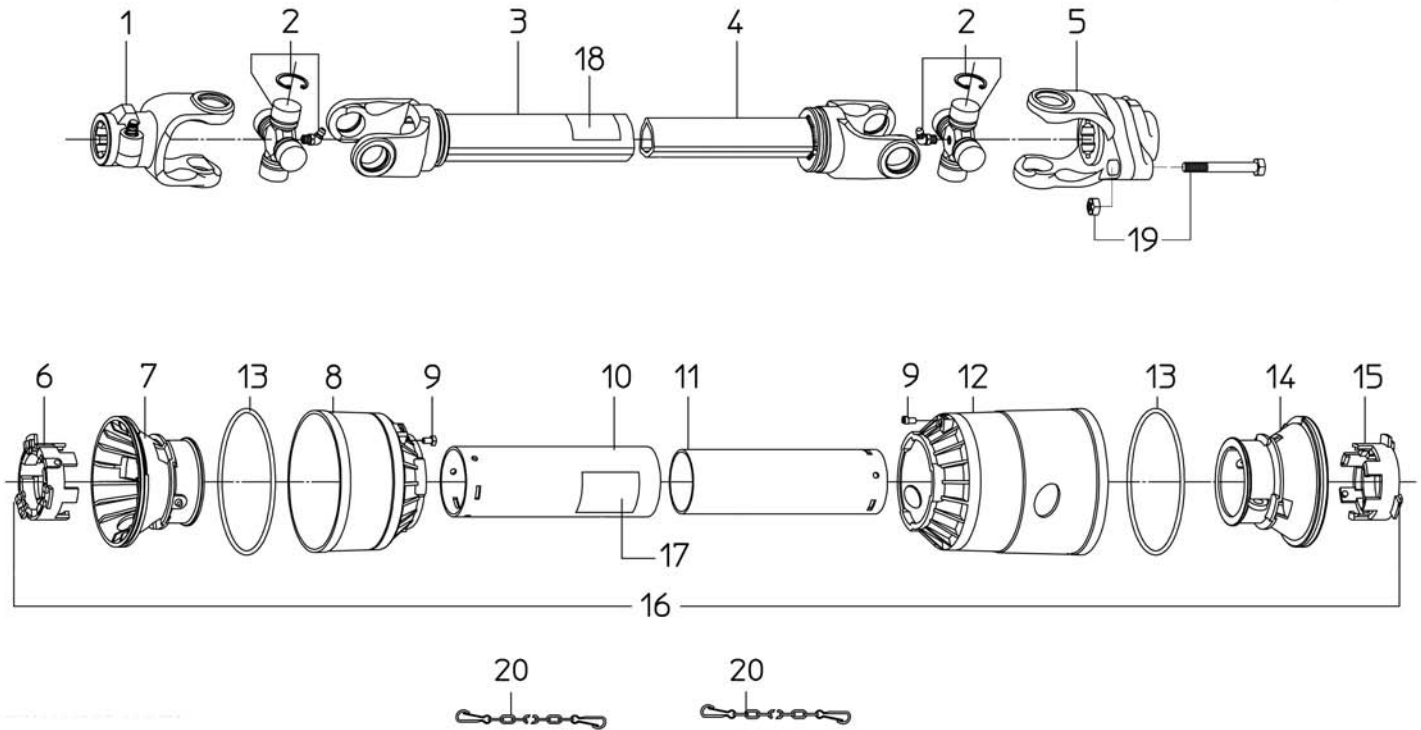

Ref.	Part #	Description	Qty.
1	1023010C	PTO yoke	1
2	1003020C	Cross & bearing	2
3	1943042NC	Outer tube	1
4	1953044NC	Inner tube	1
5	1023010C	PTO yoke; Ver. G & below	1
	1483037C	Yoke w/shear bolt; Ver. H & above	1
6	1784210C	Locking ring, outer tube; #275250 & below	1
7	1784201C	Rigid cone, outer tube; #275250 & below	1
8	1784203C	Standard cone; #275250 & below	1
9	1784212C	Pin; #275250 & below	2
10	1773040C	Shield, outer tube	1
11	1872040C	Shield, inner tube	1
12	1784205C	Long cone; #275250 & below	1
13	1213233C	Stiffening ring; #275250 & below	2
14	1784202C	Rigid cone, inner tube; #275250 & below	1
15	1784211C	Locking ring, inner tube; #275250 & below	1
16	90SL4040C	Shield, complete ³	1
17	950-463B	Decal "DANGER - Rotating driveline, keep away" outer shield	1
18	950-464B	Decal "DANGER - Guard missing, do not operate" outer tube	1
19	000-508E	Shear bolt; Ver. H & above	1
20	1006065C	Chain, anti-rotation	2
	050-0413	Driveline, complete; Ver. G & below	-
	050-0475	Driveline w/shear bolt, complete; Ver. H & above	-

³ Complete shielding is interchangeable with part #96SL4040C.

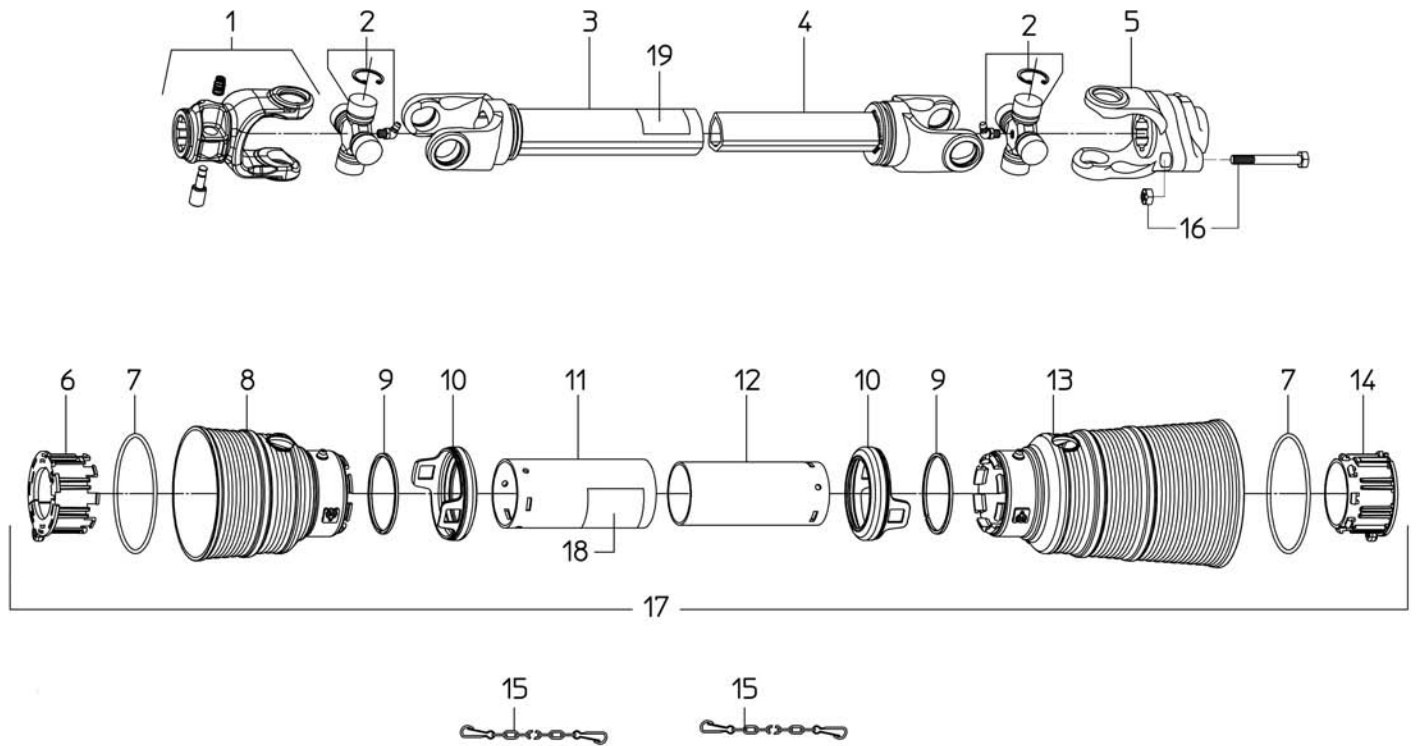

Ref.	Part #	Description	Qty.
1	1023010C	PTO yoke	1
2	1003020C	Cross & bearing	2
3	1943042NC	Outer tube	1
4	1953044NC	Inner tube	1
5	1483037C	Yoke w/shear bolt	1
6	1784710C	Locking ring, outer tube; #275251 & above	1
7	1211733C	Stiffening ring; #275251 & above	2
8	1781703C	Standard cone; #275251 & above	1
9	1211735C	Safety ring; #275251 & above	2
10	1881709C	Safety sleeve; #275251 & above	2
11	1773040C	Shield, outer tube	1
12	1872040C	Shield, inner tube	1
13	1781704C	Long cone; #275251 & above	1
14	1784711C	Locking ring, Inner tube; #275251 & above	1
15	1006065C	Chain, anti-rotation	2
16	000-508E	Shear bolt	1
17	96SL4040C	Shield, complete	1
18	950-463B	Decal "DANGER - Rotating driveline, keep away" outer shield	1
19	950-464B	Decal "DANGER - Guard missing, do not operate" outer tube	1
	050-0475	Driveline w/shear bolt, complete	-

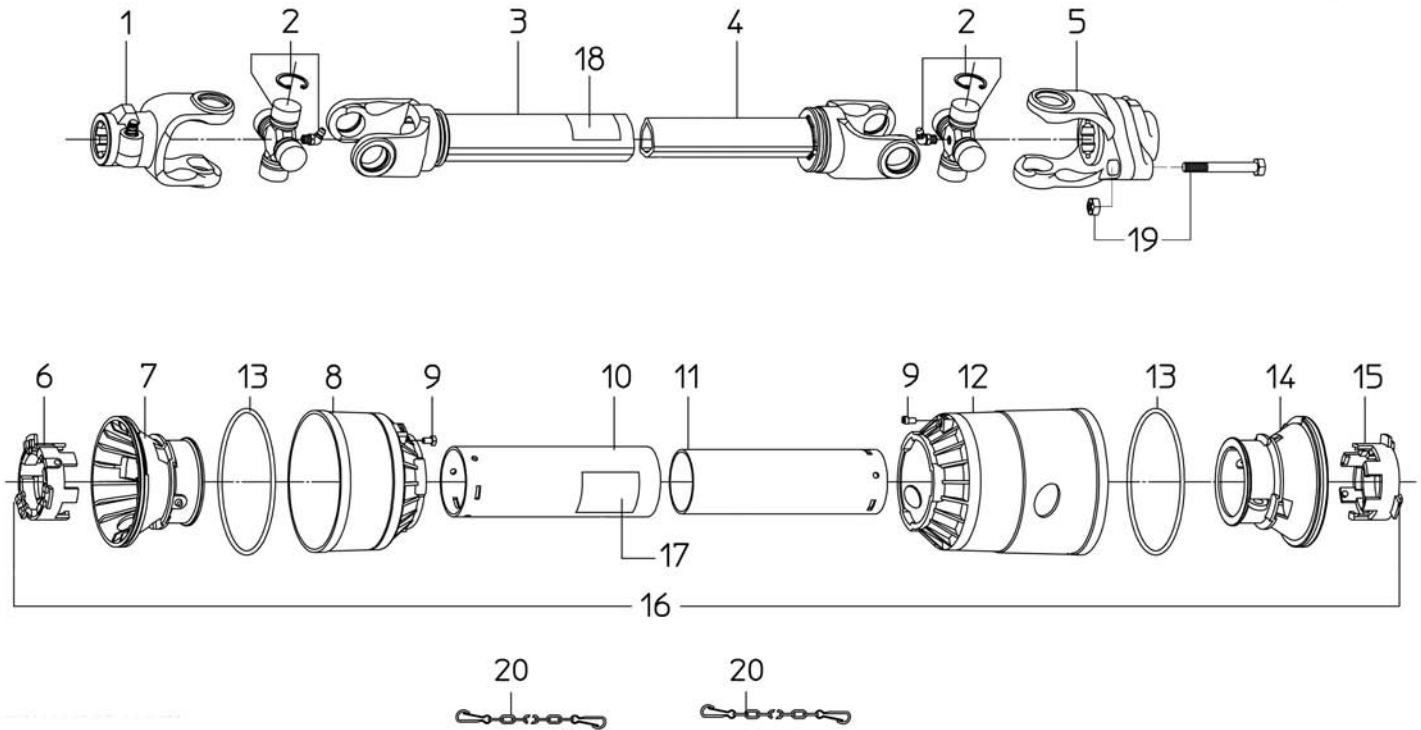

Ref.	Part #	Description	Qty.
1	1023010C	PTO yoke	1
2	1003020C	Cross & bearing	2
3	1943055NC	Outer tube	1
4	1953057NC	Inner tube	1
5	1023010C	PTO yoke; Ver. G & below	1
	1483037C	Yoke w/shear bolt; Ver. H & above	1
6	1784210C	Locking ring, outer tube; #275250 & below	1
7	1784201C	Rigid cone, outer tube; #275250 & below	1
8	1784203C	Standard cone; #275250 & below	1
9	1784212C	Pin; #275250 & below	2
10	1773053C	Shield, outer tube	1
11	1872053C	Shield, inner tube	1
12	1784205C	Long cone; #275250 & below	1
13	1213233C	Stiffening ring; #275250 & below	2
14	1784202C	Rigid cone, inner tube; #275250 & below	1
15	1784211C	Locking ring, inner tube; #275250 & below	1
16	90SL4053C	Shield, complete ⁴	1
17	950-463B	Decal "DANGER - Rotating driveline, keep away" outer shield	1
18	950-464B	Decal "DANGER - Guard missing, do not operate" outer tube	1
19	000-508E	Shear bolt; Ver. H & above	1
20	1006065C	Chain, anti-rotation	2
	050-0414	Driveline, complete; Ver. G & below	-
	050-0476	Driveline w/shear bolt, complete; Ver. H & above	-

⁴ Complete shielding is interchangeable with part #96SL4053C.

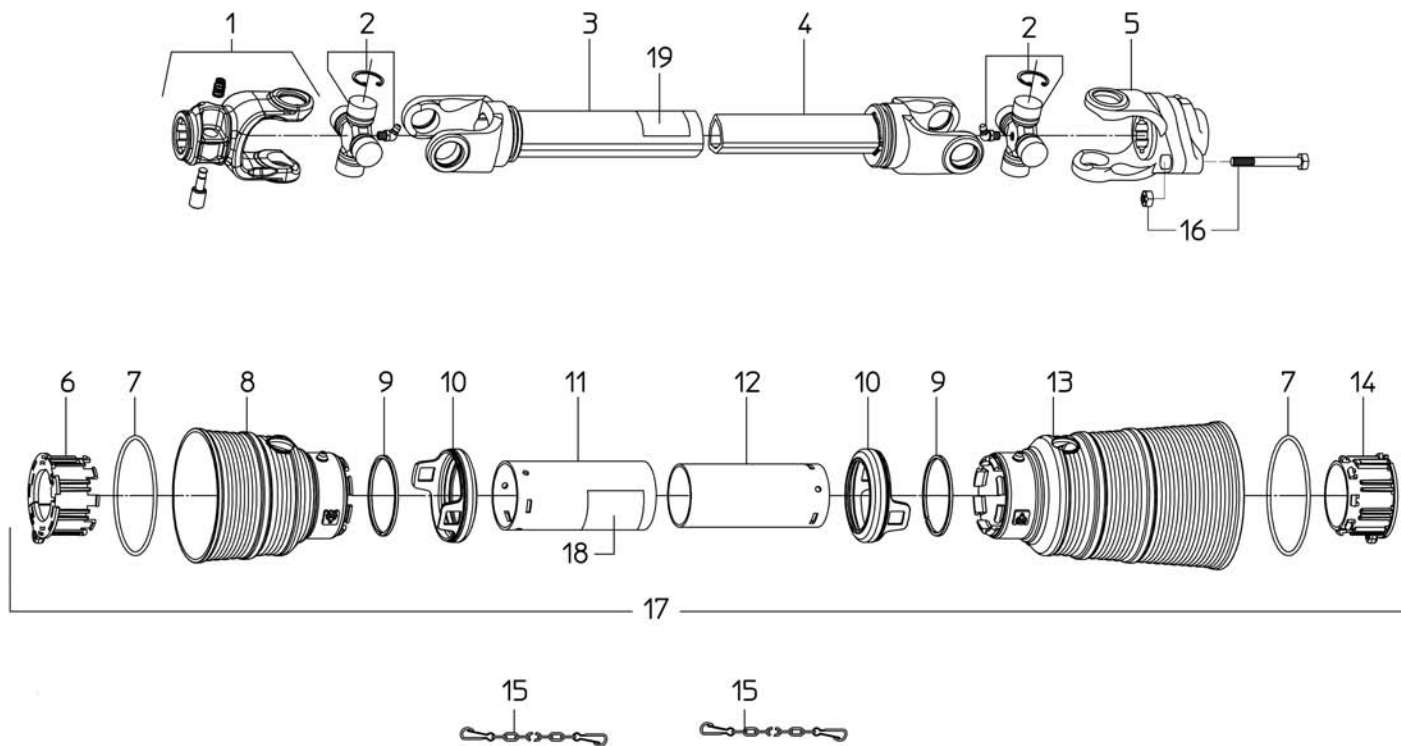

Ref.	Part #	Description	Qty.
1	1023010C	PTO yoke	1
2	1003020C	Cross & bearing	2
3	1943055NC	Outer tube	1
4	1953057NC	Inner tube	1
5	1483037C	Yoke w/shear bolt	1
6	1784710C	Locking ring, outer tube; #275251 & above	1
7	1211733C	Stiffening ring; #275251 & above	2
8	1781703C	Standard cone; #275251 & above	1
9	1211735C	Safety ring; #275251 & above	2
10	1881709C	Safety sleeve; #275251 & above	2
11	1773053C	Shield, outer tube	1
12	1872053C	Shield, inner tube	1
13	1781704C	Long cone; #275251 & above	1
14	1784711C	Locking ring, inner tube; #275251 & above	1
15	1006065C	Chain, anti-rotation	2
16	000-508E	Shear bolt	1
17	96SL4053C	Shield, complete	1
18	950-463B	Decal "DANGER - Rotating driveline, keep away" outer shield	1
19	950-464B	Decal "DANGER - Guard missing, do not operate" outer tube	1
	050-0476	Driveline w/shear bolt, complete	-

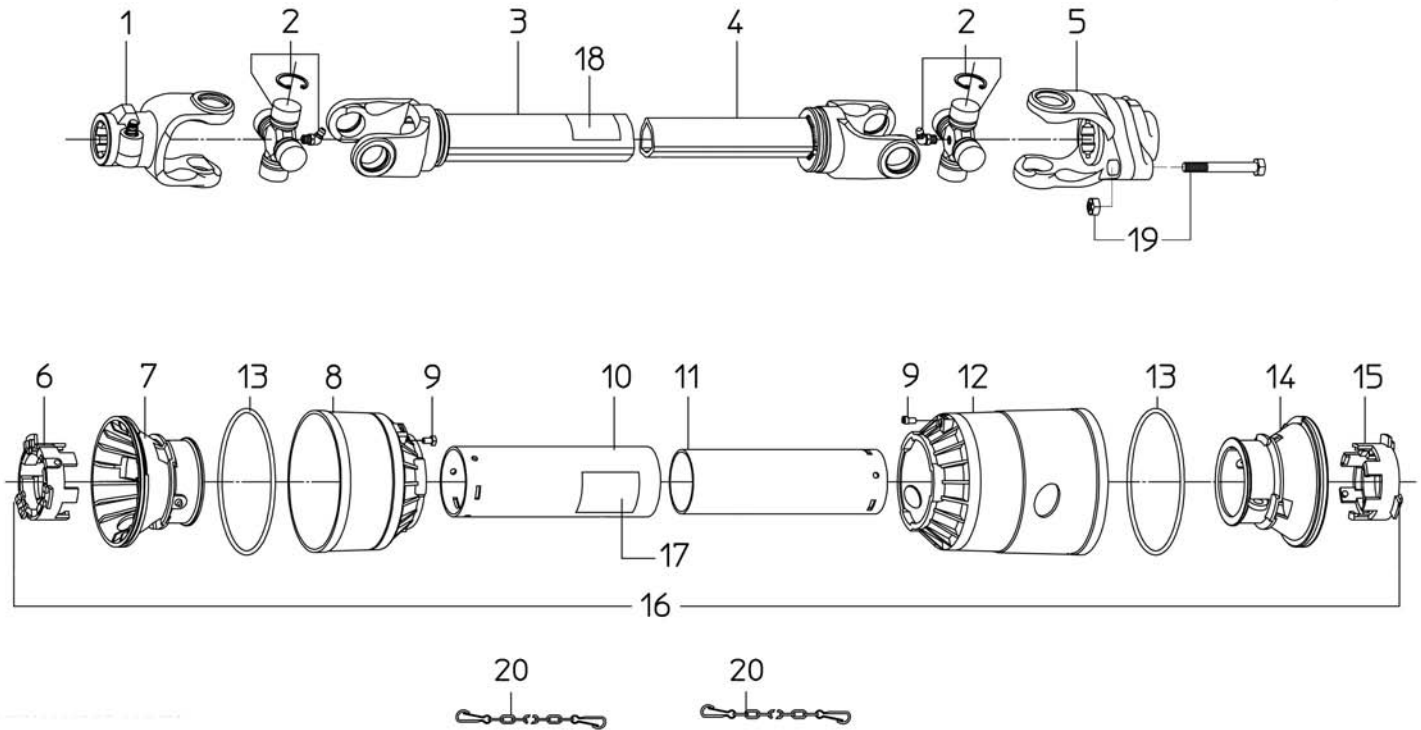

Ref.	Part #	Description	Qty.
1	1023010C	PTO yoke	1
2	1003020C	Cross & bearing	2
3	1943070NC	Outer tube	1
4	1953072NC	Inner tube	1
5	1023010C	PTO yoke; Ver. G & below	1
	1483037C	Yoke w/shear bolt; Ver. H & above	1
6	1784210C	Locking ring, outer tube; #275250 & below	1
7	1784201C	Rigid cone, outer tube; #275250 & below	1
8	1784203C	Standard cone; #275250 & below	1
9	1784212C	Pin; #275250 & below	2
10	1773068C	Shield, outer tube	1
11	1872068C	Shield, inner tube	1
12	1784205C	Long cone; #275250 & below	1
13	1213233C	Stiffening ring; #275250 & below	2
14	1784202C	Rigid cone, inner tube; #275250 & below	1
15	1784211C	Locking ring, inner tube; #275250 & below	1
16	90SL4068C	Shield, complete ⁵	1
17	950-463B	Decal "DANGER - Rotating driveline, keep away" outer shield	1
18	950-464B	Decal "DANGER - Guard missing, do not operate" outer tube	1
19	000-508E	Shear bolt; Ver. H & above	1
20	1006065C	Chain, anti-rotation	2
	050-0415	Driveline, complete; Ver. G & below	-
	050-0477	Driveline w/shear bolt, complete; Ver. H & above	-

⁵ Complete shielding is interchangeable with part #96SL4068C.

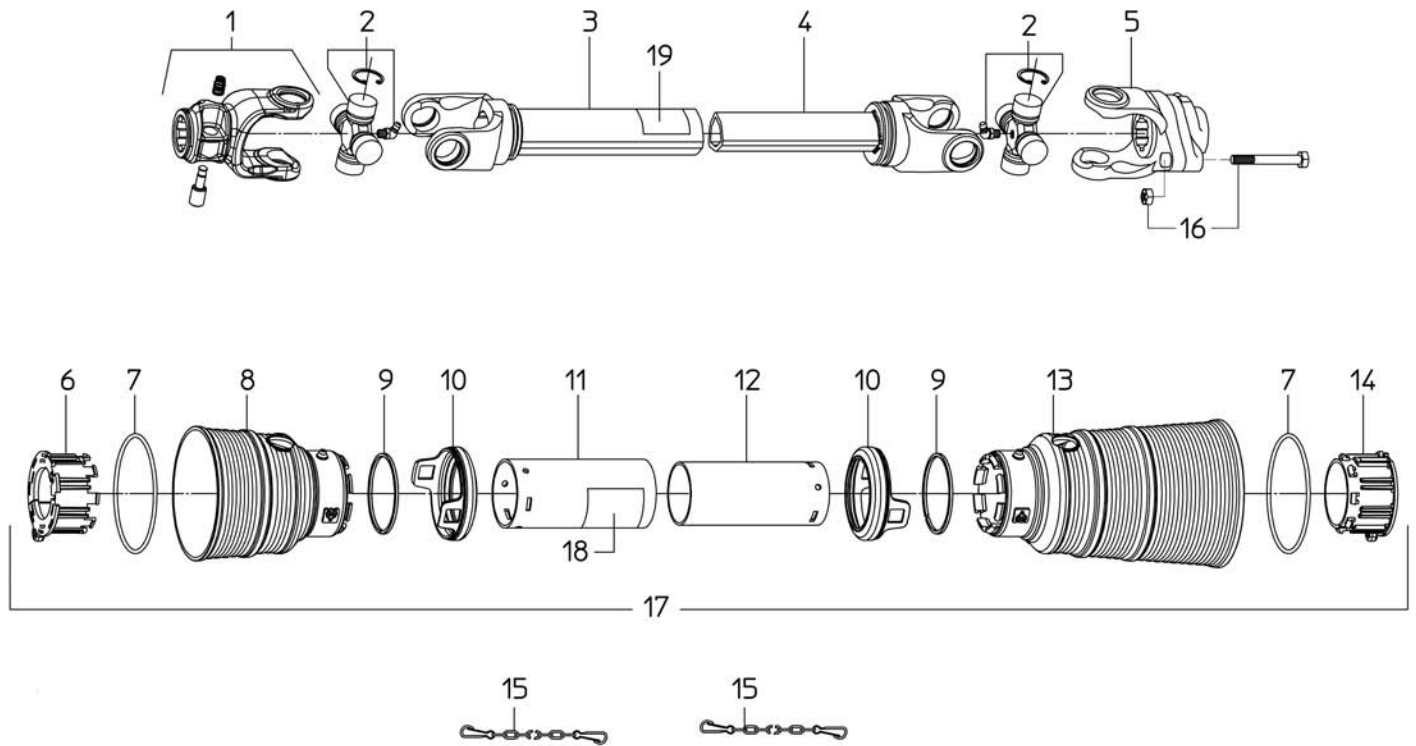

Ref.	Part #	Description	Qty.
1	1023010C	PTO yoke	1
2	1003020C	Cross & bearing	2
3	1943070NC	Outer tube	1
4	1953072NC	Inner tube	1
5	1483037C	Yoke w/shear bolt	1
6	1784710C	Locking ring, outer tube; #275251 & above	1
7	1211733C	Stiffening ring; #275251 & above	2
8	1781703C	Standard cone; #275251 & above	1
9	1211735C	Safety ring; #275251 & above	2
10	1881709C	Safety sleeve; #275251 & above	2
11	1773068C	Shield, outer tube	1
12	1872068C	Shield, inner tube	1
13	1781704C	Long cone; #275251 & above	1
14	1784711C	Locking ring, inner tube; #275251 & above	1
15	1006065C	Chain, anti-rotation	2
16	000-508E	Shear bolt	1
17	96SL4068C	Shield, complete	1
18	950-463B	Decal "DANGER - Rotating driveline, keep away" outer shield	1
19	950-464B	Decal "DANGER - Guard missing, do not operate" outer tube	1
	050-0477	Driveline w/shear bolt, complete	-

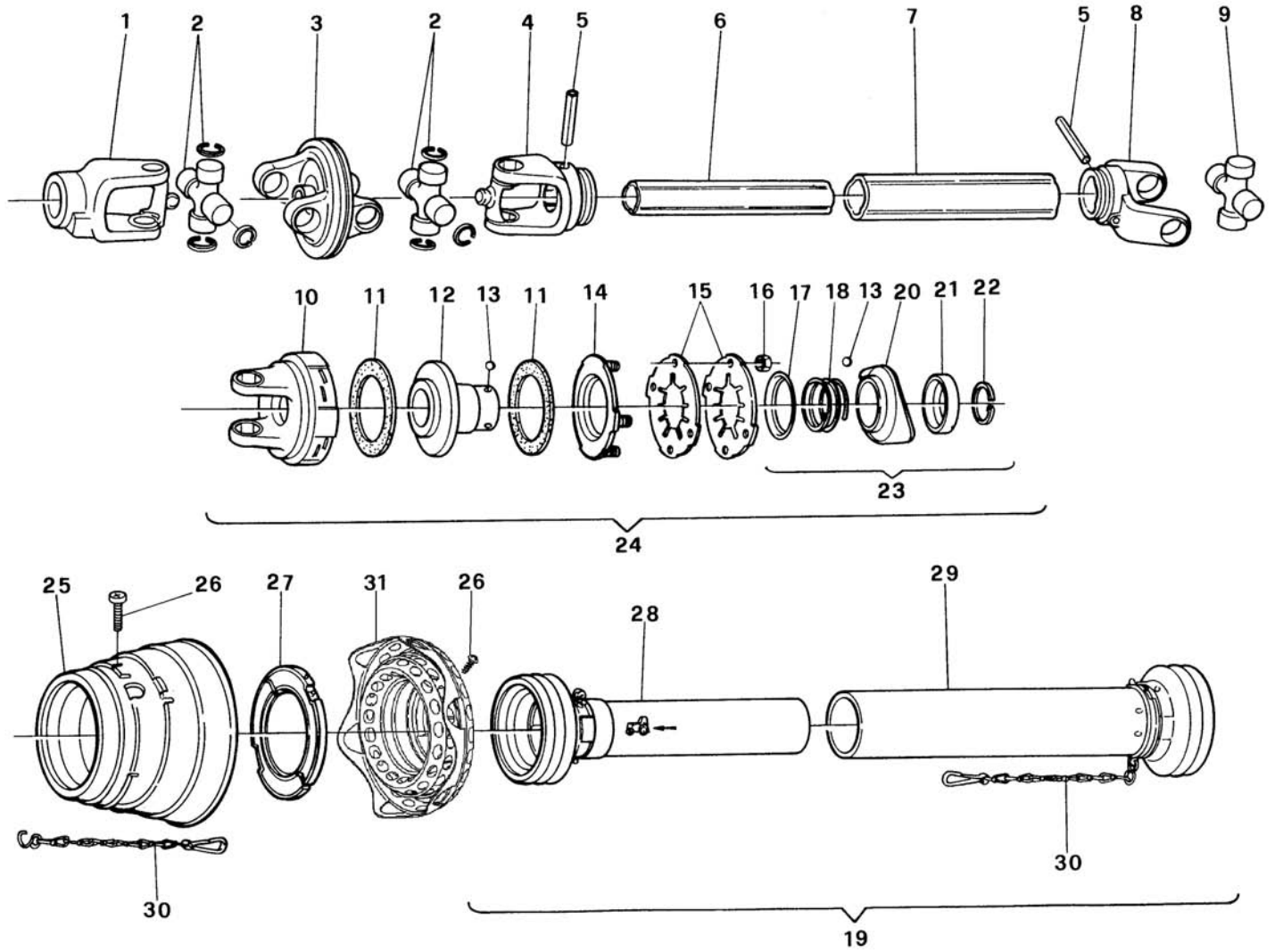

Ref.	Part #	Description	Qty.
1	366838W	PTO yoke 2380; Ver. D & below	1
	134548W	PTO yoke 2380; Ver. E & above	1
2	382701W	Cross & bearing 2380; Ver. D & below	2
	116550W	Cross & bearing 2380; Ver. E & above	2
3	384517W	Double yoke 2380	1
4	366862W	Yoke, inner tube 2380	1
5	020616W	Roll pin Ø10x75	2
6	046753W	Inner tube 2380; Ver. D & below	1
	135895W	Inner tube 2380; Ver. E & above	1
7	054602W	Outer tube 2380; Ver. D & below	1
	135897W	Outer tube 2380; Ver. E & above	1
8	041577W	Yoke, outer tube 2380	1
9	044444W	Cross & bearing	1
10	185836W	Clutch housing	1
11	168556W	Friction disc	2
12	051551W	Rotor	1
13	020692W	Lock roller	6
14	381495W	Thrust plate	1
15	043489W	Disc spring	2
16	381957W	Nut	4
17	047825W	Back up ring	1
18	045793W	Spring	1
19	106724W	Shield, complete; Ver. D & below	1
	693275W	Shield, complete; Ver. E & above	1
20	045790W	Bushing	1
21	338531W	Back up ring	1
22	304149W	Snap ring	1
23	341953W	Quick disconnecting lock	1
24	317189W	Slip clutch, complete	1
25	365715W	Protection; Ver. D & below	1
	134401W	Protection; Ver. E & above	1
26	365305W	Bolt	10
27	365717W	Bearing ring	1
28	185530W	Shield, outer tube; Ver. D & below	1
	116475W	Shield, outer tube; Ver. E & above	1
29	368508W	Shield, inner tube	1
30	044321W	Chain, anti-rotation	2
31	134847W	Guard cone; Ver. E & above	1
	050-0040	Main driveline, complete; Ver. D & below ⁶	-
	050-0042	Main driveline, complete; Ver. E & above	-
	950-463B	Decal "DANGER - Rotating driveline, keep away" outer shield	1
	950-464B	Decal "DANGER - Guard missing, do not operate" outer tube	1

⁶ Interchangeable with driveline #050-0042.

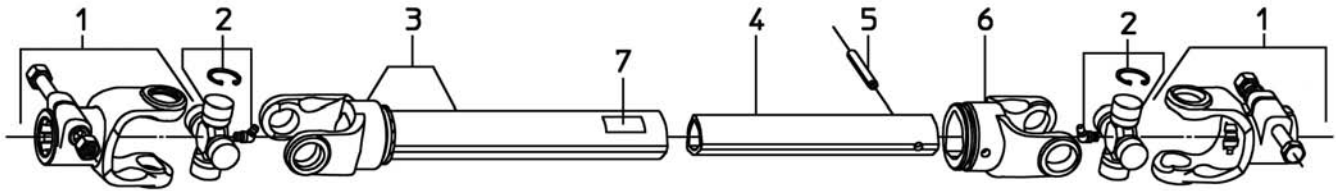

Ref.	Part #	Description	Qty.
1	1106010C	PTO yoke	2
2	1006020C	Cross & bearing	2
3	1906022WC	Outer tube	1
4	1526030C	Inner tube	1
5	000-016E	Roll pin Ø10x70	1
6	1706029C	Yoke, inner tube	1
7	950-464B	Decal "DANGER - Guard missing, do not operate" outer tube	1
	050-0485	PTO shaft, complete; Ver. H & above	1

Use only original spare parts

All rights reserved. It is unlawful to copy, reprint or use any of the information or details in this manual without the expressed written permission of the Company. Technical information provided in this manual is approximate, the Company reserves the right to modify or improve the models shown for technical or commercial purposes. Pictures in this manual do not necessarily show the machine as delivered.

BEFCO[®]

P.O. Box 6036
Rocky Mount, NC 27802-6036
Tel.: 252.977.9920 - Fax: 252.977.9718
www.befco.com

