

# **BEFCO<sup>®</sup>**

## **Operator's Manual**

### **SEED-RITE**

**Primary full-width seed broadcaster**

**SRT-074**

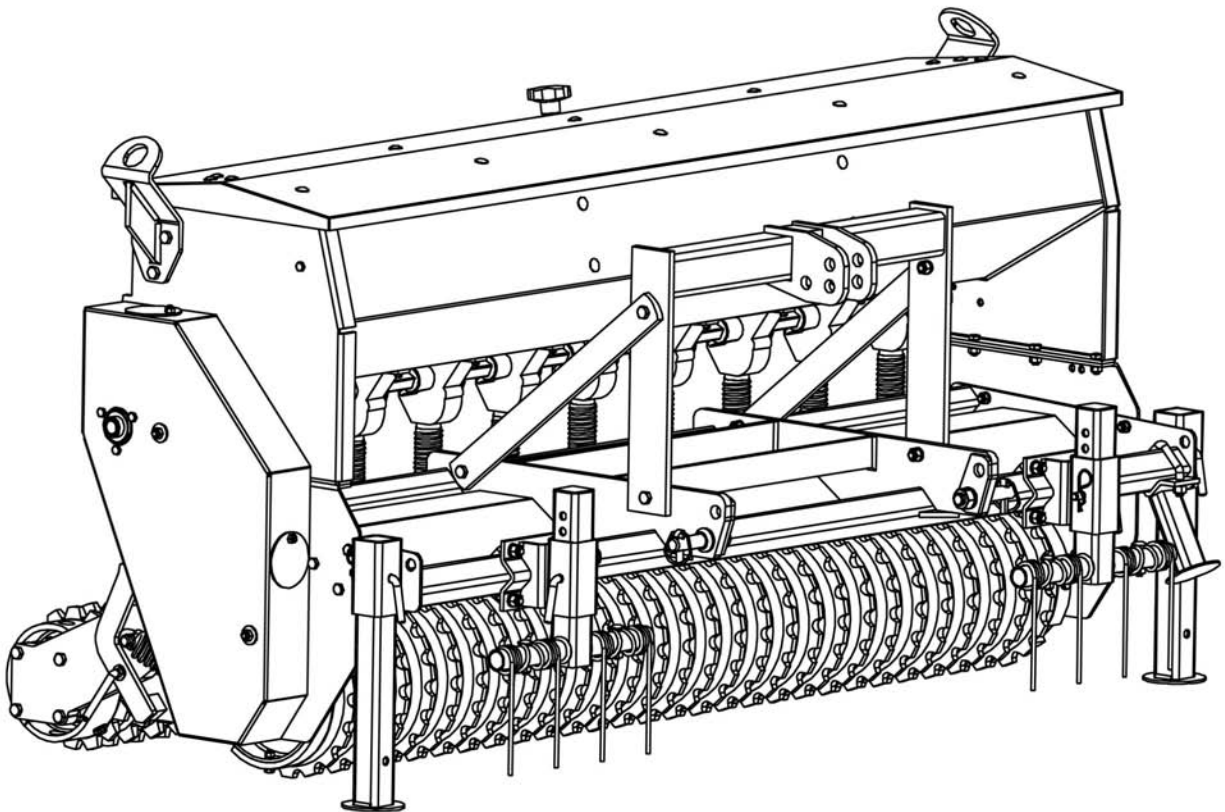

The operator's manual is a technical service guide and must always accompany the machine.

**Manual 971-395B**

**June 2010**

# SAFETY

Take note! This safety alert symbol found throughout this manual is used to call your attention to instructions involving your personal safety and the safety of others. Failure to follow these instructions can result in injury or death.



*This symbol means:  
ATTENTION!  
BECOME ALERT!  
YOUR SAFETY IS INVOLVED!*

## Signal Words

Note the use of the signal words DANGER, WARNING and CAUTION with the safety messages. The appropriate signal words for each have been selected using the following guidelines:



**DANGER:** Indicates an imminently hazardous situation that, if not avoided, will result in death or serious injury.



**WARNING:** Indicates a potentially hazardous situation that, if not avoided, could result in death or serious injury, and includes hazards that are exposed when guards are removed. It may also be used to alert against unsafe practices.



**CAUTION:** Indicates a potentially hazardous situation that, if not avoided, may result in minor or moderate injury.

# INDEX

<b>1 - GENERAL INFORMATION</b>	4
1.01 - General	4
1.02 - Model and Serial Number ID	5
<b>2 - SAFETY PRECAUTIONS</b>	6
2.01 - Preparation	6
2.02 - Starting and Stopping	7
2.03 - Messages and Signs	7
<b>3 - OPERATION</b>	9
3.01 - Operational Safety	9
3.02 - Set Up	11
3.03 - Pre-Operational Check	11
3.04 - Attaching to the Tractor	12
3.05 - General Instructions for Use	13
3.06 - Hopper Adjustment	14
3.07 - Seed (or Fertilizer) Hopper Calibration	16
3.08 - Tickler Tine Bar (Option)	18
3.09 - Start Up	19
3.10 - Test Run	20
3.11 - Working Speed	20
3.12 - Headland Procedure	20
3.13 - Uneven Terrain	21
3.14 - Transporting	21
<b>4 - MAINTENANCE</b>	24
4.01 - Maintenance Safety	24
4.02 - Service	25
<b>5 - REPAIR PROCEDURES</b>	27
5.01 - Chain Case and Chain Replacement	27
5.02 - Front Roller Replacement	28
5.03 - Suggested Spare Parts	28
5.04 - Storage	29
<b>6 - TROUBLESHOOTING</b>	30
<b>7 - PRE-DELIVERY CHECKLIST</b>	31
<b>8 - WARRANTY</b>	32
<b>PARTS MANUAL</b>	37

# 1 - GENERAL INFORMATION

Thank you and congratulations for having chosen our implement. Your new Seed-Rite is a technologically advanced machine constructed of high quality, sturdy components that will fulfill your working expectations.

The Seed-Rite is the ideal machine for sport fields, parks, golf courses, airports, turf farm operations and anywhere the combination of lower labor costs and a professionally finished job is essential.

Read this manual carefully. It will instruct you on how to operate and service your implement safely and correctly. Failure to do so could result in personal injury and/or equipment damage.

## 1.01 - General



**CAUTION:** Unless otherwise specified, all hardware is metric. Use only metric tools on metric hardware. Other tools that do not fit properly can slip and cause injury.



**CAUTION:** Right hand and left hand sides of the implement are determined by facing in the direction the implement will travel when going forward (see fig. 2).

Carefully read the Warranty section<sup>1</sup>, detailing coverage and limitations of this warranty. **Warranty** is provided for customers who operate and maintain their equipment as described in this manual. Warranty registration is accomplished by the dealer by completing and forwarding the **Warranty Registration** form to the Company, along with a copy of the dealer's invoice. It is in your best interest to insure that this has been done.

Warranty does not cover the following:

1. Cleaning, transporting, mailing and service call charges.
2. Normal wear items such as chains, roller rings, seed cups, bearings, etc.
3. Depreciation or damage caused by normal wear, accidents, improper maintenance, improper protection or improper use.
4. The use of non-original spare parts and accessories.

Your Authorized Company Dealer has genuine parts in stock. Only these approved replacement parts should be used.

---

<sup>1</sup> See Chapter 8 - Warranty.

This limited warranty covers defective material and workmanship. The cost of normal maintenance or repairs for accidents or improper use and related labor will be borne by the owner.

### 1.02 - Model and Serial Number ID

Attached to the frame is an ID plate showing the model and the serial number. Record your implement model and serial number in the space provided below. Your dealer needs this information to give you prompt, efficient service when you order parts.

<b>BEFCO</b>	1781 S. Wesleyan Blvd. – P.O. Box 6036 Rocky Mount, N.C. 27802 – U.S.A. Tel: 1.252.977.9920 Fax: 1.252.977.9718
<b>MODEL:</b>	
<b>SERIAL:</b>	
<b>VERSION:</b>	

## 2 - SAFETY PRECAUTIONS

Safety is the primary concern in the design and manufacture of our products. Unfortunately our efforts to provide safe equipment can be wiped out by a single careless act of an operator.

In addition to the design and configuration of equipment, hazard control and accident prevention are dependent upon the awareness, concern, prudence and proper training of personnel involved in the operation, transport, maintenance and storage of equipment. It is the operator's responsibility to read and understand all safety and operating instructions in the manual and to follow these.

Allow only properly trained personnel to operate the implement. Working with unfamiliar equipment can lead to careless injuries. Read this manual, and the manual for your tractor, before assembly or operation, to acquaint yourself with the machines. It is the implement owner's responsibility, if this machine is used by any person other than yourself, is loaned or rented, to make certain that the operator, prior to operating, reads and understands the operator's manuals and is instructed in safe and proper use.

### 2.01 - Preparation



1. Before operating equipment read and understand the operator's manual and the safety signs (**see fig. 2**).
2. Thoroughly inspect the implement before initial operation to assure that all packaging materials, i.e., wires, bands, and tape have been removed.
3. Personal protection equipment including hard hat, safety glasses, safety shoes, and gloves are recommended during assembly, installation, operation, adjustment, maintaining and/or repairing the implement.
4. Operate the implement only with a tractor equipped with an approved Roll-Over-Protective-System (ROPS). Always wear your seat belt. Serious injury or even death could result from falling off the tractor.
5. Clear area to be cut of stones, branches or other debris that might be thrown, causing injury or damage.
6. Operate only in daylight or good artificial light.
7. Ensure the implement is properly mounted, adjusted and in good operating condition.
8. Ensure that all safety shielding and safety signs are properly installed and in good condition.

## 2.02 - Starting and Stopping



1. Be sure that no one is near the machine prior to engaging or while the machine is working.
2. Be sure the tractor is in "Neutral" before starting engine.
3. Equipment operating power is ground driven. Know how to stop the tractor quickly in case of an emergency.
4. After striking an obstacle, shut the tractor off, remove key and thoroughly inspect for damage before restarting.

## 2.03 - Messages and Signs



1. Read and adhere to all safety and operating decals on this machine (**see fig. 2**).
2. Before dismounting tractor: Allow moving parts to stop, stop engine, set brake and remove the key of unattended equipment.
3. Keep away from rotating parts.
4. Keep guards and shields in place and in good condition.
5. Do not use with bystanders in area.
6. Allow no riders on tractor or implement.
7. Allow moving parts to stop before repair.
8. Securely support implement before working underneath.

Additional warning and operating decals are available at no extra charge. Please specify model and serial number when ordering.

Fig. 2 - Safety decals; replace immediately if damaged.

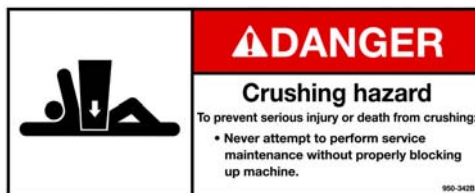
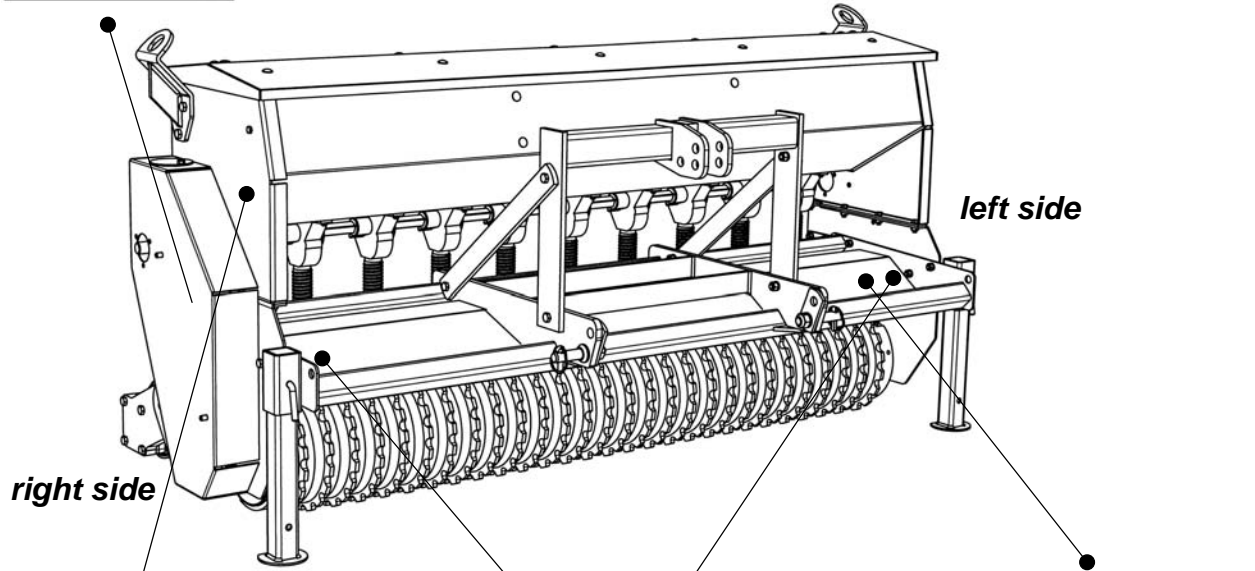
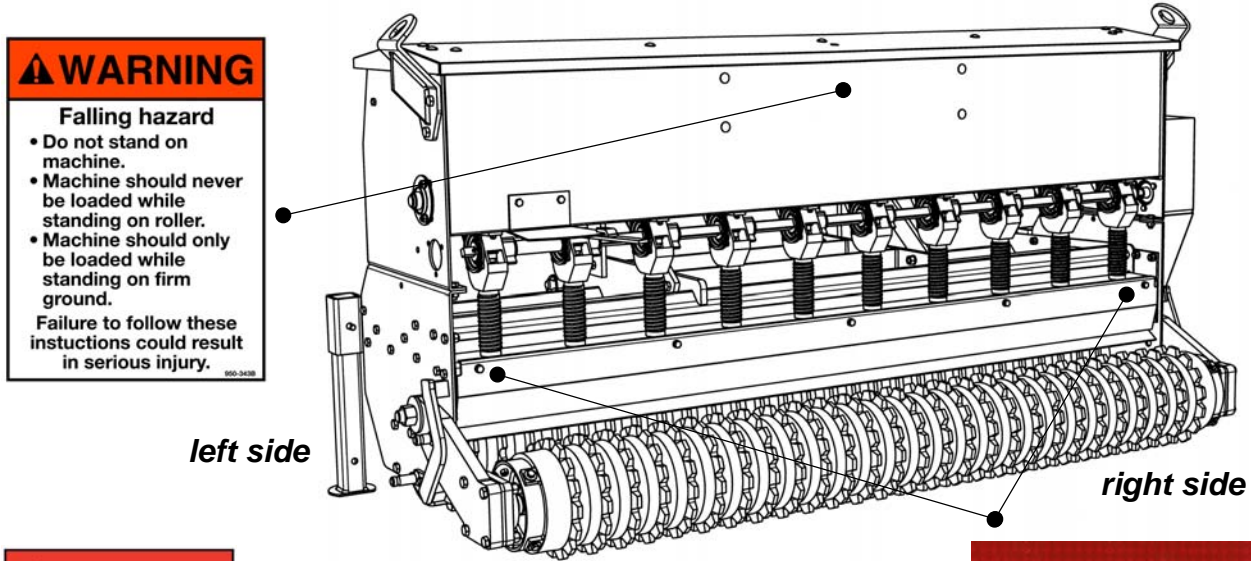



## 3 - OPERATION

The Seed-Rite is a primary full width seed broadcaster ideal for seeding a wide variety of grasses in lawns, golf courses, parks, sports fields and hay fields. Seeds are precisely metered and placed at the ideal depth for proper seed germination.

Engineered for tractors ranging from 25 to 70 HP, the Seed-Rite has a working width of 74". The seeder features a 6.7 cu. ft. capacity hopper equipped with 10 high precision metering seed cups made of a special nylon/fiberglass composite that allows them to work in both extremely warm or cold climates. The seed cups are placed 7" apart to allow a uniform seed distribution across the full width of the machine.

The forward movement of the front corrugated roller turns the chain transmission on the right side of the machine which engages the metering cups and stirrer inside the hopper. This allows the machine to spread seed only while it is in movement and therefore avoids any seed going to waste.

The front corrugated roller, equipped with 28 rings, evens out the surface and prepares the seed bed while the smaller rear corrugated roller equipped with 27 rings, helps incorporate the seed into the ground and gently applies pressure through the 2 side springs to compact the surface after the seed has been placed.

The light weight and durable nylon/fiberglass composite roller rings which are supplied standard with the Seed-Rite also help contain the overall weight of the machine making it easier to use with the lower horsepower tractors. Cast iron roller rings are available as an option and are ideal when more pressure on the soil is needed.

The unit is also equipped with 2 adjustable spring tine track removers mounted in front of the machine.

As an option the Seed-Rite can mount two rear roller extensions with a tickler tine bar that acts as a rake and allows for greater seed penetration into the soil improving germination.

### 3.01 - Operational Safety



**CAUTION:** Our machines are designed considering safety as the most important aspect and are the safest available in today's market. Unfortunately, human carelessness can override the safety features built into our machines. Injury prevention and work safety, aside from the features on our seeders, are very much due to the responsible use of the equipment. It must always be operated prudently following with great care, the safety instructions laid out in this manual.



1. The use of this equipment is subject to certain hazards which cannot be prevented by mechanical means or product design. All operators of this equipment must read

- and understand this entire manual, paying particular attention to safety and operating instructions, prior to using.
2. Do not operate the tractor and implement when you are tired, sick or when using medication.
  3. Keep all helpers and bystanders at least 50 feet from the machine. Only properly trained people should operate this machine.
  4. The majority of accidents involve operators being knocked off the tractor by low hanging limbs and then being run over by the implement. Accidents are most likely to occur with machines that are loaned or rented to someone who has not read the operator's manual and is not familiar with the implement.
  5. Always stop the tractor, set brake, shut off the tractor engine, remove the ignition key, lower implement to the ground and allow rotating parts to come to a complete stop before dismounting tractor. Never leave equipment unattended with the tractor running.
  6. Never place hands or feet under implement with tractor engine running or before you are sure all motion has stopped. Stay clear of all moving parts.
  7. Do not reach or place yourself under equipment until it is blocked securely.
  8. Do not allow riders on the implement or tractor at any time. There is no safe place for riders.
  9. Do not operate unless all personnel, livestock and pets are 50 feet away to prevent injury by thrown objects.
  10. Before backing up, disengage the implement and look behind carefully.
  11. Install and secure all guards and shields before starting or operating.
  12. Keep hands, feet, hair and clothing away from moving parts.
  13. Never operate tractor and implement under trees with low hanging limbs. Operators can be knocked off the tractor and then run over by the implement.
  14. Stop implement immediately upon striking an obstruction. Turn engine off, remove key, inspect and repair any damage before resuming operation.
  15. Stay alert for holes, rocks and roots in the terrain and other hidden hazards. Keep away from drop-offs.
  16. Use extreme care and maintain minimum ground speed when transporting on hillside, over rough ground and when operating close to ditches or fences. Be careful when turning sharp corners.
  17. Reduce speed on slopes and sharp turns to minimize tipping or loss of control. Be careful when changing directions on slopes. Do not start or stop suddenly on slopes. Avoid operation on steep slopes.
  18. When using a unit, a minimum 20% of tractor and equipment weight must be on tractor front wheels. Without this weight, tractor could tip over, causing personal injury or death. The weight may be attained with a front end loader, front wheel weights, ballast in tires or front tractor weights. When attaining a minimum 20% of tractor and equipment weight on the front wheels, you must not exceed the ROPS weight certification. Weigh the tractor and equipment. Do not guess or estimate!
  19. Inspect the entire machine periodically<sup>2</sup>. Look for loose fasteners, worn or broken parts, and leaky or loose fittings.

---

<sup>2</sup> See Chapter 4 - Maintenance.

20. Pass diagonally through sharp dips and avoid sharp drops to prevent "hanging up" tractor and implement.
21. Avoid sudden starts and stops while traveling up or downhill.
22. Always use down slopes; never across the face. Avoid operation on steep slopes. Slow down on sharp turns and slopes to prevent tipping and/or loss of control.

### 3.02 - Set Up

**Notice to dealer:** Pre-delivery setup and service including lubrication is the responsibility of the authorized dealer. It is up to him to assure that the machine is in perfect condition and ready to be used. It is his responsibility to ensure that the customer is aware of all safety aspects and operational procedures for the implement. He must also fill out the Pre-Delivery Checklist<sup>3</sup> prior to delivering the implement.



**CAUTION:** Stand clear of bands when cutting as they could be under sufficient tension to cause them to fly loose. Take care in removing bands and wire. They often have extremely sharp edges and cut very easily.

### 3.03 - Pre-Operational Check

Although the machine usually arrives set up, ready to use, it is important to check certain aspects of the machine before using it. Adjustments are normally necessary in order to adapt the Seed-Rite to work under a given condition.



**DANGER:** Never trust the tractor hydraulics alone to support the machine. Never do any repairs or adjustments under the machine unless it is safely blocked.

Check each of the following, carefully, prior to engaging machine:

1. Ensure that the drive chains are well greased in the chain housing on the right side of the implement (**see fig. 11**). Drive chains are supplied with an automatic chain tensioner.
2. Grease all rollers supports (**see fig. 11**).
3. The hopper and seed cups to ensure they are mounted correctly.
4. No wrappings or foreign objects are on the machine.
5. All hardware for tightness, especially the bolts holding the 3 point hitch<sup>4</sup>.
6. All safety shields and guards are in their place and tightly attached.
7. No people or animals are in the work area.
8. When working, make sure that the rear roller locking pin has been removed.

<sup>3</sup> See Chapter 7 - Pre-Delivery Checklist.

<sup>4</sup> See Table 4, page 23.

9. When working, make sure the Seed-Rite has its full weight riding on the rollers (see fig. 4).

### 3.04 - Attaching to the Tractor

Unit may be used on tractors ranging from 35 to 70 HP with a category 1 three point hitch<sup>5</sup>.



**DANGER:** Never attempt to attach the Seed-Rite to the tractor or make any adjustments to it without first turning the tractor off.



**DANGER:** Failure to ensure a secure coupling of the implement to the tractor can cause injury and damage to the implement or tractor. If necessary, wheel weights, front tractor weights and/or tire ballast should be used to improve stability. Be sure that the tractor tire pressure is correct. It is important to strictly follow the safety guidelines and instructions laid out in the tractor operator's manual.

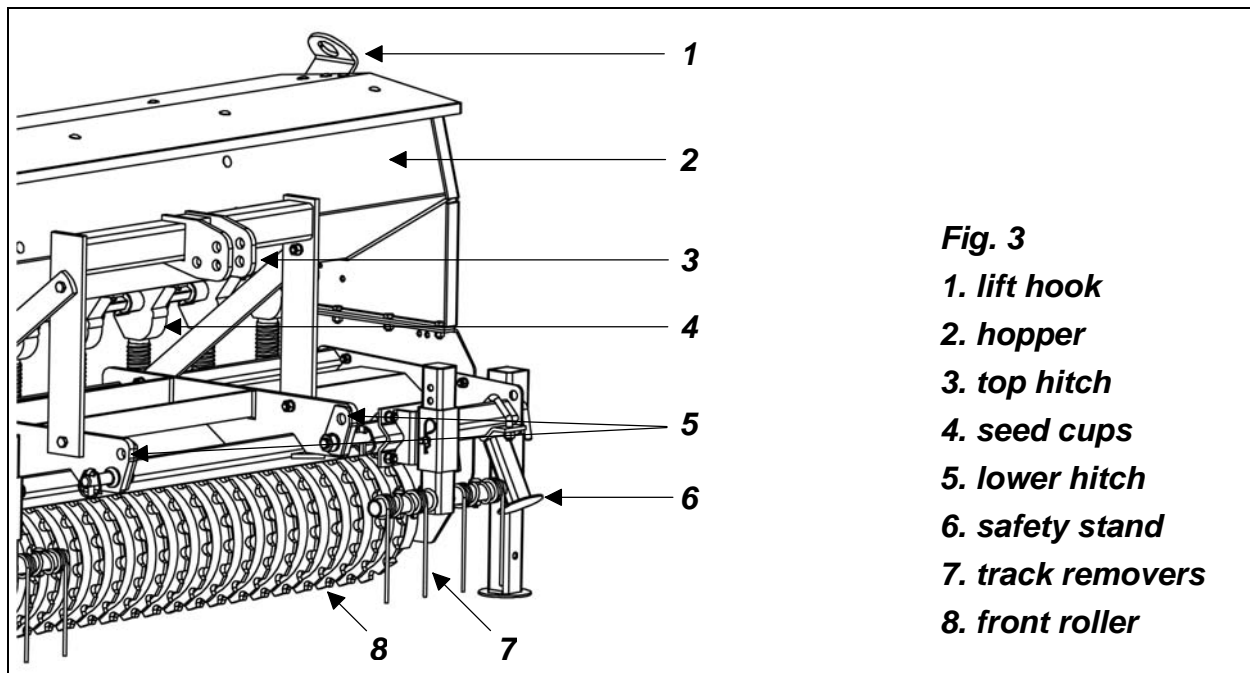

To attach the implement to the tractor do the following:  
 Back the tractor up to the Seed-Rite in order to slip the tractor hitch arms over the hitch pins bolted to the frame. **Turn off the tractor engine.**

<sup>5</sup> See Table 5, page 23.

The lower hitch pins (**see fig. 3**) may be put in either of 2 positions (upper or lower) depending on the tractor. Optional hitch blocks are available for use on tractors with non standard three point hitches. Secure the two arms with the lynch pins. Tighten the tractor arms side movement with either the sway chains or blocks to limit side swing to 2"-3". Connect the top link, locking it in place with the top hitch pin. Adjust it so the Seed-Rite is as near parallel to the ground as possible. A 1° to 2° rearward tilt is acceptable (**see fig. 4**).

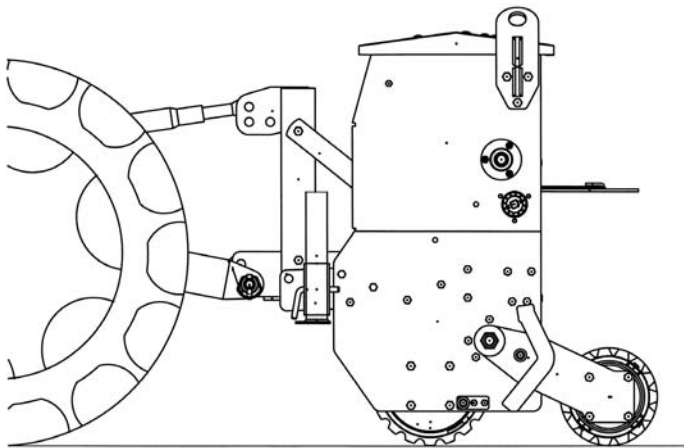

**Fig. 4**  
**Machine parallel to  
the ground.**

After use, the machine should be lowered and allowed to rest on the stand, and the rear roller should be blocked by inserting the two locking pins secured with hairpin cotters (**see fig. 5**).

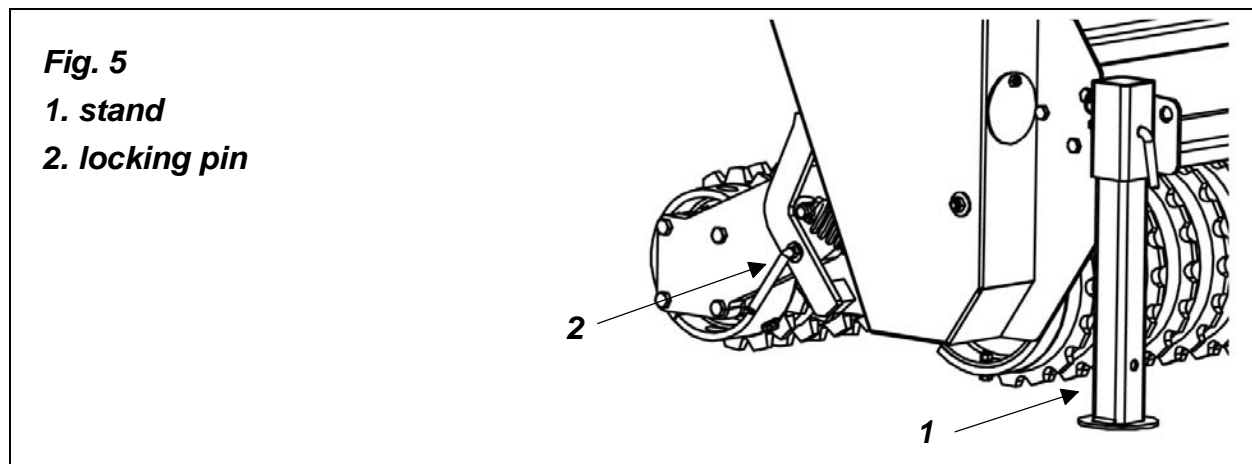

**Fig. 5**  
**1. stand**  
**2. locking pin**

### **3.05 - General Instructions for Use**

After you have read the Operator's Manual, have gone through the Pre-Operational Checklist and have correctly connected the Seed-Rite to the three-point hitch of the tractor, simply fill the hopper with seed, adjust the required calibration and distribution and you are ready to begin work.

Seed distribution is achieved from the forward motion of the tractor. As the front roller of the Seed-Rite moves forward, the movement of the front roller is transmitted by chains through a series of gears, to the seed cups which control the release of seed from the hopper. This allows for the seed to be sown constantly and in proportion to the distance covered by the tractor without being affected by its speed.

If the area to be seeded has already been tilled, then the front roller will level the soil to provide a better seed bed. If, on the other hand, the land has not been prepared in any way, the roller will break up the crust, splitting the largest clods, burying the smaller stones and basically preparing a no-till seed bed.

The seed is distributed with precision and in a predetermined manner in the area between the two rotors. The rear roller then incorporates the seed into the soil to improve germination.

Avoid seeding when it is raining or when the soil is too wet.

Before beginning seeding, make sure that the rear roller locking pins have been removed (**see fig. 5**). Also remove any obstacles present on the ground, particularly large stones.

Slowly lower the three point hitch and the seeder to the ground. Proceed slowly until you have become familiar with the machine. For better results, select a tractor speed between 3 to 5 mph. As you approach the end of a seeding lane, stop the tractor and raise the Seed-Rite from the ground. With the machine raised, turn the tractor and align it ready for the next passage. With experience, your ability to seed correctly will improve.

### 3.06 - Hopper Adjustment

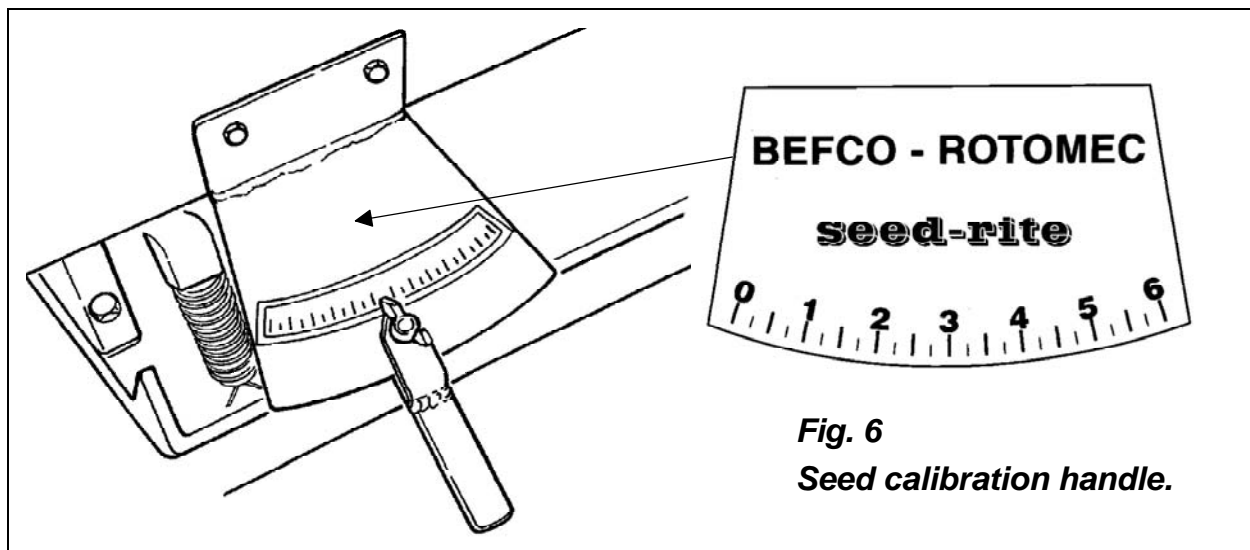

**Fig. 6**  
**Seed calibration handle.**

The Seed-Rite hopper holds 6.7 cu. ft. The hopper runs the entire width of the machine and has a continuously rotating ground driven agitator to breakup clods and ensure free flow through the distribution system. On the bottom of the hopper there are 10

rectangular slots to allow material passage. The **seed cups** mounted under the hopper, which are made entirely of non-corrosive material (nylon and fiberglass), contain an internal gear that rotates inside a housing. A **calibration handle** located on the rear left hand side of the hopper regulates how far to insert the gear inside the housing. The position of the handle, which has a scale from 0 to 6, determines the amount of seed distributed (**see fig. 6**). The seed cups are a force feed system driven by the roller.

The material is held inside the groove of the gear until the groove rotates to the opening at the bottom of the hopper. This rotation is driven by the roller as it moves along the ground. When the handle is in position "0" the gear is completely outside the seed cup and no seed is distributed. With the handle in position "6" the gear is totally inside the cup and distributes at its maximum potential (**see fig. 6**).

A secondary regulation is the lever located on the side of each cup housing. This controls the position of the cleanout gate (top, middle, and bottom). Its position is determined by the size and shape of the material being dispersed (**see fig. 7**).

The top position is for the smaller seeds, middle for the medium sized seed and bottom for larger seeds. Attached to the bottom of each cup is flexible tubing that the material flows through. As the material exits, it hits a split ring which divides the flow until it hits a splash pan and uniformly spreads over the entire working width of the Seed-Rite.

The hopper is ground driven by the roller which comes with two separate chains with automatic chain tensioners.

Although in essence a broadcast seeder, the Seed-Rite has all the technology to ensure a precise calibrated flow. Being ground driven, the disbursement of the material in the hopper is totally independent from the ground speed. This is regulated solely by the regulation levers of the seed cups and hopper.

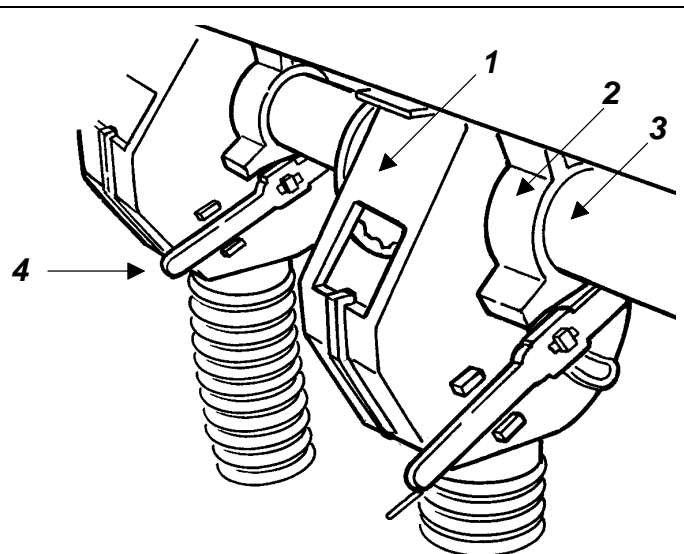

**Fig. 7**

1. **seed cup**
2. **gear support**
3. **drive shaft bushing**
4. **seed cup regulation lever**

### 3.07 - Seed (or Fertilizer) Hopper Calibration

There are two adjustments to be made to calibrate the Seed-Rite hoppers:

1. The amount of gear inside the seed cup housing.
2. The position of the cleanout gate of each individual seed cup.

This system allows use of a wide variety of seeds.

**The output of seed differs greatly depending on their size, density, dampness, and shape.** Other output factors depend on the conditions in which the machine is operating such as, in slick conditions where the roller may slip.

**Table 1** lists the distribution rate in pounds per acre for various seeds that may be used in the Seed-Rite.

Keep in mind that the hopper and seed cup openings measure in volume and not in weight. Due to the many variables, the distribution rate, when using **Table 1**, may not be always accurate. Only a test run will help determine if the desired amount of seed is being spread.

**TABLE 1 - AMOUNT OF SEED DISTRIBUTED IN LB/ACRE**

Seed type	Calibration handle position											
	0.5	1	1.5	2	2.5	3	3.5	4	4.5	5	5.5	6
Bentgrass	34	71	98	124	156	182	202	230	251	268	290	306
Kentucky bluegrass	18	43	61	81	105	122	138	160	178	195	213	223
Annual ryegrass	19	54	79	106	140	166	193	228	254	280	315	341
Perennial ryegrass	27	64	92	120	158	187	215	253	281	309	347	375
Fescue fine blade turf type	16	43	63	83	109	128	149	176	196	215	241	262
Fescue K-31	4	30	52	71	95	114	134	158	176	195	206	210
White clover	54	123	176	228	297	350	401	471	523	575	645	697
Red clover	51	110	151	194	250	291	334	389	432	474	530	572
Buffalo grass	0	25	43	63	90	109	131	155	176	195	217	224
Bermuda (hulled)	38	87	118	150	193	224	257	300	330	363	406	438
Western wheat grass	7	24	36	48	64	76	89	105	117	130	145	158
Crested wheat grass	14	28	39	48	63	73	84	98	108	119	132	142
Weeping love grass	68	122	163	200	250	287	325	375	411	448	498	537
Sand love grass	54	103	139	187	223	259	295	344	380	416	464	500
Alfalfa	43	110	161	213	280	330	382	450	500	552	618	670
Vetch	44	96	140	174	225	265	303	354	393	432	484	523

Use **Table 2 and 3** to determine if the rate you are getting is correct.

There are two ways of setting the calibration on your Seed-Rite:

1. With the machine stopped and raised, or
2. With the machine attached to the tractor and working.



**TABLE 2 - WORKING SURFACE**

<b>SRT-074</b>
1 front roller revolution = 17.44 sq. ft.
2498 front roller revolutions = 1 acre
57 front roller revolutions = 1000 sq. ft.

To set the calibration with the machine stopped, do the following:

1. Support the machine securely, but in a way to allow the roller to turn freely.
2. Fill the hopper with the seed or fertilizer you intend to spread.
3. Make sure the seed cups are not plugged with leaves, grass or other obstacles and that the seed cup regulation levers are all adjusted to the same opening position.
4. Remove the seed tubes from the lower bar and attach bags to the ends to allow the material to be collected.
5. Move the calibration handle located in the rear of the hopper to a position between 0.5 and 6 (**see fig. 6**).
6. Turn the front roller by hand in complete turns for a minimum of 20 turns. The greater the number of turns the more accurate the measurement will be.
7. Gather up and weigh all the material distributed in the bags. Divide this by the number of turns the roller made. This will give the amount of material dispersed per turn of the roller.
8. Each roller revolution, on the SRT-074, corresponds to a surface area of 17.44 square feet, therefore 57 revolutions equal to 1,000 square feet and 2,498 roller revolutions equal to 1 acre. To obtain the amount of seed spread per acre, multiply the quantity obtained with each revolution by 2,498 (**see Table 2**).
9. If the results do not correspond to the desired amount which needs to be distributed, adjust the calibration handle accordingly.

To calibrate the Seed-Rite while it is working, do the following:

1. Measure out a predetermined distance on the ground (for example 200 linear feet), keeping in mind that the further the distance, the more precise the measurement.
2. Fill the hopper with the seed you intend to spread.
3. Make sure the seed cups are not plugged with leaves, grass or other obstacles and that the seed cup regulation levers are all adjusted to the same opening position.
4. Remove the seed tubes from the lower bar and attach bags to the ends to allow the material to be collected.
5. Move the calibration handle located in the rear of the hopper to a position between 0.5 and 6.
6. Drive the tractor forward pulling the machine along the predetermined distance. It is important for the roller to remain on the ground at all times and to roll continuously.
7. Collect all material distributed and weigh.
8. Using **Table 3** determine the amount of material distributed. **Example: If the distance traveled is 100 ft. and 0.1 lb. of material is collected, then 6.2 lb. per acre of material is being distributed.**
9. If the results do not correspond to the amount that needs to be distributed, adjust the calibration handle accordingly.

**TABLE 3 - AMOUNT OF MATERIAL DISTRIBUTED IN LB/ACRE**

Lb. collected all seed cups	Distance traveled in feet									
	100	200	300	400	500	600	700	800	900	1,000
0.1	6.2	3.1	2.1	1.5	1.3	1.0	0.8	0.7	0.6	0.5
0.5	30.7	15.4	10.3	7.7	6.2	5.1	4.4	3.8	3.4	3.0
1	61.6	30.8	20.4	15.4	12.3	10.3	8.8	7.7	6.8	6.2
1.5	123.2	61.6	41.1	30.8	24.6	20.4	17.6	15.4	13.7	12.3
2	184.7	92.3	61.6	46.2	37.0	30.8	26.4	23.1	20.5	18.5
2.5	246.3	123.1	82.1	61.6	49.3	41.1	35.2	30.8	27.4	24.6
3	307.9	153.9	102.6	77.0	61.6	51.3	44.0	38.5	34.2	30.8
3.5	369.5	184.7	123.1	92.3	73.9	61.6	52.8	46.2	41.1	37.0
4	431.1	215.5	143.7	107.8	86.3	71.9	61.6	53.8	47.9	43.1
4.5	492.6	246.3	164.2	123.1	98.5	82.1	70.4	61.6	54.7	49.3
5	554.2	277.1	184.7	138.6	110.8	92.3	79.2	69.3	61.6	55.4
5.5	615.8	307.9	205.3	153.9	123.1	102.6	87.9	77.0	68.4	61.6
6	677.3	338.7	225.8	169.4	135.4	112.9	96.8	84.6	75.3	67.8
6.5	738.9	369.5	246.3	184.7	147.8	123.1	105.5	92.3	82.1	73.9
7	800.5	400.3	266.9	200.1	160.1	133.4	114.4	100.1	88.9	80.1
7.5	862.1	431.1	287.3	215.5	172.4	143.7	123.1	107.8	95.8	86.3
8	923.7	461.8	307.9	230.9	184.7	153.9	132.0	115.4	102.6	92.3
8.5	985.2	492.6	328.4	246.3	197.1	164.2	140.7	123.1	109.5	98.5
9	1,046.8	523.4	348.9	261.7	209.4	174.5	149.6	130.9	116.3	104.6
9.5	1,108.4	554.2	369.5	277.1	221.7	184.7	158.3	138.6	123.1	110.8
10	1,169.9	585.0	390.0	292.5	234.0	195.0	167.1	146.3	130.0	117.0

### 3.08 - Tickler Tine Bar (Option)

As an option the Seed-Rite can be furnished with two rear roller side extensions that include two rows of tickler tines mounted between the roller arms. These tines work as a rake to help cover grass seed for ideal germination conditions. The tines are raised and lowered automatically as the roller follows the contour of the ground.

The rear roller (see fig. 8) serves the following purposes:

1. Leveling the ground.
2. Compacting which results in helping bury the material that is distributed. The roller rings help push seed into soil which greatly speeds up and improves germination.

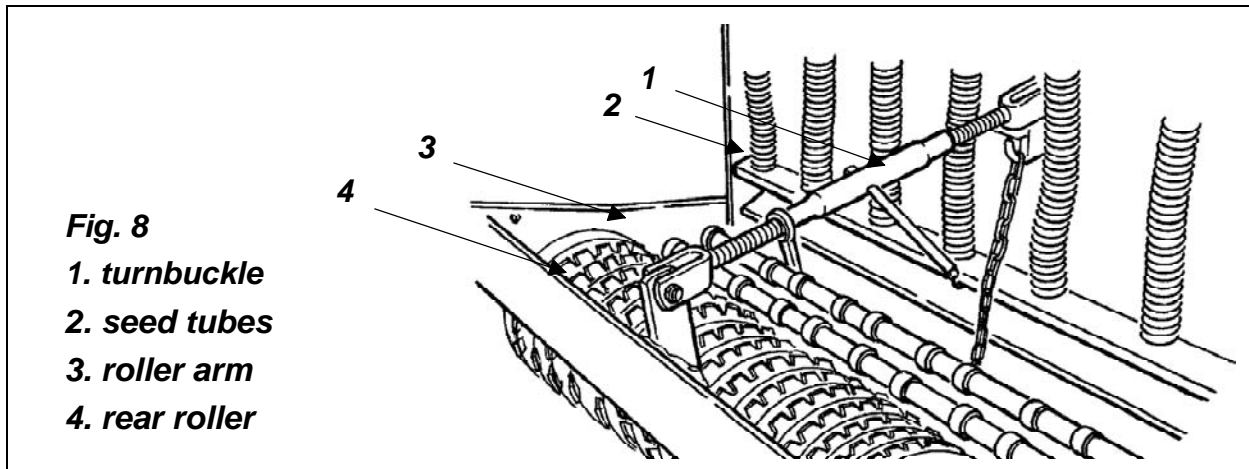

**Fig. 8**  
**1. turnbuckle**  
**2. seed tubes**  
**3. roller arm**  
**4. rear roller**

The tines can be adjusted by changing the position of the tine holder on the roller arms. The roller arms have two set positions to increase or decrease the tickler tine pressure. When the tine holder is positioned in the lower hole the pressure is increased, using the top hole decreases the pressure (**see fig. 9**). This also enables you to maintain a consistent pressure and angle as the tines wear. Always be sure both the right side and the left side are in the same holes.

The bars can be lifted completely up out of the way if the tickler tines are not to be used.

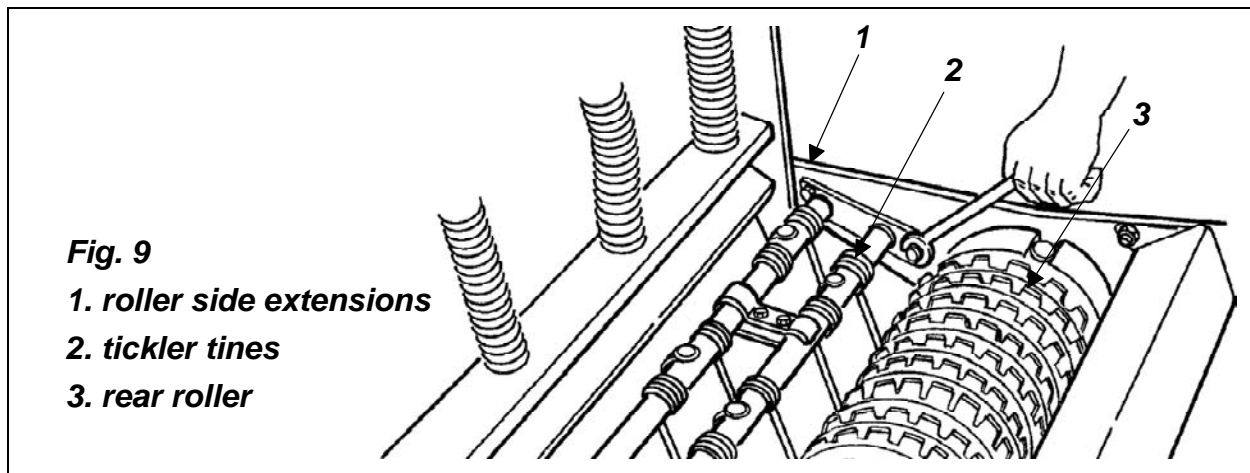

**Fig. 9**

1. roller side extensions
2. tickler tines
3. rear roller

### 3.09 - Start Up



**DANGER:** Never allow anyone around the Seed-Rite when it is in operation.



**CAUTION:** Before starting work, clear the area of any obstacles or foreign objects and make sure that the rear roller locking pins have been removed (see fig. 5).

Start out with the tractor in the lowest gear, increase gears slowly if necessary.

**Avoid working in reverse.**

Before beginning work always remember that the operator is responsible for:

1. Safe and correct operation of the tractor and Seed-Rite.
2. Learning and following precise, safe operating procedures for both the tractor and the Seed-Rite.
3. Ensuring all maintenance and lubrication has been performed on the Seed-Rite.
4. Having read and understood all safety aspects for the Seed-Rite in the operator's manual.
5. Having read and understood all safety decals on the Seed-Rite.

6. Checking that there are no wires, weeds, grass or other objects wrapped around the rollers.
7. Checking to see if front weights need to be added to the tractor in order to maintain balance.
8. Checking the tractor tires for the proper pressure in accordance to the tractor operator's manual.
9. Checking that all shielding is on the machine and securely in place.
10. Making sure the proper attire is worn. Avoiding loose fitting clothing which can become entangled. Wearing sturdy, tough-soled work shoes and protective equipment for eyes, hands, ears and head. Never operate tractor or implement barefoot, or wearing sandals or sneakers.
11. Checking area for stones, branches and other debris that might be thrown.
12. Ensuring proper lighting is available, sunlight or good artificial lighting.



**DANGER: Never use the machine without first assuring all protective devices are properly installed.**

### **3.10 - Test Run**

After the first 200-300 feet it is important to stop and raise the machine. Lower the machine, turn off the tractor engine and remove the key.

At this point make sure the Seed-Rite is performing correctly. Check for loose bolts or nuts.

### **3.11 - Working Speed**

Ground speed is determined by the soil condition and tractor power. Simple experimentation will soon determine the best speed for the desired results, usually 3 to 5 mph.

### **3.12 - Headland Procedure**

When the headland is reached, it is important that the following be observed:

1. Raise the machine from the ground.
2. Turn the tractor facing the new desired direction of travel.
3. Begin working again.

**NOTE: Best practice dictates that the machine be lifted no more than just enough to clear the ground.**

### 3.13 - Uneven Terrain



**DANGER:** Be careful when operating tractor and machine over uneven ground to avoid rollover.

The following precautions should always be observed when working on uneven terrain:

1. In extremely uneven terrain rear wheel weights, front tractor weights, and/or tire ballast should be used to improve stability.
2. Observe the type of terrain and develop a safe working pattern.
3. Operate the implement up and down steep slopes, not across slopes, to prevent the tractor from tipping. Avoid sudden stops and starts, and slow down before changing directions on a slope.
4. Pass diagonally through sharp dips and avoid sharp drops to prevent hanging up the tractor and implement.
5. Slow down on sharp turns and slopes to prevent tipping or loss of control.
6. Watch for holes, roots or other hidden objects. Do not use near the edge of a gully, ditch or stream bank.

### 3.14 - Transporting



**CAUTION:** All operations of transport are to be done without the Seed-Rite working and respecting all local traffic rules and regulations.

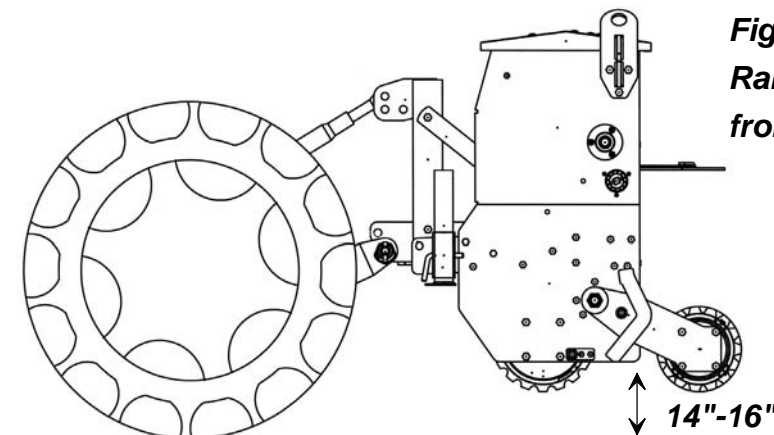







*Fig. 10*  
*Raise the machine 14" to 16"*  
*from the ground during transport.*

During transport or when the machine is lifted from the ground, it is advisable to adjust the tractor lift arms in order to be able to raise the machine 14" to 16" from the ground (see fig. 10).

**Before transporting:**

1. Always select a safe ground speed that is appropriate for the terrain.
2. Beware of traffic on public roads. Install a SMV (Slow Moving Vehicle) sign when traveling on roads or streets. Comply with all federal, state and local laws.
3. Reduce ground speed when turning and take care that the implement does not strike obstacles such as trees, fences or buildings.
4. Raise the implement in the transport position. The implement should not be lifted over 14" to 16" from the ground.

**TABLE 4 - BOLT AND NUT TORQUE SPECIFICATIONS**

Metric (ISO) treaded bolts head marking							Inch (SAE) treaded bolts head marking								
	Class 5.8		Class 8.8		Class 10.9			Grade 2		Grade 5		Grade 8			
Bolt size mm	Thread mm	N.m	ft-lb	N.m	ft-lb	N.m	ft-lb	Bolt size inch	Thread inch tpi	N.m	ft-lb	N.m	ft-lb	N.m	ft-lb
M5	0.8	4	3	6	4	9	7	1/4"	20	7	5	11	8	16	12
M6	1	6	4	10	7	15	11	1/4"	28	8	6	13	10	19	14
M8	1.25	16	12	25	18	36	27	5/16"	18	15	11	24	17	33	25
M8	1	17	13	26	19	38	28	5/16"	24	17	13	26	19	37	27
M10	1.5	31	23	48	35	71	52	3/8"	16	27	20	42	31	59	44
M10	1.25	33	24	51	38	75	55	3/8"	24	31	23	47	35	67	49
M10	1	35	26	53	39	78	58	7/16"	14	43	32	67	49	95	70
M12	1.75	54	40	84	62	123	91	7/16"	20	48	36	75	55	106	78
M12	1.5	56	41	87	64	128	94	1/2"	13	66	48	102	75	144	106
M12	1.25	59	44	90	66	133	98	1/2"	20	75	55	115	85	163	120
M14	2	84	62	133	98	195	144	9/16"	12	95	70	147	109	208	154
M14	1.5	94	69	142	105	209	154	9/16"	18	106	79	164	121	232	171
M16	2	131	97	206	152	302	223	5/8"	11	132	97	203	150	287	212
M16	1.5	141	104	218	161	320	236	5/8"	18	149	110	230	170	325	240
M18	2.5	181	133	295	218	421	310	3/4"	10	233	172	361	266	509	376
M18	2	196	145	311	229	443	327	3/4"	16	261	192	403	297	569	420
M18	1.5	203	150	327	241	465	343	7/8"	9	226	167	582	430	822	606
M20	2.5	256	189	415	306	592	437	7/8"	14	249	184	642	473	906	668
M20	1.5	288	212	454	335	646	476	1"	8	339	250	873	644	1,232	909
M22	2.5	344	254	567	418	807	595	1"	12	371	273	955	704	1,348	995
M22	1.5	381	281	613	452	873	644	1-1/8"	7	480	354	1,077	794	1,746	1,288
M24	3	444	327	714	526	1,017	750	1-1/8"	12	539	397	1,208	891	1,958	1,445
M24	2	488	360	769	567	1,095	808	1-1/4"	7	677	500	1,519	1,120	2,463	1,817
M27	3	656	484	1,050	774	1,496	1,103	1-1/4"	12	750	553	1,682	1,241	2,728	2,012
M27	2	719	530	1,119	825	1,594	1,176	1-3/8"	6	888	655	1,992	1,469	3,230	2,382
M30	3.5	906	668	1,420	1,047	2,033	1,499	1-3/8"	12	1,011	746	2,268	1,673	3,677	2,712
M30	2	1,000	738	1,600	1,180	2,250	1,659	1-1/2"	6	1,179	869	2,643	1,949	4,286	3,161
M36	4	1,534	1,131	2,482	1,830	3,535	2,607	1-1/2"	12	1,326	978	2,974	2,194	4,823	3,557

When using lock washers with nuts, increase torque values by 5%.

**TABLE 5 - SEED-RITE - TECHNICAL FEATURES**

Seed-Rite for tractors with a category 1 three point hitch.							
Model	HP	Working width	Overall width	Weight lb.	Hopper capacity cu. ft.	# Seed cups	Chains
SRT-074	35-70	74"	80"	1,008	6.7	10	ASA 50

## 4 - MAINTENANCE



**DANGER: Stop engine, lock parking brake and remove key before performing any service or maintenance.**

**Never rely on the tractor lift system. Install blocks or stands under the implement deck to prevent it from falling.**

**Always use personal protection devices, such as glasses or gloves when performing maintenance.**

**Keep fingers out of slots to prevent injury.**

### 4.01 - Maintenance Safety



1. Good maintenance is your responsibility.
2. Keep service area clean and dry. Be sure electrical outlets and tools are properly grounded. Use adequate light for the job at hand.
3. Make sure there is plenty of ventilation. Never operate the engine of the towing vehicle in a closed building. The exhaust fumes may cause asphyxiation.
4. Make no repair or adjustments with the tractor engine running. Before working on the machine, shut off the engine, set the brakes, and remove the ignition key.
5. Be certain all moving parts on attachment have come to a complete stop before attempting to perform maintenance.
6. Never work under equipment unless it is blocked securely.
7. Never trust the tractor hydraulics alone to support the machine. Before repairing or adjusting, the machine should be lowered and allowed to rest on the supplied stand.
8. Always use personal protection devices such as eye, hand and hearing protectors, when performing any service or maintenance.
9. Periodically tighten all bolts, nuts and screws and check that all cotter pins are properly installed to ensure unit is in a safe condition.
10. When completing a maintenance or service function, make sure all safety shields and devices are installed before placing unit in service.
11. After servicing, be sure all tools, parts and service equipment are removed.
12. Never replace hex bolts with less than grade five bolts unless otherwise specified, i.e. shear bolts<sup>6</sup>.
13. Where replacement parts are necessary for periodic maintenance and servicing, genuine replacement parts must be used to restore your equipment to original specifications. The company will not claim responsibility for use of unapproved parts and/or accessories and other damages as a result of their use.

---

<sup>6</sup> Refer to Table 4 - Torque Specifications, page 23.



14. Unauthorized modifications to the machine may impair the function and/or safety of the machine and reduce its life. If equipment has been altered in any way from the original design, the manufacturer does not accept any liability for injury or warranty.

## 4.02 - Service

The following illustrations show lubrication points. The frequency of lubrication given is based on normal operating conditions. Severe or unusual conditions may require more frequent lubrication.

Use a good quality SAE multipurpose type grease for all locations shown. Be sure to clean fittings thoroughly before using grease gun. Immediately replace broken or missing fittings.

**Fig. 11 - Lubrication points**

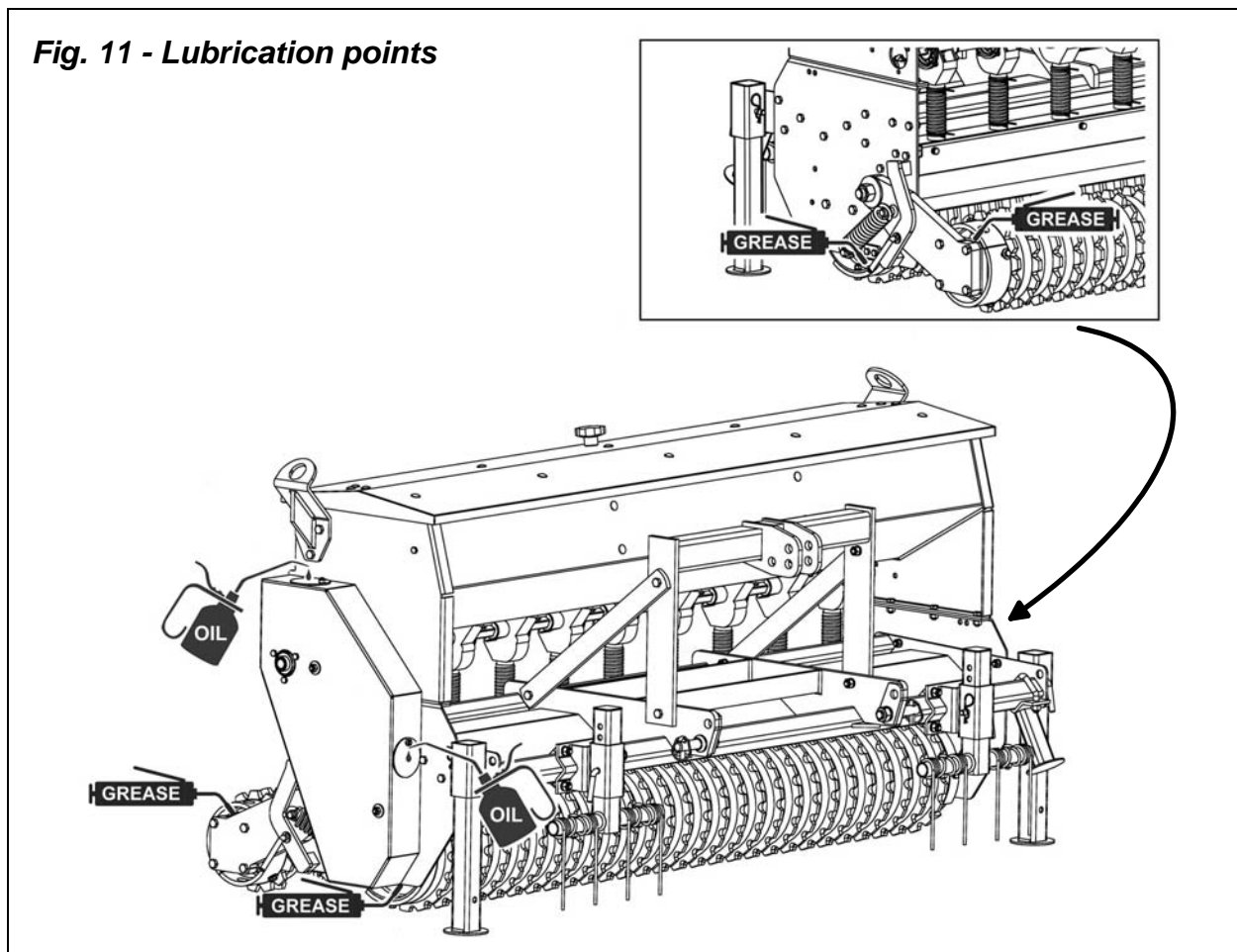

### Hourly or whenever an obstacle is hit:

1. Check machine condition.
2. Remove any wrapping (stalks, weeds, trash, etc.) from rollers, especially from around bearing supports on the roller ends.

**Every 8 hours:**

1. **Grease the roller supports (see fig. 11).** Apply two or three shots of grease to the roller bearings on both front and rear rollers.
2. Whenever the hopper is used for fertilizer spreading it is extremely important to carefully clean out the hopper and wash the machine with hot water. Do not forget that fertilizer is highly corrosive and should not be left in the hopper any longer than necessary.

**Every 25 hours:**

**Check hardware tightness;** vibration can loosen bolts<sup>7</sup>. Check tightness of the hardware periodically.

**Every 50 hours:**

Inspect all the drive chains from the access panels and make sure they are well lubricated (**see fig. 11**).

---

<sup>7</sup> See Table 4, page 23.

## 5 - REPAIR PROCEDURES



**CAUTION:** All repair procedures must be done by authorized dealerships. It is not recommended that untrained individuals perform any repair work. The following operations are detailed for qualified personnel only.

### 5.01 - Chain Case and Chain Replacement

To remove the chain do the following:

1. Remove the two nuts that hold the chain case cover to the frame.
2. Loosen the two set screws that hold the flange bearing to the pinion auger shaft (**see #1, fig. 12**).
3. Remove the chain case cover.
4. Release the automatic chain tensioner springs (**see #6, fig. 12**).
5. Remove the nut that holds the lower idler sprocket (**see #7, fig. 12**).
6. Remove the nut that holds the central double sprocket (**see #4, fig. 12**).
7. Loosen the set screws that hold the roller sprocket (**see #5, fig. 12**).
8. Remove the lower idler sprocket.
9. Reaching behind the right side panel, remove the bolt that holds the central double sprocket.
10. Remove both chains.

To replace the chains do the following:

1. Loosely place top chain ASA 50x66 (**see #2, fig. 12**) on top sprocket and lower chain ASA 50x50 (**see #3, fig. 12**) on roller sprocket.
2. Reaching behind the right side panel, insert the bolt that holds the central double sprocket (**see #4, fig. 12**) and on the opposite side of the right side panel insert the bushing.
3. Place chains on central double sprocket ensuring top chain is placed on the Z15 side (inner side) and bottom chain on the Z30 side (outer side) of the sprocket.
4. Assemble the chain-sprocket assembly to the bolt and slide it in until it is flush to the bushing previously inserted.
5. Ensure proper sprocket alignment, then tighten set screws that hold the roller sprocket (**see #5, fig. 12**).
6. Assemble the lower idler sprocket (**see #7, fig. 12**) to the chain tensioner support and tighten the nut.
7. Tighten the nut that holds the central double sprocket.
8. Attach top and bottom chain tensioner springs (**see #6, fig. 12**).
9. Replace the chain case cover and tighten the two set screws that hold the flange bearing to the pinion auger shaft (**see #1, fig. 12**).
10. Tighten the nuts that hold the chain case cover to the frame.

**Fig. 12 - Chain assembly**

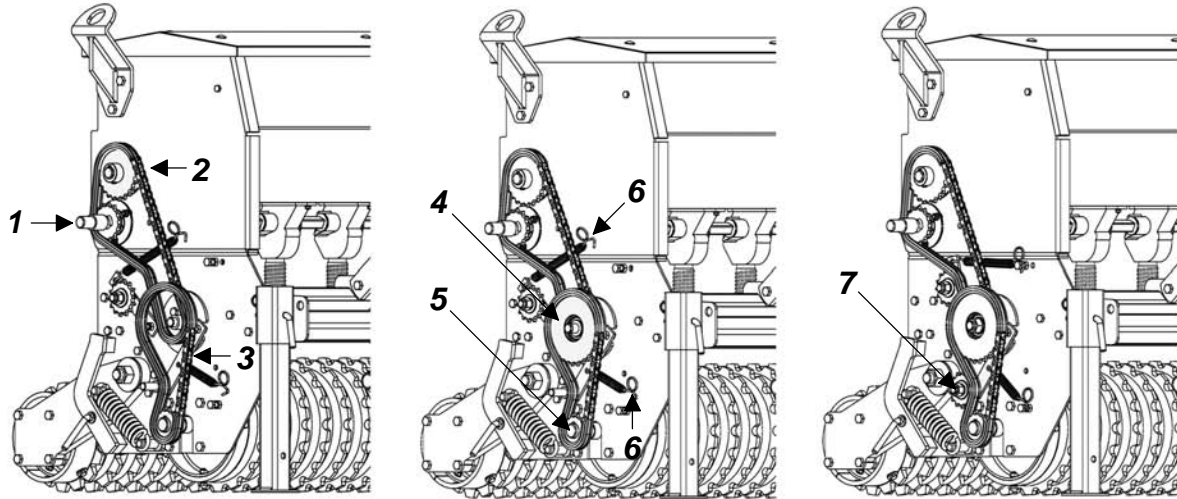

**A. Loosely place both chains on top and bottom sprockets, insert bushing on bolt that holds the central double sprocket.**

**B. Place chains on central double sprocket and then assemble to the bolt, ensure sprockets are aligned then tighten roller sprocket set screws.**

**C. Insert idler sprocket, tighten all sprocket nuts and attach both chain tensioner springs.**

### 5.02 - Front Roller Replacement

To remove the front roller proceed as follows:

1. Securely support the implement.
2. Remove the side transmission<sup>8</sup>.
3. Remove the four bolts on the right side panel and the four bolts on the left side panel that hold the front roller supports.
4. Slide the roller out.

### 5.03 - Suggested Spare Parts

It is suggested that the following spare parts be kept on hand at all times to prevent a minor problem from delaying work:

Description	Quantity
Front roller rings	5
Rear roller rings	5
Seed cups	3
Chains	1 set

<sup>8</sup> See Section 5.01 - Chain Case and Chain Replacement.

## 5.04 - Storage

After seasonal use it is important to perform the following for prolonged storage:

1. Lower the stand (**see fig. 5**) and remove the machine from the tractor.
2. Block the rear roller by inserting the two locking pins secured with hairpin cotters.
3. Wash the Seed-Rite carefully, especially inside the hopper.
4. Inspect the Seed-Rite and replace worn or damaged parts.
5. Tighten all hardware<sup>9</sup>.
6. Grease all areas indicated under maintenance.
7. Cover the Seed-Rite from the elements in order to have it in perfect condition for the start of the next season.



**WARNING:** Be sure to store the implement on a hard level surface and away from people especially children.

---

<sup>9</sup> See Table 4, page 23.

## 6 - TROUBLESHOOTING



**WARNING:** Be sure tractor engine is off, parking brake is locked, and key is removed before making any adjustments.

PROBLEM	POSSIBLE CAUSE	SOLUTION
Uneven seed distribution.	Seed cups might be obstructed. Ground speed too fast. Rollers not clean.	Check for plugging in seed cup. Reduce ground speed. Check for trash or mud buildup on rollers.
Actual seeding rate is different than desired.	Seed cups might be obstructed.	Seed treatment will affect seeding rate if the chemicals build up in seed cup. Unless cleaned regularly, this buildup can cause breakage of the seed cup shaft.
Seed cup sprocket locked up or twisted seed cup drive shaft.	Seed cups might be obstructed.	Check for foreign matter lodged in seed cup sprocket.
Rollers not turning freely.	Rollers not clean.	Check for trash or mud buildup on roller end.

## 7 - PRE-DELIVERY CHECKLIST

**To the dealer: Inspect the machine thoroughly after assembly to assure it is functioning properly before delivering it to the customer. The following checklist is a reminder of points to cover. Check off each item as it is found satisfactory or after proper adjustment is made.**

- Guards and shield properly fastened.
- Lubrication of grease fittings.
- All hardware properly tightened.
- All decals properly located and readable (**see fig. 2**).
- Overall condition (touch up scratches, clean and polish).
- Test run, check for excessive vibration or overheating of bearings.
- Operator's Manual.

**Review the Operator's Manual with the customer. Explain the following:**

- Warranty.
- Safe operation and service.
- Correct machine installation and operation.
- Daily and periodic lubrication, maintenance and inspections.
- Troubleshooting.
- Operational procedures and storage.
- Parts and service.
- Fill out the Pre-Delivery Checklist and Warranty Registration form.
- Give customer the Operator's Manual and encourage the customer to read the manual carefully.

**IMPORTANT: Warranty is not valid unless Pre-Delivery Checklist and Warranty Registration form in Operator's Manual is completed in detail and mailed to the Company.**

Model Number: \_\_\_\_\_

Serial Number: \_\_\_\_\_

Delivery Date: \_\_\_\_\_

Dealer's Signature: \_\_\_\_\_

## 8 - WARRANTY

BEFCO's responsibility will be limited to substitution of the acknowledged defective merchandise to the same place of delivery as the previous one was supplied.

### 1. LIMITED WARRANTY

BEFCO, Inc. herein referred to as the Company, warrants its machines and related accessories, hereafter referred to as the Machine, to be free from defects in material and workmanship, for a period of twelve (12) months from the date of invoice to the first registered owner; this limited warranty does not apply to common wear items and excludes belts, shear pins, oil, grease, tires, tubes, hydraulic hoses, knives and PTO shafts.

Labor will be reimbursed at \$40.00 per hour based on BEFCO's time schedule.

Cost of transport to the servicing dealer is the responsibility of the customer.

Warranty coverage shall not be transferable from the first owner to any subsequent owner.

### 2. DISCLAIMER OF ALL OTHER WARRANTIES AND REMEDIES

Neither the Company nor any company affiliated with the Company makes any warranties, representations or promises, expressed or implied, as to the quality, performance or application of its products other than those set forth herein and does not make any implied warranty of merchantability or fitness.

The only remedies the purchaser has in connection with the breach, or performance of any warranty on the Company's Machine are those set forth herein. In no event will the dealer, the Company, or any company affiliated with the Company, be liable for:

- a. Injuries or damages of any kind or nature, direct, consequential or contingent to person or property.
- b. Any expenses incurred by the owner to repair, replace or rework any allegedly defective item.
- c. Any loss, cost, forfeiture or damages (including loss of profits; loss of crops; loss because of delay in field operations; any expenses or loss incurred for labor, supplies, substitute machine rental; liabilities of the owner to its customers or third persons; and all other consequential damages, losses, liabilities or damages for any other reasons) whether direct or indirect, and whether or not resulting from or contributed to by the default or negligence of the Company, its agents, employees and subcontractors which might be claimed as a result of the use or failure of the equipment delivered.

The Company's liability based on this limited warranty or any other applicable laws shall be limited to replacement or refund of the purchase price of the product.

The limited warranty extended herein gives you specific rights and you may also have other rights which vary from state to state. Neither the dealer nor the Company personnel has the authority to make any representation or to modify the terms and limitations of this warranty in any way.



**Other than the limited warranty extended hereby there is no other expressed warranty in connection with the design, safety or use of any of the Company's products except as to title. All implied warranties are expressly disclaimed pursuant to the terms of this warranty.**

### **3. CUSTOM WORK**

If the Machine is used for commercial purposes such as custom work, the period warranted for the Machine is limited to six (6) months from the date of delivery to the first registered owner and does not cover any labor charges incurred.

### **4. RENTAL**

If the Machine is used for rental purposes the period warranted for the Machine is limited to thirty (30) days from the date of delivery to the first registered owner and does not cover any labor charges incurred.

### **5. REGISTRATION**

In order to qualify for coverage on this limited warranty, the product and name of the original purchaser must be registered with the Company by a completed Machine Pre-Delivery Checklist and Warranty Registration along with a copy of the dealer's invoice to the first registered owner to the Company within fourteen (14) days after the date of delivery to the original purchaser.

### **6. WARRANTY SERVICE**

Warranty Service must be performed by a dealer authorized by BEFCO. If the warranty service requested is approved, the owner shall pay only for labor beyond the rate allowed, for overtime labor, and for any mileage charge for transporting the equipment to and from the dealer's shop. It is assumed that the dealer has the appropriate general and special tools to service the Machine. Time required for replacement of knives, oil, grease and to remove excessive dirt from the Machine is not subject to reimbursement by the Company. The owner is required to clean the Machine before presenting it to the dealer for service work. The Machine must be delivered within thirty (30) days after failure date by the owner to the dealer to be eligible for warranty consideration.

### **7. UNAPPROVED SERVICE OR MODIFICATION**

All obligations of the Company under this limited warranty shall be terminated if:

- a. Proper service and operation instructions as outlined in the Operator's Manual and on the instruction sticker on the Machine, are not followed.
- b. The Machine is modified or altered in any way not approved by the Company.
- c. The Company does not receive a copy of the dealers invoice to the first registered owner within fourteen (14) days from the date of delivery.
- d. The Company has not been paid in full, by the dealer, for the Machine.

### **8. ACCIDENTS AND NORMAL MAINTENANCE**

This limited warranty covers defective material and workmanship. It does not cover depreciation or damage caused by normal wear, accidents, improper maintenance, improper protection or improper use. The costs of normal maintenance or repairs for accidents or improper use, and related labor will be borne by the owner.

### **9. REPLACEMENT PARTS**

BEFCO, Inc. warrants replacement parts to be free from defect in material and workmanship for a period of thirty (30) days from the date of delivery to the original purchaser.



# WARRANTY REGISTRATION

**BEFCO, Inc.**  
**P.O. Box 6036**  
**Rocky Mount, NC 27802-6036**

**Tel: (252) 977.9920 - Fax: (252) 977.9718**

Dealer _____ Acct. # _____	Retail Customer _____
Street _____ Country _____	Street _____
Town _____ State _____ Zip _____	Town _____ State _____ Zip _____
Date of delivery _____ Invoice # _____	Phone _____
Model # _____ Serial # _____	
<p>Pre-Delivery Checklist:</p> <p><input type="checkbox"/> Oil in gearbox.</p> <p><input type="checkbox"/> Greased fittings.</p> <p><input type="checkbox"/> Safety guards in place.</p> <p><input type="checkbox"/> All hardware tight.</p> <p><input type="checkbox"/> Bolts torqued correctly.</p> <p><input type="checkbox"/> Attached unit to tractor. Yes/No.</p> <p><input type="checkbox"/> Field adjusted. Yes/No.</p> <p><input type="checkbox"/> Test run. Dry/Infield.</p> <p><input type="checkbox"/> Safety decals.</p> <p><input type="checkbox"/> Operator's Manual.</p> <p>The machine described above, had been prepared for delivery according to the Pre-Delivery Checklist and the Customer has been instructed in its care and operation and the condition of warranty.</p>	<p>Tractor make: _____</p> <p>Model: _____; HP _____</p> <p>Type of operation: Private homeowner, Landscaping, Commercial maintenance, Golf Course, Municipality, Turf Farm, others: _____</p> <p>Approximate number of acres machine will be used on annually: _____</p> <p>I hereby acknowledge that:  I have received and accepted delivery of the machine described.  The equipment was checked thoroughly for loose or missing parts and has been adjusted in accordance with the Pre-Delivery Checklist.  I have read and understand the nature and extent of the warranty and understand clearly that there were and are no other representations of warranties either expressed or implied, made by anyone. I have been advised on proper operation, maintenance and lubrication procedure of this equipment.  I have been instructed on and do understand the application, limitation and capacities this equipment was designed and recommended for, all as described in the Operator's Manual and literature published by the Company.</p>
Inspected by: _____	
Date: _____	Date: _____
Dealer's Signature: _____	Customer's Signature: _____

**This registration along with a copy of the invoice must be sent to BEFCO, Inc. within 14 days of date of purchase.**

*Sender:*

*Fold here*

---

*Place stamp  
here*

**BEFCO, Inc.**

Warranty Department

P.O. Box 6036

Rocky Mount, NC 27802-6036

*Cut along this line*



# BEFCO®

## Parts Manual

### SEED-RITE

Primary full-width seed broadcaster

**SRT-074**

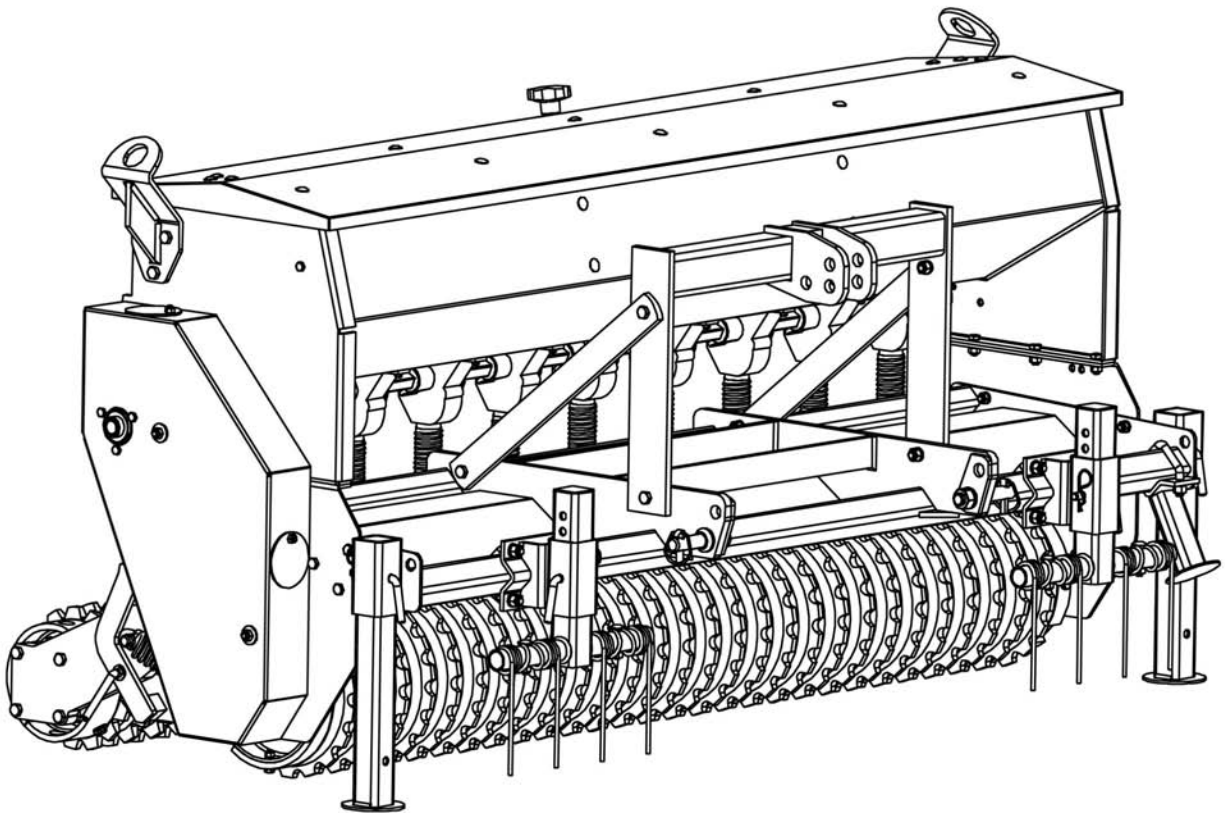

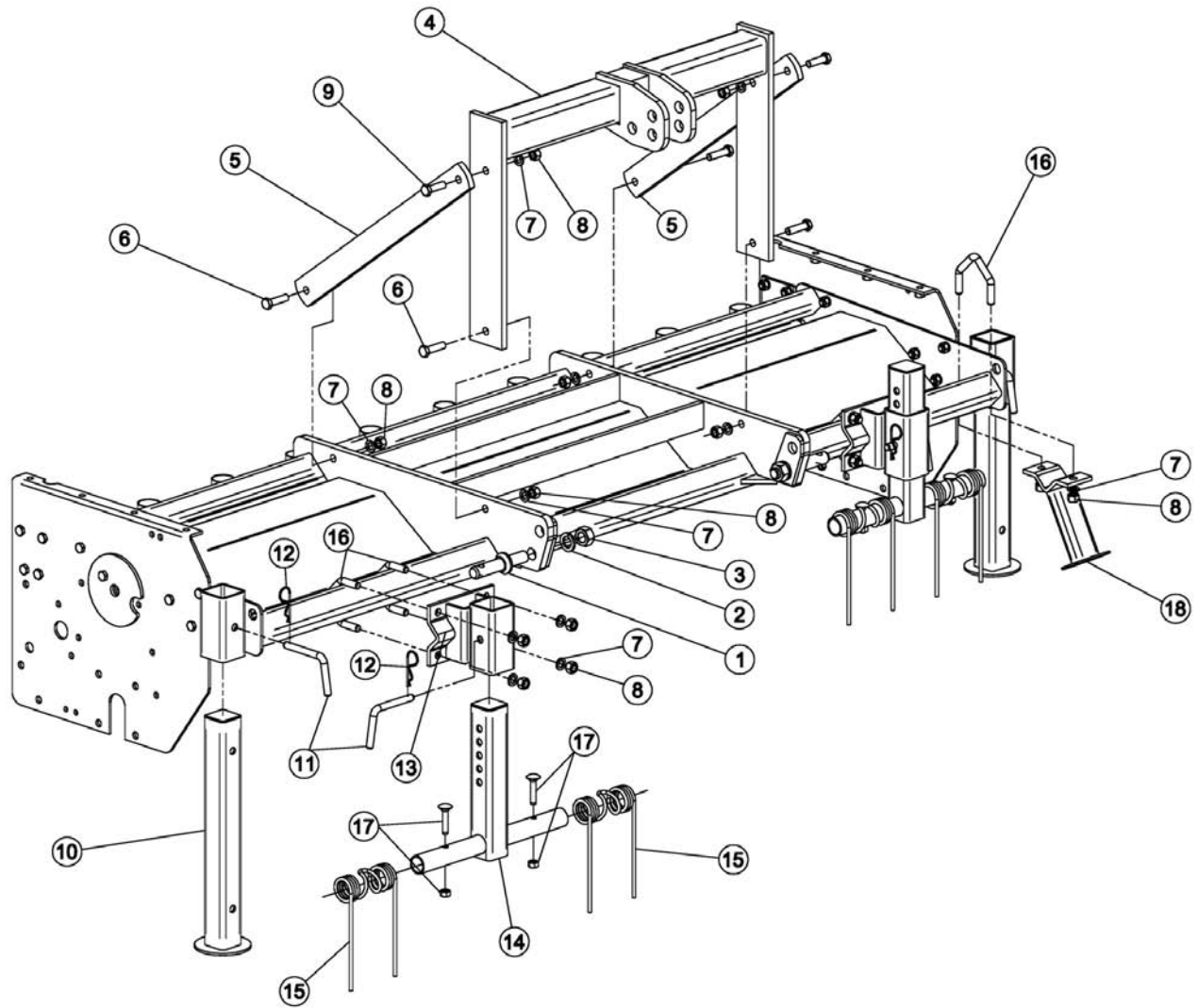

Ref.	Part #	Description	Qty.
1	000-5550	Hitch pin	2
2	000-5351	Washer lock Ø20 Z	2
3	000-5542	Nut HH M20-1.50 C6 MD Z	2
4	008-4772	Three point hitch	1
5	008-8560	Top hitch support	2
6	000-7716	Bolt HH M12-1.75x45 C8.8 Z F	4
7	000-1077	Washer lock Ø12 Z	16
8	000-3038	Nut HH M12-1.75 C6 TK Z	16
9	002-3265	Bolt HH M12-1.75x40 C8.8 Z F	2
10	008-8570	Stand	2
11	008-4619	Hitch pin	4
12	005-4422	Hairpin cotter Ø2.5 Z	4
13	008-8700	Hitch, front track remover	2
14	008-8710	Front track remover	2
15	004-6358	Spring, tickler tooth	4
16	001-1251	Bolt "V" M12-1.75 Z	5
17	004-6362	Bolt CR M10-1.50x50 C4.6 Z	4
18	008-8720	Safety stand	1

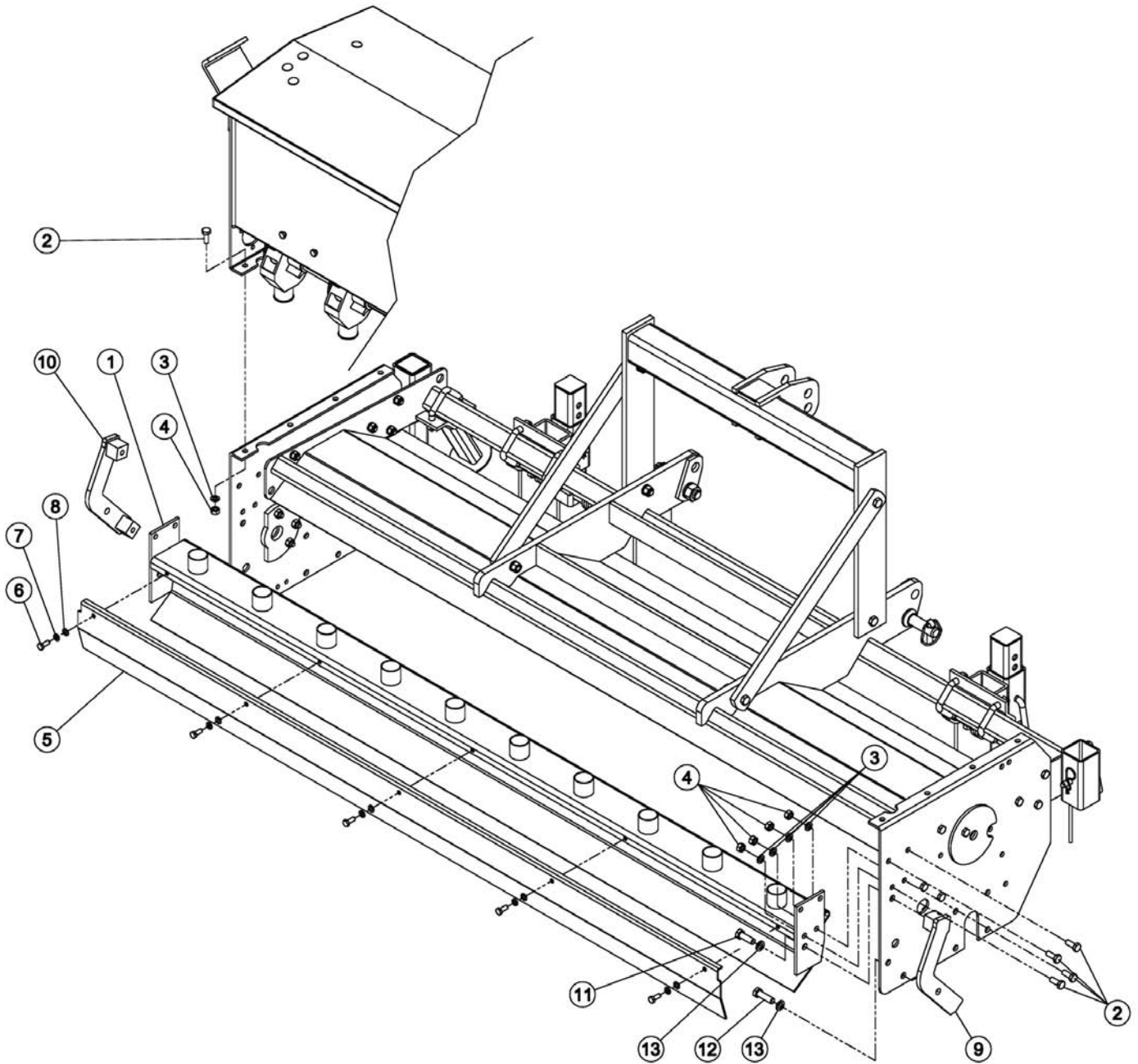



Ref.	Part #	Description	Qty.
1	048-8880	Discharge support SRT-074	1
2	003-3176	Bolt HH M10-1.50x25 C8.8 Z F	16
3	000-1280	Washer lock Ø10 Z	16
4	000-1279	Nut HH M10-1.50 C6 TK Z	16
5	048-8890	Wind guard	1
6	001-5012	Bolt HH M08-1.25x20 C8.8 Z F	5
7	000-3144	Washer lock Ø08 Z	5
8	001-5230	Washer flat Ø08 W	5
9	018-8633	Rear roller lock bracket, right	1
10	028-8633	Rear roller lock bracket, left	1
11	002-3265	Bolt HH M12-1.75x40 C8.8 Z F	2
12	000-7255	Bolt HH M12-1.75x35 C8.8 Z F	2
13	000-1077	Washer lock Ø12 Z	4

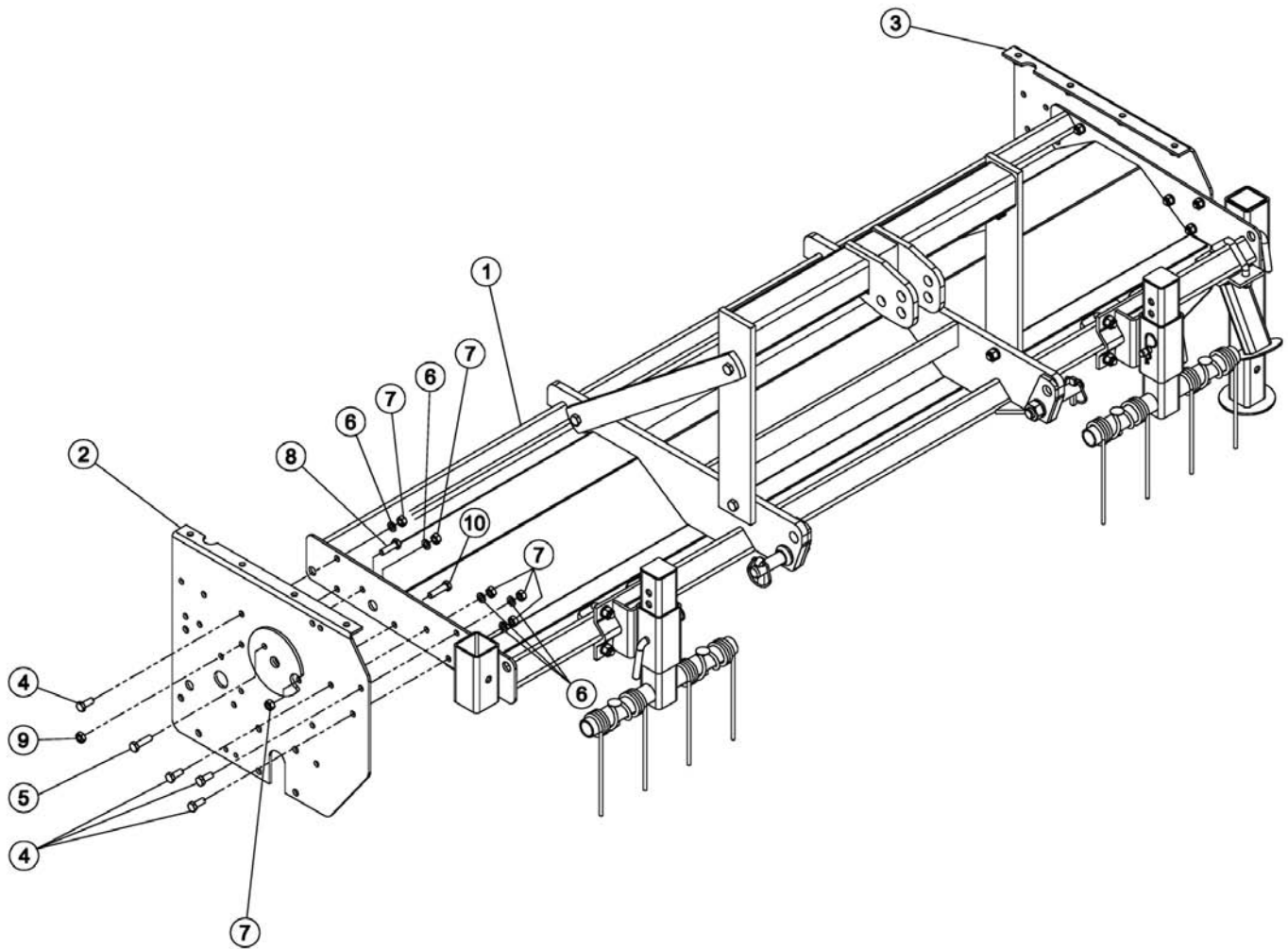

Ref.	Part #	Description	Qty.
1	048-8510	Frame SRT-074	1
2	008-8530	Right side panel	1
3	008-8540	Left side panel	1
4	003-3176	Bolt HH M10-1.50x25 C8.8 Z F	4
5	000-1278	Bolt HH M10-1.50x30 C8.8 Z F	1
6	000-1280	Washer lock Ø10 Z	5
7	000-1279	Nut HH M10-1.50 C6 TK Z	6
8	009-1281	Bolt HH M10-1.50x35 C8.8 Z F	1
9	009-0150	Nut HH M10-1.50 C6 MD Z	1
10	003-8614	Bolt HH M10-1.50x40 C8.8 Z F	1

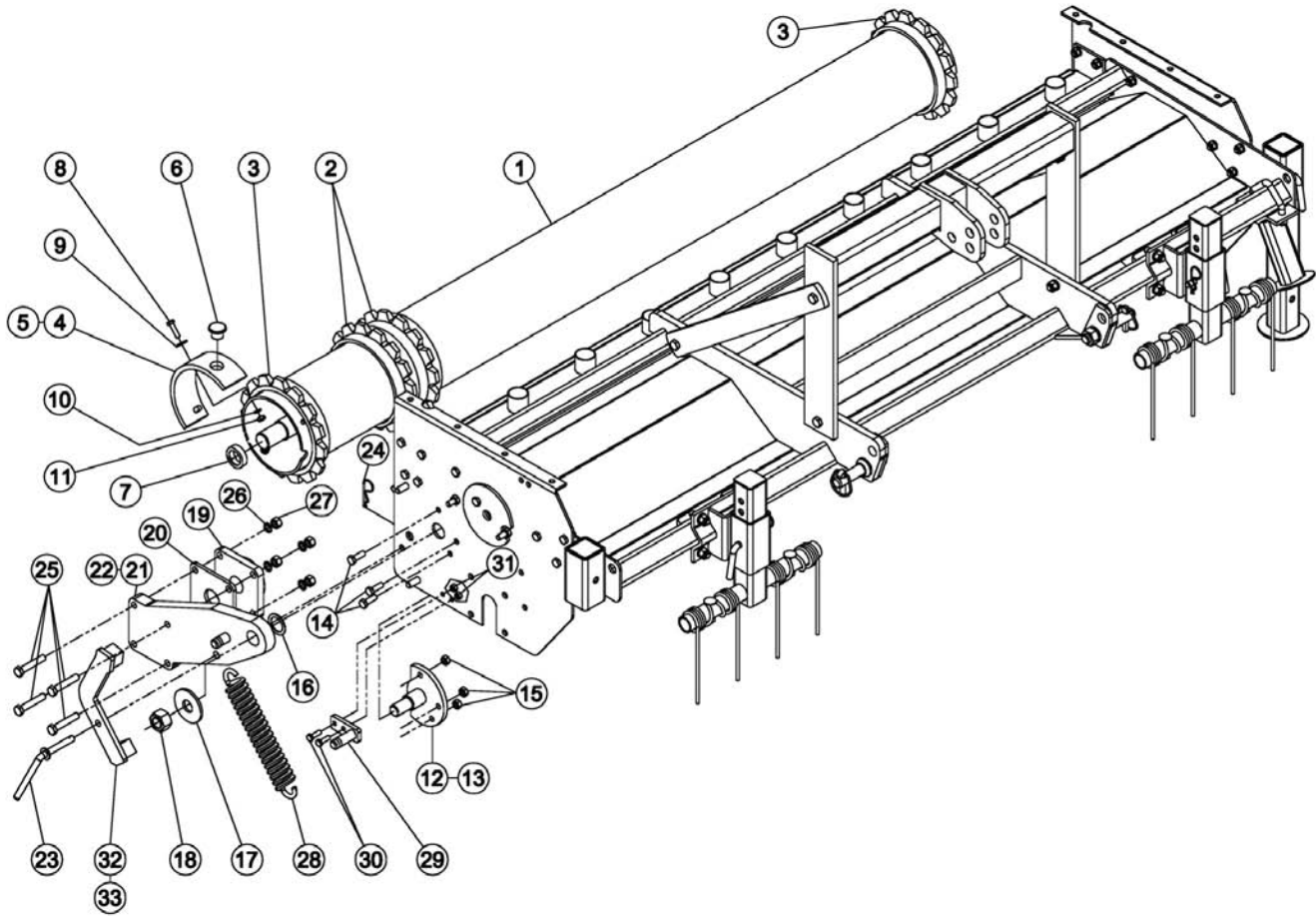

Ref.	Part #	Description	Qty.
1	048-8640	Rear roller SRT-074	1
2	014-6322	Corrugated roller ring, nylon-fiberglass	27
	008-8645	Corrugated roller ring, cast iron (option)	27
3	008-8649	Corrugated roller semi-ring, nylon-fiberglass	2
	008-8646	Corrugated roller semi-ring, cast iron (option)	2
4	008-8650	End ring with hole	2
5	008-8651	End ring without hole	2
6	008-8658	Plastic cap	2
7	008-8588	Spacer	2
8	004-6543	Bolt HH M08-1.25x30 C8.8 Z F	8
9	001-4514	Washer fender Ø08 Z	8
10	001-5230	Washer flat Ø08 W	8
11	001-1328	Nut PT M08-1.25 C6 TK Z	8
12	018-8605	Roller support shaft, right	1
13	028-8605	Roller support shaft, left	1
14	000-1278	Bolt HH M10-1.50x30 C8.8 Z F	6
15	001-4106	Nut ES M10-1.50 TK Z	6
16	004-4128	Shim Ø32x45x2	2
17	002-9536	Washer fender Ø24 Z	2
18	008-8616	Nut ES M24-3.00 C6 TK Z	2
19	004-6331	Support UCF 207 TF	2
20	008-8625	Spacer plate	2
21	018-8610	Roller arm, right	1
22	028-8610	Roller arm, left	1
23	011-8114	Locking pin	2
24	005-4422	Hairpin cotter Ø2.5 Z	2
25	003-4265	Bolt HH M12-1.75x65 C8.8 Z P	8
26	000-2265	Washer flat Ø12 W	8
27	003-0064	Nut PT M12-1.75 C6 TK Z	8
28	008-8624	Spring, roller arm	2
29	008-8620	Attachment plate, spring	2
30	009-1446	Bolt HH M08-1.25x25 C8.8 Z F	4
31	009-1384	Nut ES M08-1.25 TK Z	4
32	018-8633	Rear roller lock bracket, right	1
33	028-8633	Rear roller lock bracket, left	1

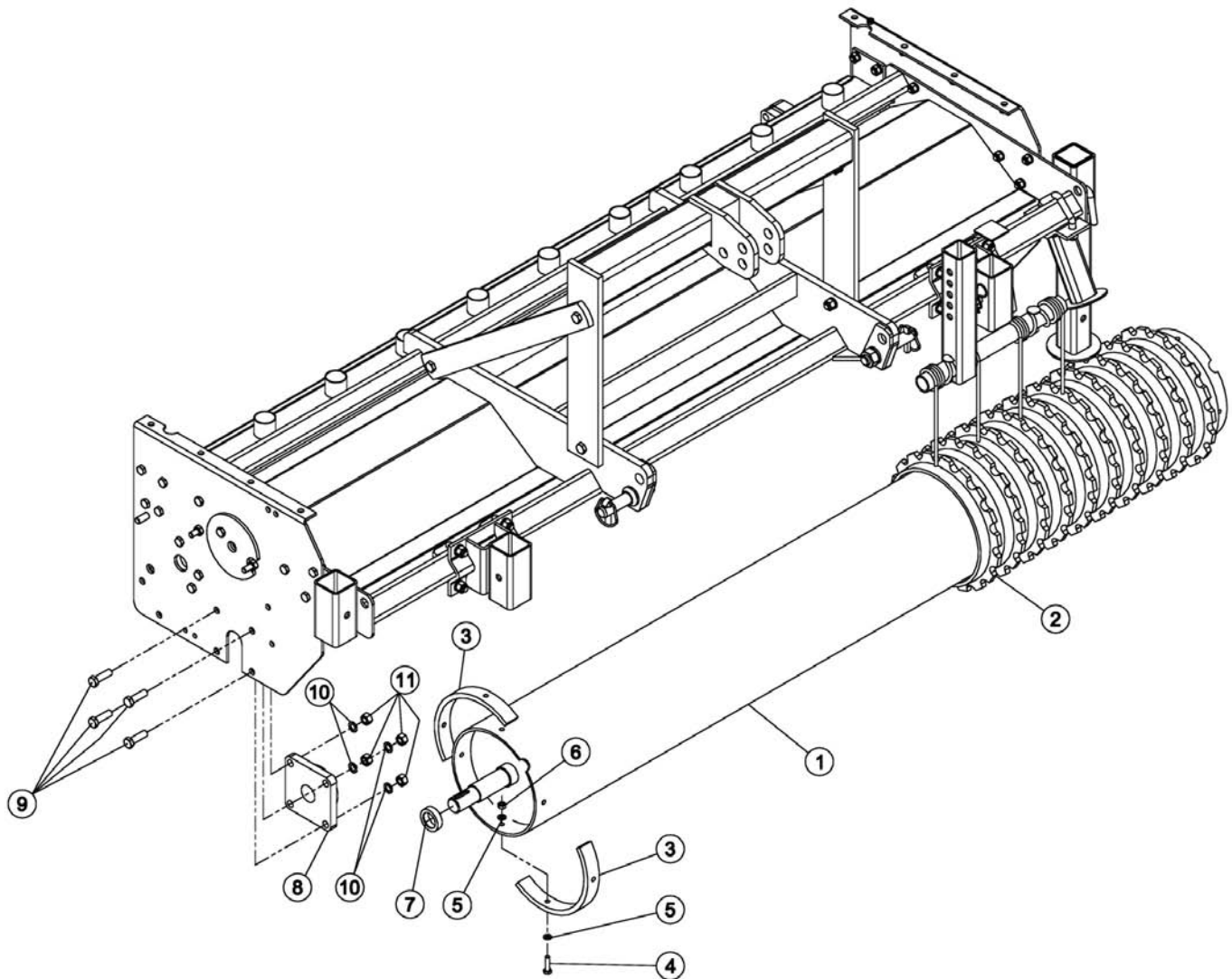

Ref.	Part #	Description	Qty.
1	048-8580	Front roller SRT-074	1
2	004-6322	Corrugated roller ring, nylon-fiberglass	28
	008-8589	Corrugated roller ring, cast iron (option)	28
3	008-4481	End ring	4
4	004-6543	Bolt HH M08-1.25x30 C8.8 Z F	8
5	001-5230	Washer flat Ø08 W	16
6	001-1328	Nut PT M08-1.25 C6 TK Z	8
7	008-8588	Spacer	2
8	004-6331	Support UCF 207 TF	2
9	002-3265	Bolt HH M12-1.75x40 C8.8 Z F	8
10	000-2265	Washer flat Ø12 W	8
11	003-0064	Nut PT M12-1.75 C6 TK Z	8

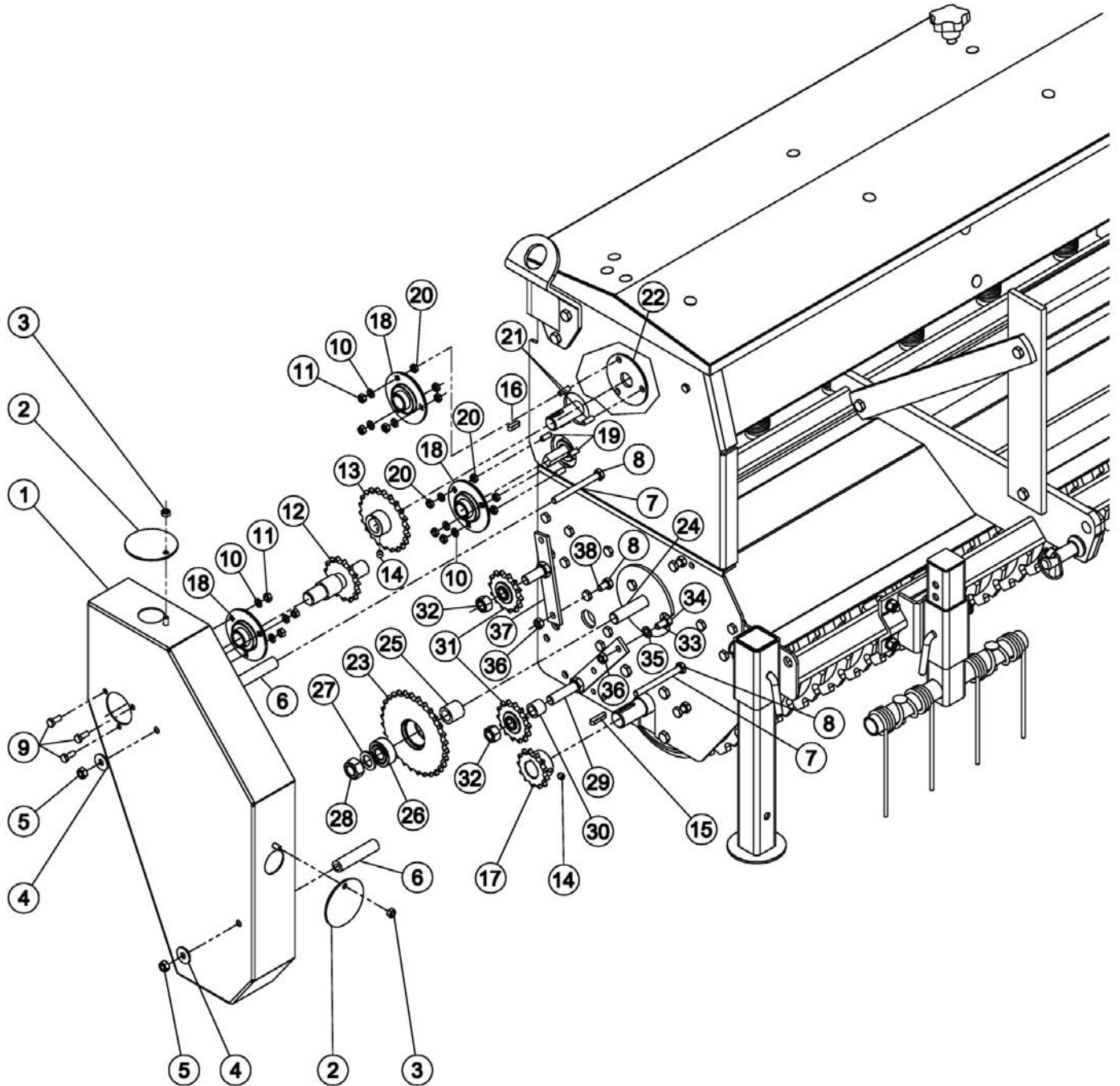



Ref.	Part #	Description	Qty.
1	008-8860	Chain case cover	1
2	008-4596	Access cover	2
3	009-1384	Nut ES M08-1.25 TK Z	2
4	003-0157	Washer fender Ø10 Z	2
5	001-5237	Nut ES M10-1.50 TN Z	2
6	008-8876	Spacer	2
7	000-6943	Bolt HH M10-1.50x120 C8.8 Z F	2
8	009-0150	Nut HH M10-1.50 C6 MD Z	3
9	001-5012	Bolt HH M08-1.25x20 C8.8 Z F	3
10	000-3144	Washer lock Ø08 Z	12
11	000-1806	Nut HH M08-1.25 C6 TK Z	9
12	008-4528	Pinion auger shaft	1
13	008-4527	Sprocket Z22	1
14	008-4376	Set screw M10-1.50x08 C14.9 N	2
15	000-6688	Key 8x7x35	1
16	000-6639	Key 8x7x25	1
17	008-4582	Sprocket Z13	1
18	004-6541	Flange bearing	4
19	009-1446	Bolt HH M08-1.25x25 C8.8 Z F	3
20	004-6545	Nut HH M08-1.25 C6 MD Z	12
21	004-6543	Bolt HH M08-1.25x30 C8.8 Z F	6
22	004-6525	Closing flange	2
23	008-4552	Sprocket assembly	1
24	008-4558	Bolt HH M20-2.50x90 C8.8 Z F	1
25	008-7499	Spacer	1
26	008-4556	Bearing 4204	1
27	004-6555	Washer flat Ø20 W	1
28	000-5507	Nut PT M20-2.50 C6 TK Z	1
29	008-8670	Chain tensioner support, lower	1
30	008-8674	Spacer	1
31	004-6644	Idler sprocket Z14	2
32	000-5581	Nut PT M16-2.00 C6 TK Z	2
33	003-8614	Bolt HH M10-1.50x40 C8.8 Z F	1
34	000-1279	Nut HH M10-1.50 C6 TK Z	1
35	000-2034	Washer flat Ø10 W	1
36	003-0156	Nut PT M10-1.50 C6 TK Z	2
37	008-8680	Chain tensioner support, upper	1
38	009-1281	Bolt HH M10-1.50x35 C8.8 Z F	1

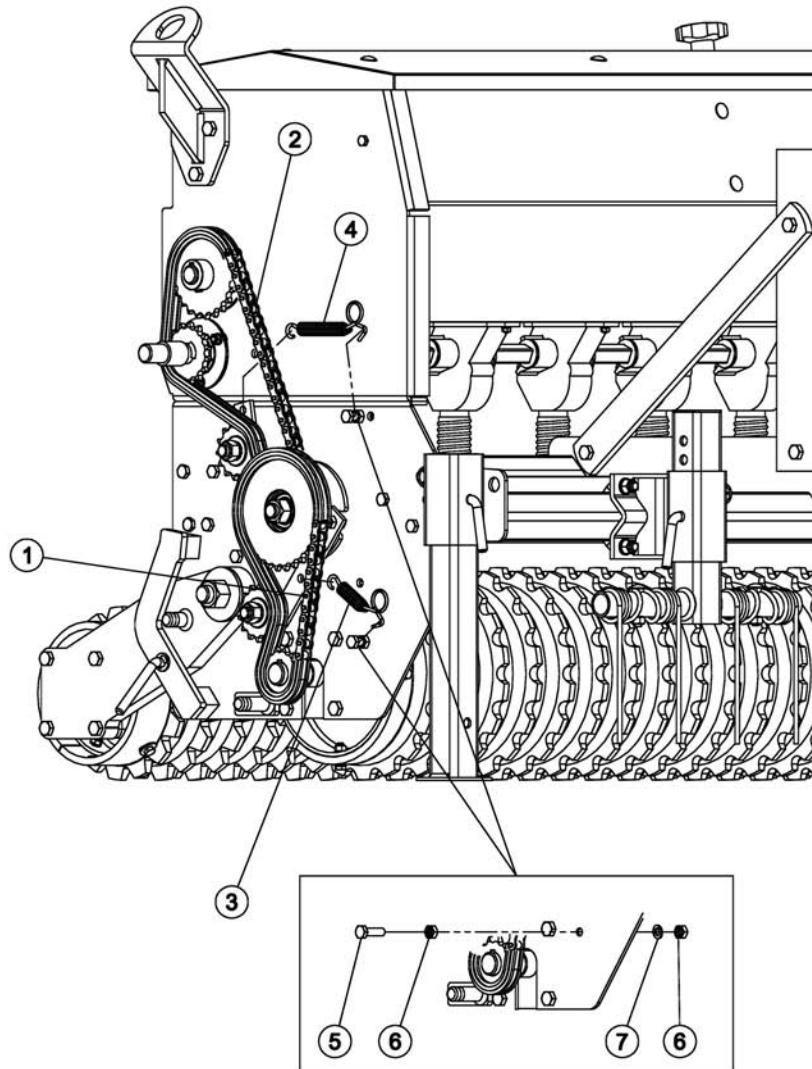

Ref.	Part #	Description	Qty.
1	008-8856	Chain ASA 50x50	1
2	008-8857	Chain ASA 50x66	1
3	000-9726	Spring, lower tensioner	1
4	005-1740	Spring, upper tensioner	1
5	003-8614	Bolt HH M10-1.50x40 C8.8 Z F	2
6	009-0150	Nut HH M10-1.50 C6 MD Z	4
7	000-3144	Washer lock Ø08 Z	2

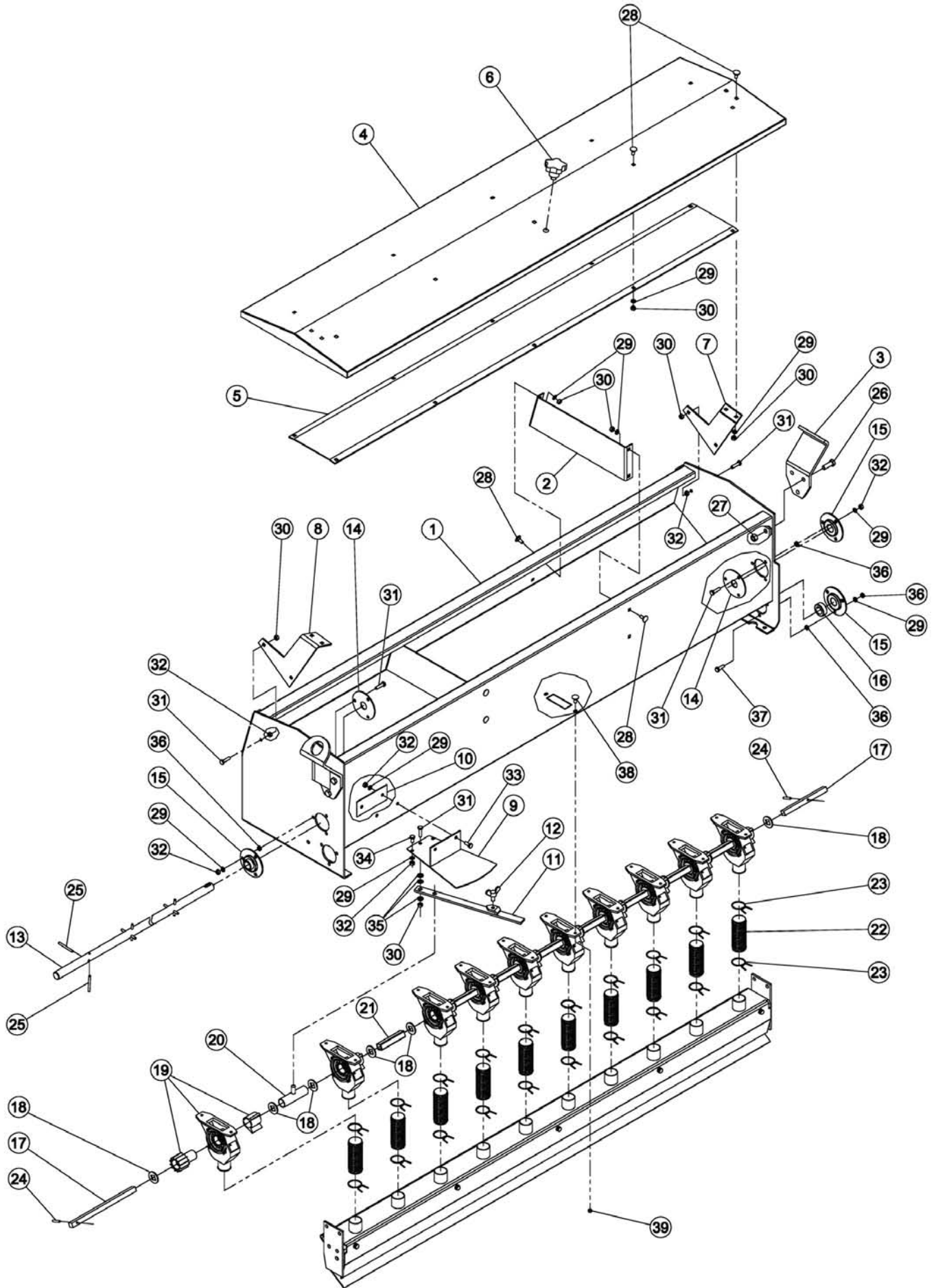

Ref.	Part #	Description	Qty.
1	048-8730	Hopper SRT-074	1
2	008-4287	Hopper support	2
3	008-4284	Lifting hook	2
4	048-8750	Hopper lid SRT-074	1
5	048-8754	Cover support SRT-074	1
6	008-4310	Plastic knob	1
7	018-4302	Hopper hinge, right	1
8	028-4302	Hopper hinge, left	1
9	008-4332	Calibration plate	1
10	004-6472	Plate	1
11	004-6561	Calibration handle	1
12	004-6465	Bolt wing M10-1.50x20 C5 Z	1
13	048-8790	Auger shaft SRT-074	1
14	004-6525	Closing flange	2
15	004-6541	Flange bearing	3
16	008-4375	Collar, shaft	1
17	048-8810	Drive rod SRT-074	1
18	008-4415	Washer flat w/square hole	20
19	004-6531	Seed cup assembly	10
20	004-8331	Spacer	1
21	004-8391	Spacer	8
22	008-8825	Fertilizer tube L. 11 cm.	10
23	004-6533	Wire ring clamp	20
24	000-6605	Roll pin Ø6x32	2
25	004-6521	Roll pin Ø6x60	20
26	000-7255	Bolt HH M12-1.75x35 C8.8 Z F	6
27	003-0064	Nut PT M12-1.75 C6 TK Z	6
28	008-4289	Bolt CR M08-1.25x20 C4.6 Z	22
29	000-3144	Washer lock Ø08 Z	35
30	009-1384	Nut ES M08-1.25 TK Z	25
31	004-6543	Bolt HH M08-1.25x30 C8.8 Z F	9
32	000-1806	Nut HH M08-1.25 C6 TK Z	12
33	001-5012	Bolt HH M08-1.25x20 C8.8 Z F	2
34	004-6454	Bolt HH M08-1.25x16 C8.8 Z F	2
35	000-2034	Washer flat Ø10 W	3
36	004-6545	Nut HH M08-1.25 C6 MD Z	12
37	009-1446	Bolt HH M08-1.25x25 C8.8 Z F	3
38	004-6535	Bolt CR M06-1.00x16 C4.6 Z	20
39	200-3001	Nut kep M06-1.00 Z	20

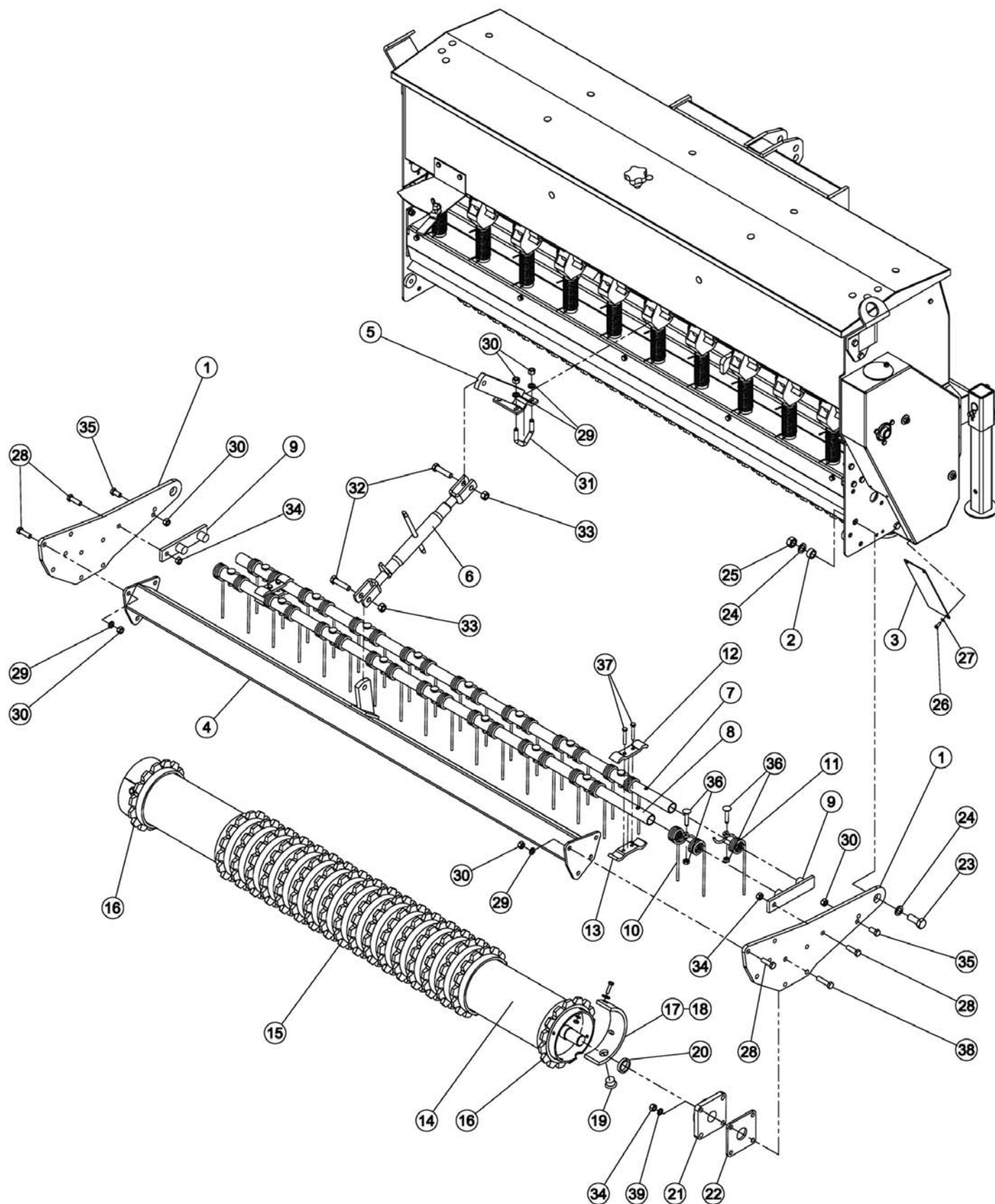

Ref.	Part #	Description	Qty.
1	008-8910	Roller arm	2
2	004-8470	Spacer, roller arm	2
3	008-8870	Protection plate	1
4	038-4462	Rear crossbar SRT-074	1
5	008-4432	Turnbuckle hitch	1
6	003-8773	Turnbuckle	1
7	038-4505	Tickler bar, front SRT-074	1
8	038-4501	Tickler bar, rear SRT-074	1
9	004-6347	Pivot assembly	2
10	004-6358	Tickler tooth spring	17
11	004-6360	Tickler tooth ½ spring	1
12	004-6351	Locking plate	2
13	014-6351	Locking plate	2
14	048-8640	Rear roller SRT-074	1
15	014-6322	Corrugated roller ring, nylon-fiberglass	27
	008-8645	Corrugated roller ring, cast iron (option)	27
16	008-8649	Corrugated roller semi-ring, nylon-fiberglass	2
	008-8646	Corrugated roller semi-ring, cast iron (option)	2
17	008-8650	End ring with hole	2
18	008-8651	End ring without hole	2
19	008-8658	Plastic cap	2
20	008-8588	Spacer	2
21	004-6331	Support UCF 207 TF	2
22	008-8625	Spacer plate	2
23	006-4377	Bolt HH M18-2.50x45 C8.8 Z F	2
24	005-0049	Washer flat Ø18 Y	4
25	001-7506	Nut PT M18-2.50 C6 TK Z	2
26	003-6319	Bolt HH M06-1.00x16 C8.8 Z F	3
27	004-6536	Washer lock Ø6 Z	3
28	002-3265	Bolt HH M12-1.75x40 C8.8 Z F	10
29	000-1077	Washer lock Ø12 Z	12
30	000-3038	Nut HH M12-1.75 C6 TK Z	14
31	001-1253	Bolt "V" M12-1.75 Z	2
32	003-2682	Bolt HH M14-2.00x55 C8.8 Z P	2
33	003-0358	Nut PT M14-2.00 C6 TK Z	2
34	003-0064	Nut PT M12-1.75 C6 TK Z	10
35	000-3037	Bolt HH M12-1.75x25 C8.8 Z F	2
36	004-6362	Bolt CR M10-1.50x50 C4.6 Z	18
37	000-8037	Bolt HH M08-1.25x50 C8.8 Z F	4
38	000-6963	Bolt HH M12-1.75x55 C8.8 Z P	8
39	000-2265	Washer flat Ø12 W	8

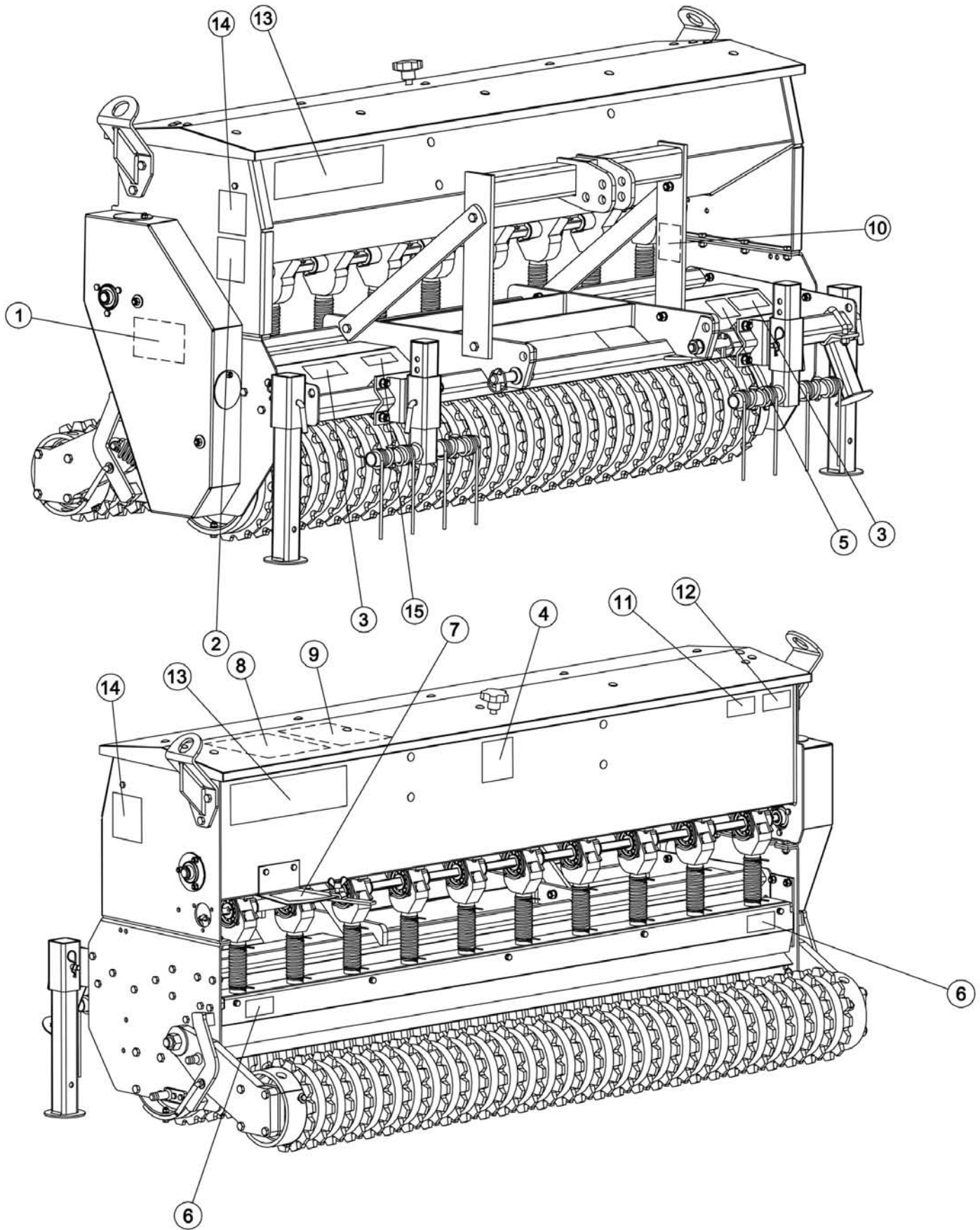



Ref.	Part #	Description	Qty.
1	950-213B	Decal "DANGER - Replace shield"	1
2	950-486B	Decal "DANGER - Moving parts hazard"	1
3	950-342B	Decal "DANGER - Crushing hazard"	2
4	950-343B	Decal "WARNING - Falling hazard"	1
5	950-417B	Decal "CAUTION - Read operator's manual"	1
6	950-366B	Decal, red reflective	2
7	937-0116	Decal "Seed calibration scale"	1
8	950-294B	Decal "Table 1 seed distribution"	1
9	950-293B	Decal "Table 2 seed distribution"	1
10	950-940B	Decal "Quick hitch compatible"	1
11	950-472B	Decal "SRT"	1
12	950-281B	Decal "074"	1
13	950-107B	Decal "BEFCO"	2
14	950-104B	Decal "B" logo	2
15	950-381B	Decal "BEFCO INC." address	1
	971-395B	Operator's & Parts Manual SRT-074	1



## **Use only original spare parts**

*All rights reserved. It is unlawful to copy, reprint or use any of the information or details in this manual without the expressed written permission of the Company. Technical information provided in this manual is approximate, the Company reserves the right to modify or improve the models shown for technical or commercial purposes. Pictures in this manual do not necessarily show the machine as delivered.*

---

**BEFCO**<sup>®</sup>

P.O. Box 6036  
Rocky Mount, NC 27802-6036  
Tel.: 252.977.9920 - Fax: 252.977.9718  
[www.befco.com](http://www.befco.com)

